

QHD

# 潜水混流泵



## 产品特点

- 高效节能
- 性能稳定
- 工艺先进
- 安全可靠
- 自动监测

智慧流动  
共生美好

FLOW  
TOWARDS  
THE FUTURE

利欧集团泵业有限公司  
LEO GROUP PUMP CO., LTD.



利欧公众号



利欧视频号



利欧抖音号



产品电子书

总部地址 | 浙江省杭州市钱塘区23号大街505号

TEL | 400-711-3699

基地地址 | 浙江省温岭市东部产业集聚区第三街1号  
湖南省湘潭市雨湖区九华经开区九华大道9号  
辽宁省大连市旅顺口区长城街道畅顺路19号

WEB | www.leopump.com

E-MAIL | service@leopump.com

## 应用场景

主要应用于水利工程、农田灌溉、工业用水、城市给排水及调水工程

# 从中国的利欧到世界的LEO

创立于 **1995** 年，是全球领先的智慧流体合作伙伴  
品牌足迹已遍布 **160+** 国家及地区，服务全球 **5亿** 用户

利欧泵业致力于把智慧用水体验汇入每个行业、每个群体、每个家庭，帮助世界各地的人们随时随地享受高品质用水生活。“智慧流动，共生美好”，利欧泵业聚焦实体经济，布局建筑、市政及水务、水利、电力、石化、家用、园林及OEM业务八大领域，以科技创新为全球用户定制个性化的泵与系统解决方案，助力政府和企业客户实现绿色转型，推动经济高质量增长和社会可持续发展。

## 核心荣誉资质展示



## 利欧泵业

## 全球拥有五大制造基地



从中国的利欧到世界的LEO，利欧用最值得信赖的产品与服务，持续造福于人，择善而行已实现研发、生产、营销、售后一体化产业之路。

QHD  
潜水混流泵

-  高效节能
-  高可靠性
-  工艺先进
-  维护方便
-  自动监测

功率  
**37-1600kW**

型号规格  
**350~1600mm**

流量  
**700-36000m<sup>3</sup>/h**

扬程  
**8-50m**



产品概述

QHD 系列由利欧湖南工业泵基地研发，是在总结了大量实践数据与工程经验中设计的一款新型高效、可靠的潜水混流泵产品。与传统的潜水轴、混流泵相比，该系列采用了我司研发的新一代水力模型与专利密封结构，具有效率高、汽蚀好、流道合理、结构可靠等特点。

本系列产品的设计、制造和质量符合 GB/T13008《混流泵、轴流泵技术条件》、JB/T 11916《大中型潜水电泵》标准。

应用领域

本系列产品主要用于供输介质温度不超过 43°C 的清水或物理化学性质近似水的其他液体，广泛应用于大型水利工程、农田灌溉、输送工业用水、热电站输送循环水、船坞升降水位、城市给排水及调水工程。

选型说明

水泵扬程 H：即总扬程，是净扬程与进出水流道的水力损失之和；在选型时需设计扬程、最高扬程及最低扬程数据，是选型必不可少的参数

水泵流量 Q：水泵在单位时间内输送出去的液体量，本样本的常用单位是 m<sup>3</sup>/s、L/s，是选型必不可少的参数。

转速 n：叶轮单位时间的转速，单位是 r/min。

轴功率 P：水泵输入功率

配套功率 Pe：即电机功率，通常按 1.15 倍的轴功率取值。

工作条件

输送介质：清水、雨水、江河水、污水、废水及物理化学性质近似水的其他液体；

额定电压：380V，也可采用 660V、3KV、6 KV、10 KV 等；

频率：50Hz 三相交流电源，工频或变频；

介质温度：≤ 43°C；

运行方式：软启动或变频；

旋转方向：从电机看，泵顺时针方向旋转。

型号含义

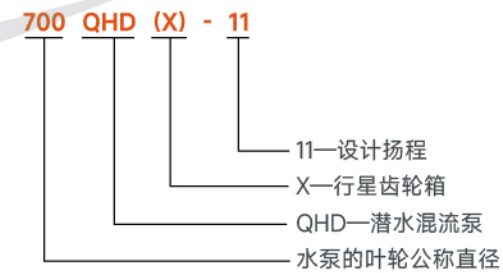

# QHD Series

Mixed-flow pump



Energy-efficient



High reliability



Advanced technology



Maintenance friendly



Automatic monitoring

Power  
**37-1600kW**

Model specification  
**350~1600mm**

Flow  
**700-36000m<sup>3</sup>/h**

Head  
**8-50m**



## General information

QHD series submersible axial flow pump is a new generation products independently developed by LEO company. It is not only simple in structure, easy to disassemble and assemble, but also has excellent performance as an alternative to traditional axial flow pumps.

This QHD series products has a wide spectrum, good hydraulic performance and novel structure. It is characterized by high efficiency, good cavitation performance, easy installation and maintenance. At the same time, combined with the latest remote control technology, the intelligent water pump system independently developed can be configured, with automatic monitoring function.

The design, manufacture, and quality of this series product meets the standard of GB/T13008 《Technical conditions for mixed-flow pump and axial-flow pump》、JB/T 11916 《Large and medium-sized submersible motor-pumps》

## Selection instruction

**Pump Head H:** The total head is the sum of net head and hydraulic loss of the inlet and outlet flow channels; the design head, the highest head and the lowest head data are required during pump selection, which is an essential parameter.

**Pump flow Q:** The amount of liquid delivered by the pump in a unit of time which is a key parameter for pump selection. The common units in this catalogue are m<sup>3</sup>/s and L/s.

**Speed n:** The speed of the impeller per unit time. The unit is r/min.

**Shaft power P:** Input power of water pump.

**Power Pe:** Motor power, it is usually 1.2 times of the shaft power.

## Application Area

This series of products can be used for clear water or other liquids with physical and chemical properties close to water. The temperature of conveying medium is no more than 50°C. They are widely used in large-scale water conservancy projects, farmland irrigation, industrial water conveying, water circulating in thermal power station, shipyard lifting, urban water supply and drainage, water diversion projects, etc.

## Working condition

**The medium:** Clear water, rain water, river water, sewage, waste water, liquids with physicochemical properties similar as water

**Rated voltage:** 380V or 660V、3KV、6KV、10kV, etc

**Frequency:** 50Hz three-phase AC power, Power frequency or variable frequency

**Medium temperature:** ≤ 43°C

**Start mode:** Soft start or variable frequency start

**Direction of rotation:** from the drive end, the pump is rotated in clockwise

## Model definition

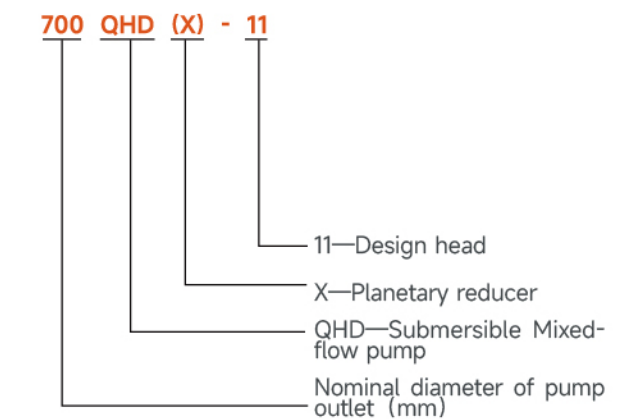

产品特点 /Product Features



高效节能

水力模型采用三元流理论设计及 CFD 仿真模拟计算，性能达到理论最佳。水力部件均采用金属模具，精密铸造，叶片及导叶的模具数控加工，实体流道完全还原设计图纸，保证水泵效率，且高效区宽。

Efficient and energy-saving

The hydraulic model adopts three-dimensional flow design and CFD simulation calculation, achieving the theoretical best performance. The hydraulic components are all made of metal molds, precision casting, and CNC machining of blade and guide vane molds. The solid flow channel is fully restored to the design drawings, ensuring the efficiency of the water pump and a wide efficient area.



高可靠性

进水流道设计合理，进水均无旋涡，运行平稳。泵轴绝对同心度及转子部件极好的静平衡，保证泵在高速运转时振动小，噪音低。

High reliability

The inlet channel design is reasonable, and there are no vortices in the inlet, ensuring smooth operation. The absolute concentricity of the pump shaft and excellent static balance of the rotor components ensure minimal vibration and low noise during high-speed operation of the pump.



工艺先进

所有零部件采用金属模具，精密铸造，零件质量可靠。

Advanced technology

All components are made of metal molds, precision casting, and the quality of the parts is reliable.



低维护

结构合理，装拆方便，维护简便。

Low maintenance

Reasonable structure, easy installation and disassembly, and easy maintenance.

产品特点 /Product Features



自动监测

可配置自主研发的智慧水泵系统，具有自动监测功能。

Automatic monitoring

It can be configured with a self-developed smart water pump system with automatic monitoring function.



库存管理

合理的库存管理，交货周期短，供货快速。

Inventory management

Reasonable inventory management, short delivery cycle, and fast supply.

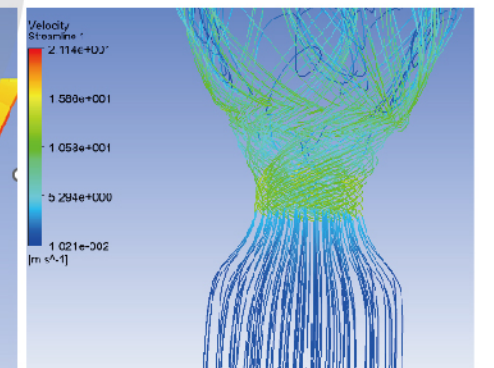
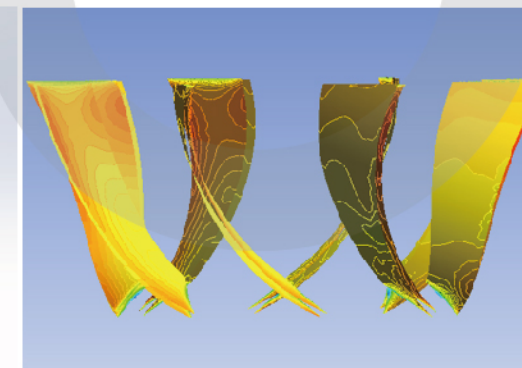
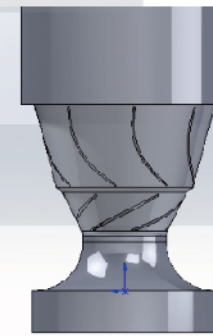

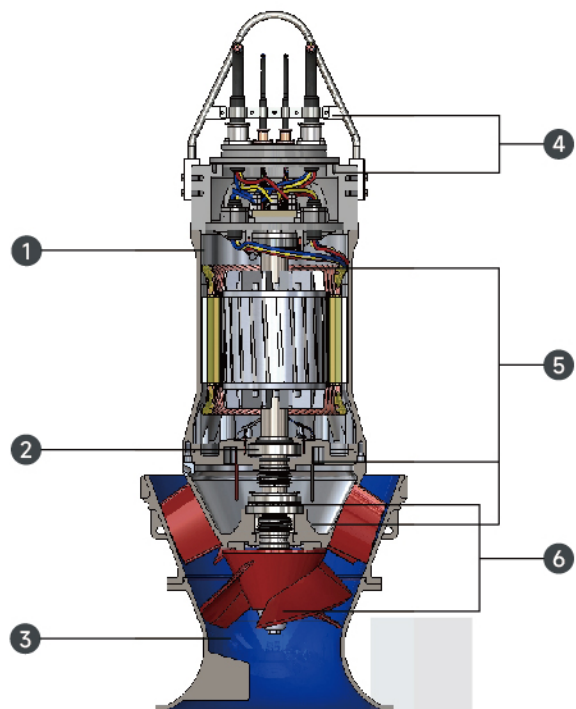

**结构特点**

1	专用潜水电机 全系列 F 级绝缘，防护等级为 IP68；低能耗，低温升，高稳定性。比普通电机增加 60 度的耐热度，寿命延长，接线腔与电机定子密封隔开，双保险。电机轴承采用副油箱结构增加轴承使用寿命。	2	电机保护系统 电机内置了多项预警传感器，包括有接线室、电机腔和油室腔内渗漏、轴承和电机线圈温升保护。电机设置漏水监测、油室设有油混水探头等。全面监测电机运行情况。
3	水力部件 采用三元流理论设计，CFD 计算模拟，无堵塞、无过载设计，效率高，高效区宽、低能耗，采用新型无堵塞叶轮。泵体流道宽敞，固形物容易通过，纤维不易缠绕。叶轮经严格平衡，从而使振动减至最低，并最大限度地延长轴承和机械密封的寿命。	4	电缆防松密封系统 电缆出线采用了特别结构，排除了因人为拉扯、电缆外套破碎、电缆老化等偶然因素导致电机的漏水、漏电、短路、定子线圈烧毁，有效地降低了整机上部进水出现故障的概率。
5	轴承部件 轴承为 1 个推力调心滚子轴承 + 1 个圆柱滚子轴承 + 1 个深沟球轴承，承受水泵端轴向力和径向力，电机轴承采用脂润滑，水泵轴承采用稀油润滑，该结构轴承运行稳定，电机轴不会出现前后窜动的现象，因此水泵运行中轴承发热量小，无噪音。	6	密封系统 产品应用专利结构，双密封室结构，泵端采用组合双重集装式机械式密封，增加了缓冲室。提高了密封的可靠性，完全保证了产品的稳定运行。机械密封采用集成安装方式。

**Structural features**

1	Special Submersible Motor The whole series of motors are F-class insulation, IP68 protection level, low energy consumption, low temperature rise, and high stability. Compared with ordinary motors, it is 60 degrees Celsius increased in heat resistance, extend life time. The wiring chamber is sealed and separated from stator and rotor of the motor as double insurance. The motor bearing adopts auxiliary oil	2	Protection System for Electrical Motor Pump There are a number of built-in warning sensors in motor including the leakage sensors in wiring chamber, motor cavity and the oil-water mixture probe in oil chamber, etc. The temperature rise of the bearing and the motor coil is also monitored. The operation of motor is under a comprehensive
3	Hydrodynamic parts The product adopt three-dimensional flow theory design, CFD calculation simulation, non-blocking, non-overload design. It is high efficiency, wide efficient range, low energy consumption. Solids are easy to pass, and the fibers are not easy to entangle because of wide passage of pump body and double-flow channel and non-blocking impeller. The impeller is strictly balanced to minimize vibration and maximize the life of bearings and mechanical seals.	4	Cable Locking and Sealing System The outlet of cable is special structure, which can eliminate water leakage, electricity leakage, short circuit, and stator coil burnout caused by accidental factors such as artificial pulling, broken cable jacket, and cable aging. It reduces the probability of failure caused by water in the upper part of the whole machine effectively.
5	Sealing System The bearing consists of one thrust self-aligning roller bearing, one cylindrical roller bearing, and one deep groove ball bearing, which bear the axial and radial forces at the water pump end. The motor bearing is lubricated with grease, while the water pump bearing is lubricated with thin oil. This structure ensures stable operation of the bearing and prevents forward and backward movement of the motor shaft. Therefore, the bearing generates less heat and produces no noise during the operation of the water pump.	6	Sealing System The product features a patented structure and a dual sealed chamber design. The pump end adopts a combined dual container mechanical seal, which adds a buffer chamber. Improved the reliability of the seal and fully ensured the stable operation of the product. The mechanical seal adopts an integrated installation method.

**结构图 / Structure drawing**

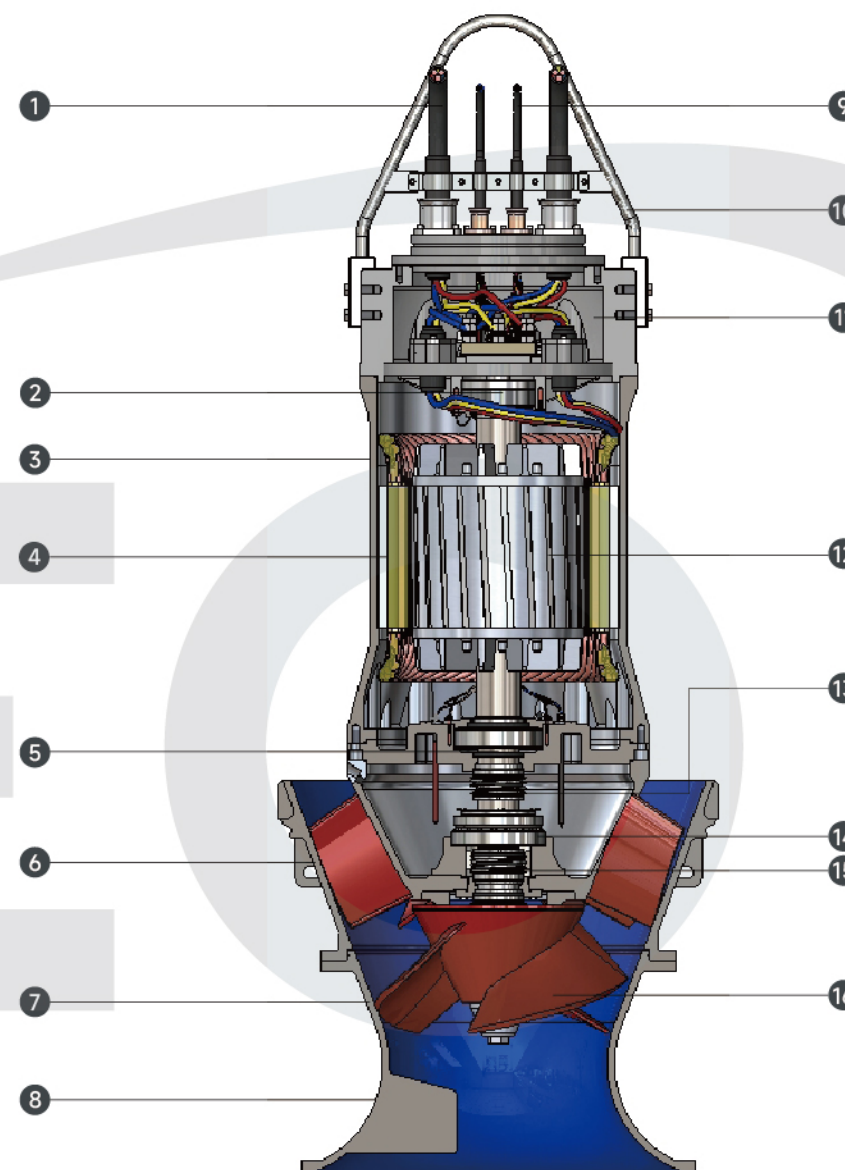

1	动力电缆	5	下轴承	9	控制电缆	13	电机侧机械密封
2	上轴承	6	导叶体	10	吊耳	14	推力轴承
3	机壳	7	叶轮室	11	接线腔	15	水泵侧机械密封
4	定子	8	吸入喇叭口	12	转子	16	叶轮部件

1	Power cable	5	Lower bearing	9	Control cable	13	Mechanical seal on motor side
2	Upper bearing	6	Guide blade body	10	Lifting lug	14	Thrust bearing
3	Case	7	Impeller chamber	11	Wiring cavity	15	Mechanical seal on pump side
4	Stator of motor	8	Suction cone	12	Motor rotor	16	Impeller parts

**水泵保护系统 / Pump protection system**

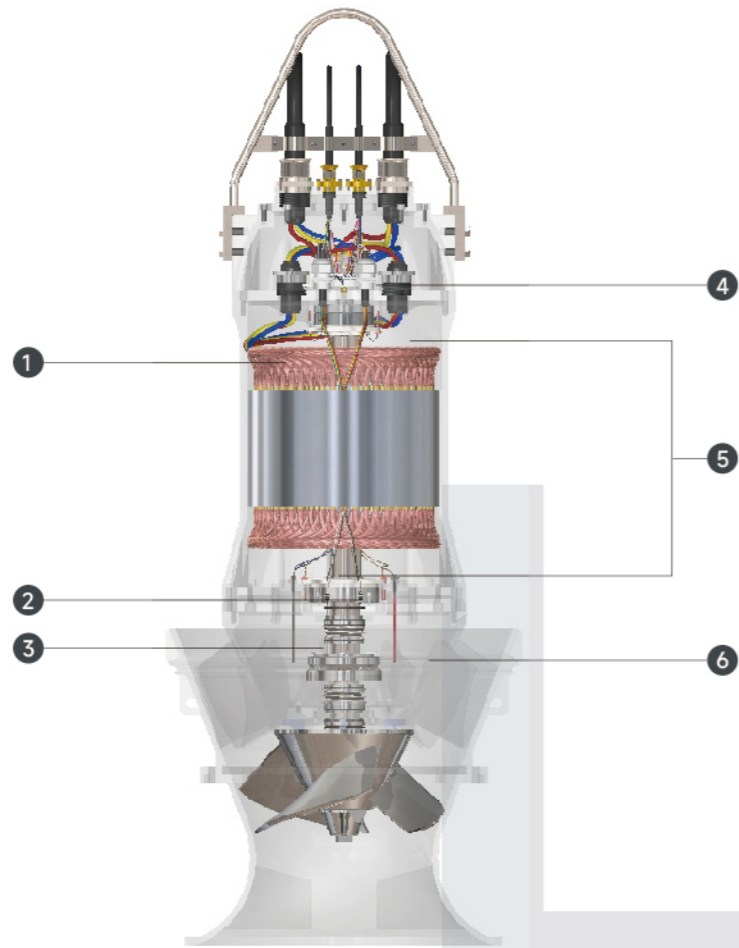

以上所有测点均一用一备  
All the sensors are one duty and one standby

1	电机温升保护 在定子绕组 A、B、C 三相分别嵌设二只温度传感器，作为超温时停机的检测报警元件。	4	接线室泄漏保护 在电机接线盒内设置渗漏传感器，遇水即报警，提示维修。
2	电机腔泄漏保护 在电机腔内设置漏水传感器，监测泄漏，遇水即报警，提示维修，以防止水或油进入电机腔。	5	电机轴承温升保护 在电机上下轴承处分别嵌设二只温度传感器，来监测轴承温度。
3	油室湿度报警 在油室内，设置湿度传感器，监测油室泄漏。	6	油室温升保护 在油室内，设置温度传感器，监测油室温度。

1	Motor Temperature Rise Protection Two temperature sensors are embedded in the three phases of the stator windings A, B, and C respectively, as detection and alarm components for shutdown during over temperature.	4	Wiring Chamber Leakage Protection A leakage sensor is installed in the motor junction box, and an alarm will be issued to maintain when it is wet with water.
2	Motor Cavity Leakage Protection A water sensor is installed in the inner cavity of the motor to monitor leakage, and an alarm will be issued when it goes wet to remind maintenance in case water or oil from entering the inner cavity of the motor.	5	Bearing Temperature Rise Protection Two temperature sensor are installed in the bearing seat to monitor the bearing temperature.
3	Oil Chamber Humidity Alarm In the oil chamber, set a humidity sensor to monitor the oil chamber for leakage.	6	Oil Chamber Temperature Rise Protection A temperature sensor is set to monitor the temperature in oil chamber.

**水泵保护系统 / Pump protection system**

水泵保护系统中的各种保护装置、泵外侧液位控制器需与潜水泵专用电控柜配套使用。所以，潜水泵的电控柜是比较特殊的，专业性很强。我司的潜水泵专用电控柜与泵的保护装置是配套的，对水泵进行自动保护功能（短路、缺相、断相、过载、除湿等保护），实现泵的无人看管、自动运行及信号输出。控制柜有手动和自动两种启动方式。

Here are various devices in the water pump protection system. The liquid level controller outside the pump need to be integrated with Electric control cabinet dedicated to the submersible sewage pump. Therefore, the electric control cabinet of the submersible sewage pump is relatively special and highly specialized. The special electric control cabinet for LEO submersible sewage pump is used to supply protection for pump (short circuit, phase loss, phase failure, overload, de-humification etc. , and can carry out unattended use, automatic operation and signal output of the pump. There are two start-up methods of the electric control cabinet: manual and automatic.



综合保护器  
Integrated protector



温度传感器  
Temperature Sensor



漏水探头  
Water Leakage Probe

**水泵控制系统（选配） / Water pump control system (optional)**

每套水泵系统可配套中间端子箱一只，用于水泵与控制柜的中间连接。

液位开关用于泵站的控制，灵活方便，信号可靠，能根据水位的变化对水泵进行自动控制。

Each set of water pump system can be equipped with a middle terminal box, which is used for connection between water pump and control cabinet.

The liquid level switch is used for the control of the pumping station, which is flexible and convenient with reliable signals. It can be used to control the water pump according to the change of the water level automatically.



电控柜  
Electric control cabinet



端子箱  
Terminal box



液位开关  
Liquid level switch

泵站井筒示意图 / Schematic diagram of pumping station wellbore

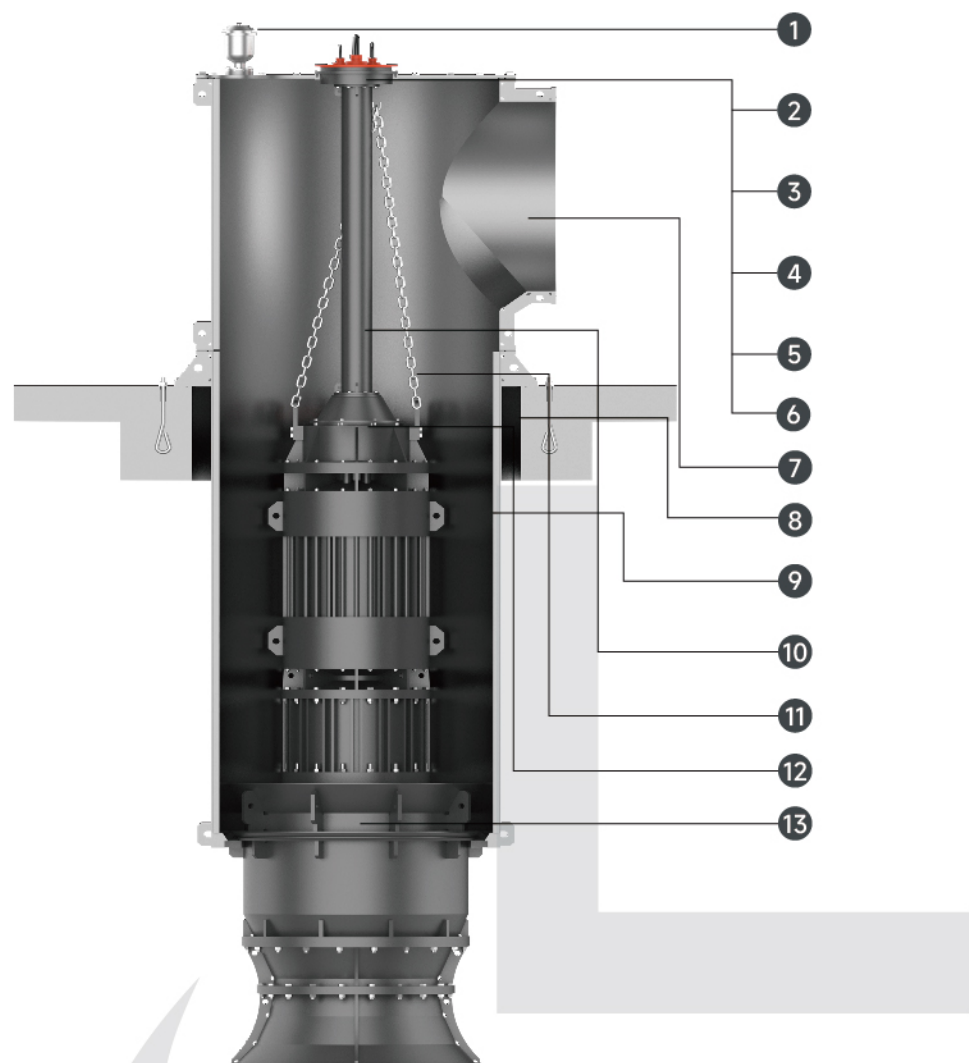

1	排气阀	8	预埋板	1	Vent valy	8	Pre-embedded plate
2	护管盖板	9	井筒座	2	Protecting tube plate	9	Shaft seat
3	电缆密封装置	10	电缆护管	3	Cable seal holder	10	Cable protection pipe
4	橡胶密封圈	11	吊链	4	Rubber seal	11	Lifting chain
5	护管压板	12	导流罩 + 防抬底座	5	Pressing plate	12	Fairing+Prevent lifting the base
6	护管密封座	13	潜水混流泵	6	Protective tube seal seat	13	Submersible axial-flow pump
7	出水弯管			7	The water pipe		

落地式安装示意图 / Installation Instruction

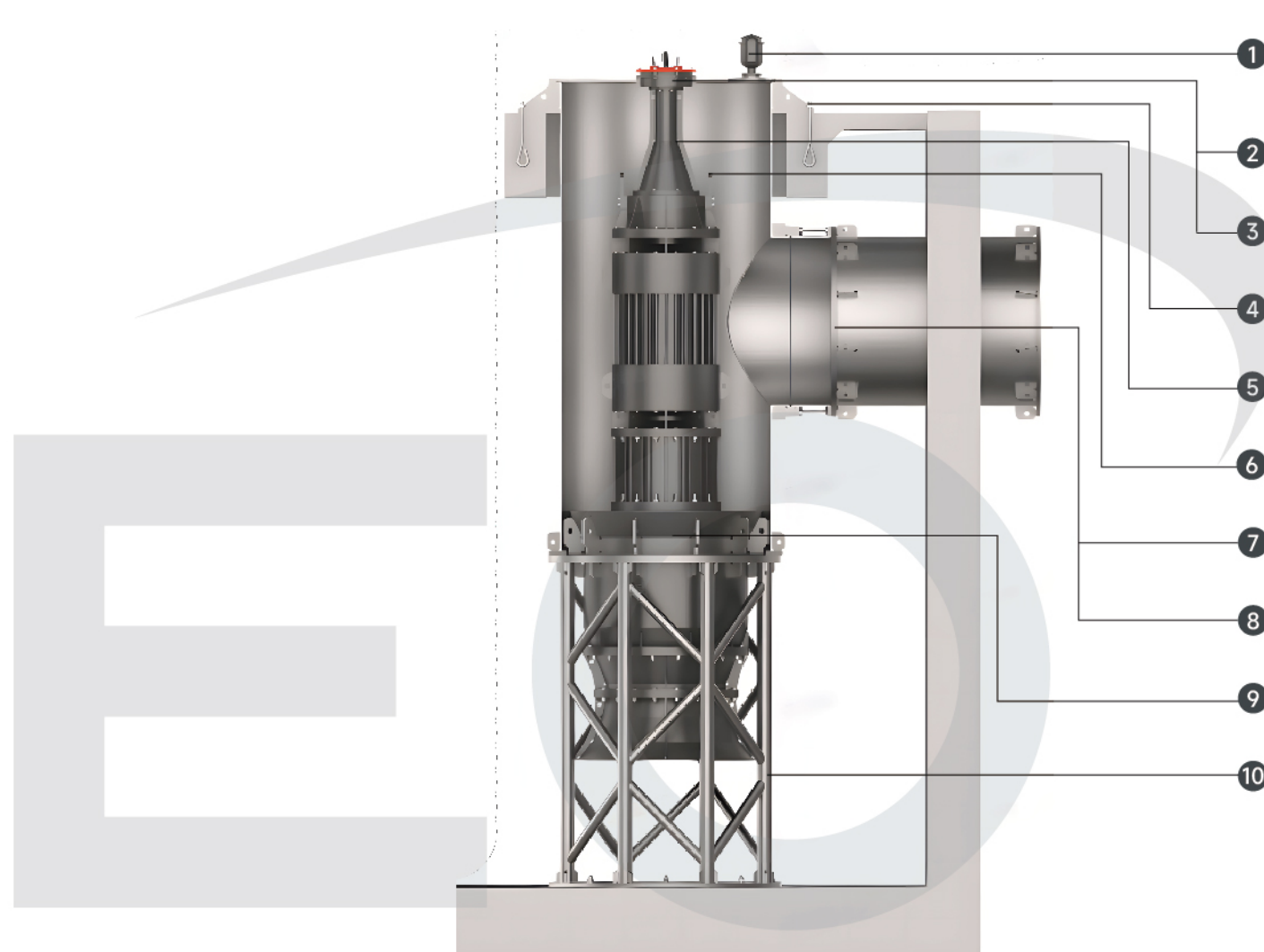

1	排气阀	6	吊耳	1	exhaust valve	6	Lifting lug
2	电缆密封部件	7	出水井筒	2	Cable seal assembly	7	Effluent shaft
3	护管密封部件	8	穿墙管	3	Protective tube sealing component	8	Through-wall pipe
4	预埋底座	9	潜水混流泵	4	Embedded base	9	Submersible mixed flow pump
5	防抬装置	10	支撑底座	5	Anti-platform device	10	Supporting base

标准配置零件材质表 /Material table of standard configuration

分项 Sub item	零件名称 Part name	标配 1 (清水) Standard 1(water)	标配 2 (海水) Standard 2(sewage)
电机部分 Motor part	电机壳体 Case	HT250 (A4835)	ZG03Cr22Ni6Mo3N (22Cr-5Ni-Mo-N)
	接线盒 Terminal box	HT250 (A4835)	ZG03Cr22Ni6Mo3N (22Cr-5Ni-Mo-N)
	轴 Axis	2Cr13 (A276-420)	022Cr23Ni5Mo3N (22Cr-5Ni-Mo-N)
	定子 Stator	硅钢片 + 铜 Silicon steel sheet + copper	
	铁芯 Core	铸铝 Cast aluminum	
	动力电缆 Power cable	潜水泵专用电缆 (YCW) Special cable for submersible pump	潜水泵专用电缆 (JSH) Special cable for submersible pump
控制线电缆 Control cable			
水泵部分 Pump part	导叶体 Diffuser	HT250 (A4835)	ZG03Cr22Ni6Mo3N (22Cr-5Ni-Mo-N)
	叶轮部件 Impeller component	ZG07Cr19Ni10(CF8)	ZG03Cr22Ni6Mo3N (22Cr-5Ni-Mo-N)
	叶轮室 Impeller chamber	HT250 (A4835)	ZG03Cr22Ni6Mo3N (22Cr-5Ni-Mo-N)
	水泵壳体 Case	HT250 (A4835)	ZG03Cr22Ni6Mo3N (22Cr-5Ni-Mo-N)
配套部分 Matching Kit part	机械密封 mechanical seal	碳化硅 - 钨 SiC-W	碳化硅 - 钨 SiC-W 022Cr23Ni5Mo3N (22Cr-5Ni-Mo-N)
		国产品牌 / 博格曼 Domestic brand / Bergman	
	轴承 Bearing	国产轴承 /SKF 轴承 Domestic bearing/SKF Bearing	
	井筒部件 mineshaft	Q235-B(A36)	022Cr23Ni5Mo3N (22Cr-5Ni-Mo-N)
连接件 Connector	A2-70	022Cr23Ni5Mo3N (22Cr-5Ni-Mo-N)	

备注：以上标准配置以外的材质，可根据客户需要或输送介质的特性选定。

Note:Materials other than the above standard configuration can be selected according to customer's needs or the characteristics of the conveying media.

产品型谱图 /QHD Comprehensive performance curve

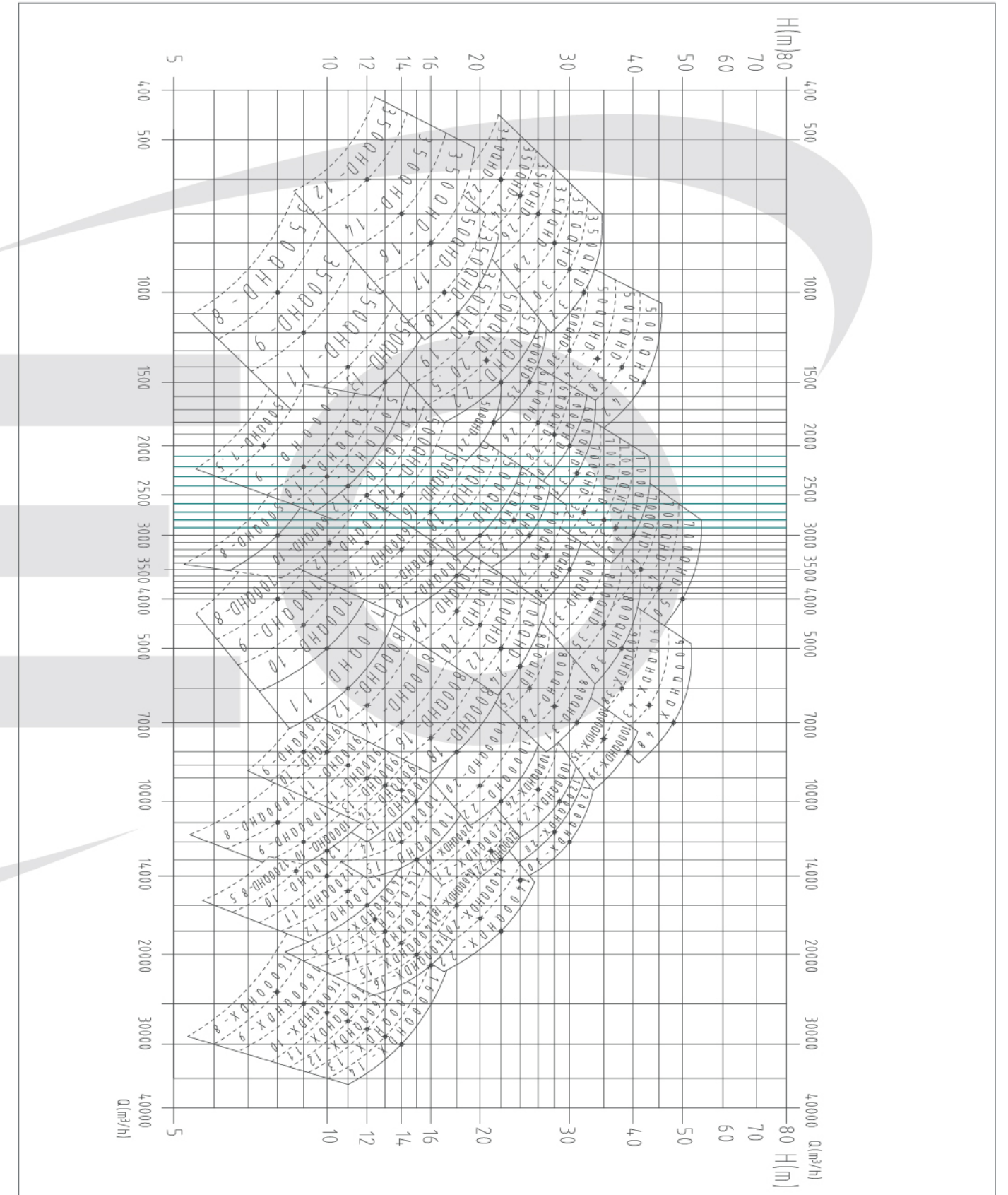

性能参数表 /Performance Parameters Table

序号 NO.	型号 Type	流量 Q Capacity (m³/h)	流量 Q Capacity (m³/s)	扬程 H Head (m)	转速 n Speed (r/min)	轴功率 P shaft Power (kW)	电机功率 P(kW) Motor Power	效率 η Eff. (%)	配套井筒 Wellbore diameter (mm)	泵重 Weight (kg)
1	350QHD-8	700	0.19	10.2	1450	30	37	64	DN800	790
		1000	0.28	8		28		79		
		1200	0.33	6.1		25		81		
2	350QHD-9	840	0.23	11.5	1450	40	45	65	DN800	810
		1200	0.33	9		37		80		
		1440	0.40	7.2		34		82		
3	350QHD-11	980	0.27	14	1450	57	65	66	DN800	900
		1400	0.39	11		52		81		
		1680	0.47	8.4		46		83		
4	350QHD-13	1050	0.29	16.5	1450	70	75	67	DN800	910
		1500	0.42	13		66		81		
		1800	0.50	10		59		83		
5	350QHD-12	420	0.12	15	1450	25	37	69	DN800	690
		600	0.17	12		25		77		
		720	0.20	8		21		74		
6	350QHD-14	490	0.14	17	1450	32	45	70	DN800	710
		700	0.19	14		34		78		
		840	0.23	10		31		75		
7	350QHD-16	560	0.16	19	1450	41	55	70	DN800	750
		800	0.22	16		45		78		
		960	0.27	12.2		43		75		
8	350QHD-17	700	0.19	21	1450	55	65	71	DN800	800
		1000	0.28	17		59		79		
		1200	0.33	13		56		76		
9	350QHD-18	770	0.21	22	1450	63	75	72	DN800	810
		1100	0.31	18		67		80		
		1320	0.37	14		65		77		
10	350QHD-19	840	0.23	23	1450	73	90	72	DN800	870
		1200	0.33	19		78		80		
		1440	0.40	14.5		75		76		
11	350QHD-22	420	0.12	23.7	1450	41	55	66	DN800	800
		600	0.17	22		49		74		
		720	0.20	18		50		71		
12	350QHD-24	455	0.13	26	1450	49	65	66	DN800	850
		650	0.18	24		57		74		
		780	0.22	20.5		61		71		

性能参数表 /Performance Parameters Table

序号 NO.	型号 Type	流量 Q Capacity (m³/h)	流量 Q Capacity (m³/s)	扬程 H Head (m)	转速 n Speed (r/min)	轴功率 P shaft Power (kW)	电机功率 P(kW) Motor Power	效率 η Eff. (%)	配套井筒 Wellbore diameter (mm)	泵重 Weight (kg)
13	350QHD-26	490	0.14	28.2	1450	57	75	66	DN800	860
		700	0.19	26		67		74		
		840	0.23	22.2		72		71		
14	350QHD-28	560	0.16	31	1450	72	90	66	DN800	920
		800	0.22	28		82		74		
		960	0.27	24		88		71		
15	350QHD-30	630	0.18	32.4	1450	84	110	66	DN800	400
		900	0.25	30		99		74		
		1080	0.30	25.7		107		71		
16	350QHD-32	700	0.19	34.7	1450	100	132	66	DN800	1250
		1000	0.28	32		118		74		
		1200	0.33	27.5		127		71		
17	500QHD-8	2100	0.58	10.6	980	85	90	71	DN850	1330
		3000	0.83	8		80		82		
		3600	1.00	6.8		84		79		
18	500QHD-7.5	1400	0.39	10.5	980	61	65	66	DN850	770
		2000	0.56	7.5		50		81		
		2400	0.67	6.3		50		82		
19	500QHD-9	1540	0.43	11.5	980	73	75	66	DN850	780
		2200	0.61	9		67		81		
		2640	0.73	6.8		60		82		
20	500QHD-10	1610	0.45	13	980	85	90	67	DN850	810
		2300	0.64	10		77		81.8		
		2760	0.77	7.6		69		83		
21	500QHD-11	1680	0.47	14	980	94	110	68	DN850	1040
		2400	0.67	11		88		82		
		2880	0.80	8.5		80		83.5		
22	500QHD-12	1750	0.49	14.8	980	102	132	69	DN1000	1120
		2500	0.69	12		99		82.2		
		3000	0.83	9.4		91		84		
23	500QHD-14	1750	0.49	17	980	114	132	71	DN1000	1560
		2500	0.69	14		119		80		
		3000	0.83	11		118		76		
24	500QHD-16	1890	0.53	19	980	137	160	73	DN1000	1660
		2700	0.75	16		145		81		
			0.90	13		143		78		

性能参数表 / Performance Parameters Table

序号 NO.	型号 Type	流量 Q Capacity (m³/h)	流量 Q Capacity (m³/s)	扬程 H Head (m)	转速 n Speed (r/min)	轴功率 P shaft Power (kW)	电机功率 P(kW) Motor Power	效率 η Eff. (%)	配套井筒 Wellbore diameter (mm)	泵重 Weight (kg)
25	500QHD-18	1960	0.54	22	980	159	200	74	DN1000	1860
		2800	0.78	18		167		82		
		3360	0.93	14		163		79		
26	500QHD-20	2100	0.58	25	980	189	220	74	DN1000	2000
		3000	0.83	20		199		82		
		3600	1.00	16		192		79		
27	500QHD-21	1260	0.35	23	980	114	160	69	DN1000	1600
		1800	0.50	21		129		80		
		2160	0.60	17		133		75		
28	500QHD-20.5	945	0.26	24.5	980	95.6	110	66.0	DN1000	1470
		1350	0.38	20.5		99.2		76.0		
		1620	0.45	15.5		96.4		71.0		
29	500QHD-22	1050	0.29	27	980	117	132	66	DN1000	1600
		1500	0.42	22		118		76		
		1800	0.50	17		117		71.5		
30	500QHD-25	1050	0.29	27	980	115	160	67.1	DN1000	1700
		1500	0.42	25		134		76		
		1800	0.50	21		146		71.8		
31	500QHD-30	910	0.25	32	1450	120	160	66	DN1000	1920
		1300	0.36	30		144		74		
		1560	0.43	26		156		71		
32	500QHD-34	945	0.26	37	1450	144	200	66	DN1000	2000
		1350	0.38	34		169		74		
		1620	0.45	29		180		71		
33	500QHD-38	980	0.27	41	1450	165	220	66	DN1000	2290
		1400	0.39	38		195		75		
		1680	0.47	33		212		71		
34	500QHD-42	1050	0.29	46	1450	196	250	66	DN1000	2420
		1500	0.42	42		230		75		
		1800	0.50	36		248		71		
35	600QHD-10	2170	0.60	12	740	99	132	69	DN1000	2190
		3100	0.86	10		107		79		
		3720	1.03	8		112		74		
36	600QHD-12	2170	0.60	15	740	127	160	70	DN1000	2280
		3100	0.86	12		127		80		
		3720	1.03	9		124		76		
37	600QHD-14	2240	0.62	17	740	144	185	72	DN1000	2370
		3200	0.89	14		152		81		
		3840	1.07	11		144		77		

性能参数表 / Performance Parameters Table

序号 NO.	型号 Type	流量 Q Capacity (m³/h)	流量 Q Capacity (m³/s)	扬程 H Head (m)	转速 n Speed (r/min)	轴功率 P shaft Power (kW)	电机功率 P(kW) Motor Power	效率 η Eff. (%)	配套井筒 Wellbore diameter (mm)	泵重 Weight (kg)
38	600QHD-16	2380	0.66	19	740	167	220	74	DN1000	2610
		3400	0.94	16		183		81		
		4080	1.13	13		178		78		
39	600QHD-18	2520	0.70	21	740	192	250	75	DN1000	2750
		3600	1.00	18		215		82		
		4320	1.20	15		224		79		
40	600QHD-15	2100	0.58	17	740	139	185	70	DN1000	2350
		3000	0.83	15		153		80		
		3600	1.00	13		168		76		
41	600QHD-17	2240	0.62	18	740	155	220	71	DN1000	2690
		3200	0.89	17		184		81		
		3840	1.07	14		183		77		
42	600QHD-20	2450	0.68	22	740	199	280	72	DN1000	2860
		3500	0.97	20		235		81		
		4200	1.17	16		235		78		
43	600QHD-23	1960	0.54	25	980	193	280	70	DN1000	2590
		2800	0.78	23		222		79		
		3360	0.93	17		207		77		
44	600QHD-25	2100	0.58	28	980	222	315	71	DN1000	2740
		3000	0.83	25		255		80		
		3600	1.00	20		245		78		
45	600QHD-26	1260	0.35	28	980	137	200	70	DN1000	2230
		1800	0.50	26		159		80		
		2160	0.60	22		168		77		
46	600QHD-28	1330	0.37	30	980	156	220	70	DN1000	2340
		1900	0.53	28		181		80		
		2280	0.63	24		194		77		
47	600QHD-30	1400	0.39	33	980	176	250	71	DN1000	2460
		2000	0.56	30		204		80		
		2400	0.67	26		218		78		
48	600QHD-31	1610	0.45	34	980	223	280	67	DN1100	2640
		2300	0.64	31		259		75		
		2760	0.77	26		272		72		
49	600QHD-32	1680	0.47	35	980	236	315	68	DN1100	2790
		2400	0.67	32		275		76		
		2880	0.80	27		290		73		

性能参数表 / Performance Parameters Table

序号 NO.	型号 Type	流量 Q Capacity (m³/h)	流量 Q Capacity (m³/s)	扬程 H Head (m)	转速 n Speed (r/min)	轴功率 P shaft Power (kW)	电机功率 P(kW) Motor Power	效率 η Eff. (%)	配套井筒 Wellbore diameter (mm)	泵重 Weight (kg)
50	600QHD-35	1750	0.49	38	980	263	355	69	DN1100	3380
		2500	0.69	35		310		77		
		3000	0.83	30		331		74		
51	700QHD-8	2800	0.78	10	740	102	132	75	DN1100	2240
		4000	1.11	8		106		82		
		4800	1.33	6		98		80		
52	700QHD-9	3150	0.88	11	740	126	160	76	DN1100	2330
		4500	1.25	9		133		83		
		5400	1.50	7		125		80		
53	700QHD-10	3500	0.97	13	740	39	200	77	DN1100	2420
		5000	1.39	10		42		84		
		6000	1.67	8		49		81		
54	700QHD-11	4200	1.17	14	740	198	250	78	DN1100	2810
		6000	1.67	11		212		85		
		7200	2.00	9		203		82		
55	700QHD-18	3010	0.84	20	740	238	315	69	DN1350	3170
		4300	1.19	18		270		78		
		5160	1.43	13		244		75		
56	700QHD-20	3150	0.88	22	740	274	400	69	DN1350	4300
		4500	1.25	20		314		78		
		5400	1.50	15		294		75		
57	700QHD-22	3500	0.97	24	740	327	450	70	DN1350	440
		5000	1.39	22		379		79		
		6000	1.67	17		366		76		
58	700QHD-24	3850	1.07	26	740	390	530	70	DN1350	4500
		5500	1.53	24		455		79		
		6600	1.83	19		450		76		
59	700QHD-27	2310	0.64	30	740	270	355	70	DN1350	4300
		3300	0.92	27		317		77		
		3960	1.10	23		335		74		
60	700QHD-30	2450	0.68	33	740	315	450	70	DN1350	4500
		3500	0.97	30		374		77		
		4200	1.17	26		402		74		
61	700QHD-32	1890	0.53	35	980	265	355	68	DN1350	4300
		2700	0.75	32		314		75		
		3240	0.90	28		337		72		

性能参数表 / Performance Parameters Table

序号 NO.	型号 Type	流量 Q Capacity (m³/h)	流量 Q Capacity (m³/s)	扬程 H Head (m)	转速 n Speed (r/min)	轴功率 P shaft Power (kW)	电机功率 P(kW) Motor Power	效率 η Eff. (%)	配套井筒 Wellbore diameter (mm)	泵重 Weight (kg)
62	700QHD-35	1960	0.54	38	980	298	400	68	DN1350	4400
		2800	0.78	35		356		75		
		3360	0.93	30		382		72		
63	700QHD-37	2030	0.56	40	980	323	450	68	DN1350	4500
		2900	0.81	37		385		76		
		3480	0.97	31		403		73		
64	700QHD-40	2100	0.58	43	980	360	500	68	DN1350	4600
		3000	0.83	40		430		76		
		3600	1.00	34		457		73		
65	700QHD-42	2520	0.70	46	980	465	630	68	DN1500	4800
		3600	1.00	42		542		76		
		4320	1.20	36		589		72		
66	700QHD-45	2660	0.74	49	980	522	710	68	DN1500	7000
		3800	1.06	45		613		76		
		4560	1.27	39		673		72		
67	700QHD-50	2800	0.78	54	980	597	800	69	DN1500	7530
		4000	1.11	50		708		77		
		4800	1.33	43		760		74		
68	800QHD-12	4550	1.26	15	740	262	315	71.0	DN1200	3500
		6500	1.81	12		256		83.0		
		7800	2.17	10		240		84.0		
69	800QHD-14	4900	1.36	18	740	331	355	71.0	DN1200	4580
		7000	1.94	14		318		84.0		
		8400	2.33	11		283		85.0		
70	800QHD-16	5250	1.46	20	740	401	450	72.0	DN1200	4680
		7500	2.08	16		385		85.0		
		9000	2.50	12		351		86.0		
71	800QHD-18	5600	1.56	22	740	466	500	72.0	DN1200	4780
		8000	2.22	18		462		85.0		
		9600	2.67	14		426		86.0		
72	800QHD-25	4200	1.17	28	740	443	630	71.0	DN1600	4980
		6000	1.67	25		511		80.0		
			2.00	20		517		77.0		
73	800QHD-28	4550	1.26	31	740	541	710	71.0	DN1600	7300
		6500	1.81	28		620		80.0		
		7800	2.17	23		635		77.0		

性能参数表 / Performance Parameters Table

序号 NO.	型号 Type	流量 Q Capacity (m³/h)	流量 Q Capacity (m³/s)	扬程 H Head (m)	转速 n Speed (r/min)	轴功率 P shaft Power (kW)	电机功率 P(kW) Motor Power	效率 η Eff. (%)	配套井筒 Wellbore diameter (mm)	泵重 Weight (kg)
74	800QHD-31	4900	1.36	34	740	639	800	71.0	DN1600	7830
		7000	1.94	31		739		80.0		
		8400	2.33	25		743		77.0		
75	800QHD-33	2800	0.78	36	740	392	530	70	DN1600	5540
		4000	1.11	33		468		77		
		4800	1.33	28		502		74		
76	800QHD-35	3150	0.88	38	740	473	630	69	DN1600	5800
		4500	1.25	35		565		76		
		5400	1.50	30		597		74		
77	800QHD-38	3500	0.97	41	740	564	760	70	DN1600	7640
		5000	1.39	38		672		77		
		6000	1.67	33		727		74		
78	900QHD-9	6400	1.78	11	590	263	280	73	DN1500	5850
		8000	2.22	9		242		81		
		9600	2.67	7		220		82		
79	900QHD-10	6400	1.78	12	590	287	315	73	DN1500	5940
		8000	2.22	10		269		81		
		9600	2.67	8		249		82		
80	900QHD-11	6800	1.89	13	590	331	355	74	DN1500	6040
		8500	2.36	11		311		82		
		10200	2.83	9		295		83		
81	900QHD-12	7200	2.00	14	590	372	400	76	DN1500	6640
		9000	2.50	12		356		83		
		10800	3.00	10		335		83		
82	900QHD-13	7440	2.07	16	590	422	450	76	DN1500	6770
		9300	2.58	13		399		83		
		11160	3.10	11		383		83		
83	900QHD-14	7600	2.11	17	590	463	500	76	DN1500	6890
		9500	2.64	14		437		83		
		11400	3.17	11		414		84		
84	900QHD-15	8000	2.22	18	590	511	560	76	DN1500	7020
		10000	2.78	15		492		83		
		12000	3.33	12		467		84		
85	900QHDX-38	4200	1.17	41	740	670	1000	70	DN1700	10000
		6000	1.67	38		807		77		
		7200	2.00	32		848		74		

性能参数表 / Performance Parameters Table

序号 NO.	型号 Type	流量 Q Capacity (m³/h)	流量 Q Capacity (m³/s)	扬程 H Head (m)	转速 n Speed (r/min)	轴功率 P shaft Power (kW)	电机功率 P(kW) Motor Power	效率 η Eff. (%)	配套井筒 Wellbore diameter (mm)	泵重 Weight (kg)
86	900QHDX-43	4550	1.26	47	740	823	1120	71	DN1700	10300
		6500	1.81	43		983		78		
		7800	2.17	37		1049		75		
87	900QHDX-48	4900	1.36	52	740	992	1350	70	DN1700	11400
		7000	1.94	48		1174		78		
		8400	2.33	41		1251		75		
88	1000QHD-8	8800	2.44	11	495	356	400	74	DN1500	7000
		11000	3.06	8		289		83		
		12100	3.36	7		269		81		
89	1000QHD-9	9600	2.67	12	495	419	450	75	DN1500	7100
		12000	3.33	9		350		84		
		13200	3.67	8		321		84		
90	1000QHD-10	10000	2.78	13	495	472	500	75	DN1500	7250
		12500	3.47	10		406		84		
		13750	3.82	9		379		84		
91	1000QHD-14	9600	2.67	15	495	538	630	73	DN1600	8060
		12000	3.33	14		539		85		
		13200	3.67	9		389		86		
92	1000QHD-15	10400	2.89	19	495	697	710	76	DN1600	8220
		13000	3.61	15		625		85		
		14300	3.97	11		498		86		
93	1000QHD-20	6510	1.81	24	590	565	710	76	DN1700	8070
		9300	2.58	20		611		83		
		11160	3.10	15		574		80		
94	1000QHD-22	7000	1.94	27	590	672	800	77	DN1700	8280
		10000	2.78	22		718		84		
		12000	3.33	17		668		81		
95	1000QHDX-26	6650	1.85	29	590	730	1000	72	DN1700	10340
		9500	2.64	26		841		80		
		11400	3.17	21		836		78		
96	1000QHDX-29	7000	1.94	32	590	848	1120	72	DN1700	10540
		10000	2.78	29		988		80		
		12000	3.33	23		973		78		
97	1000QHDX-35	6000	1.67	38	590	875	1120	71	DN1700	10540
		7500	2.08	35		917		78		
		9000	2.50	30		981		75		

性能参数表 / Performance Parameters Table

序号 NO.	型号 Type	流量 Q Capacity (m³/h)	流量 Q Capacity (m³/s)	扬程 H Head (m)	转速 n Speed (r/min)	轴功率 P shaft Power (kW)	电机功率 P(kW) Motor Power	效率 η Eff. (%)	配套井筒 Wellbore diameter (mm)	泵重 Weight (kg)
98	1000QHDX-39	6400	1.78	41	590	1007	1250	71	DN1700	10740
		8000	2.22	39		1090		78		
		9600	2.67	33		1148		75		
99	1200QHD-8.5	10800	3.00	12	425	434	450	78	DN1900	8050
		13500	3.75	9		368		85		
		15525	4.31	6		294		86		
100	1200QHD-10	11200	3.11	13	425	509	530	78	DN1900	8200
		14000	3.89	10		449		85		
		16100	4.47	8		382		86		
101	1200QHD-11	12000	3.33	14	425	587	630	78	DN1900	8380
		15000	4.17	11		529		85		
		17250	4.79	9		480		86		
102	1200QHD-12	12800	3.56	15	425	671	710	78	DN1900	8560
		16000	4.44	12		616		85		
		18400	5.11	10		558		86		
103	1200QHDX-19	9600	2.67	22	495	748	900	78	DN2000	9850
		12000	3.33	19		740		84		
		14400	4.00	15		703		82		
104	1200QHDX-21	10000	2.78	25	495	852	1000	79	DN2000	10050
		12500	3.47	21		842		85		
		15000	4.17	16		808		83		
105	1200QHDX-22	10400	2.89	26	495	926	1120	79	DN2000	10250
		13000	3.61	22		917		85		
		15600	4.33	17		871		83		
106	1200QHDX-28	8050	2.24	32	495	975	1250	72	DN1900	10750
		11500	3.19	28		1097		80		
		13800	3.83	22		1061		78		
107	1200QHDX-30	8400	2.33	34	495	1066	1400	73	DN1900	10980
		12000	3.33	30		1211		81		
		14400	4.00	24		1192		79		
108	1400QHDX-12.5	13600	3.78	15	425	726	800	74	DN2000	14100
		17000	4.72	13		681		85		
		5.43	9	530		86				
109	1400QHDX-13	14400	4.00	15	425	795	900	74	DN2000	14650
		18000	5.00	13		750		85		
		20700	5.75	9		594		86		

性能参数表 / Performance Parameters Table

序号 NO.	型号 Type	流量 Q Capacity (m³/h)	流量 Q Capacity (m³/s)	扬程 H Head (m)	转速 n Speed (r/min)	轴功率 P shaft Power (kW)	电机功率 P(kW) Motor Power	效率 η Eff. (%)	配套井筒 Wellbore diameter (mm)	泵重 Weight (kg)
110	1400QHDX-14	15200	4.22	17	425	936	1000	73	DN2000	14850
		19000	5.28	14		863		84		
		21850	6.07	10		692		86		
111	1400QHDX-15	16000	4.44	18	425	1037	1120	74	DN2000	15050
		20000	5.56	15		961		85		
		23000	6.39	11		792		87		
112	1400QHDX-16	16800	4.67	19	425	1051	1250	81	DN2000	15250
		21000	5.83	16		1065		86		
		24150	6.71	12		930		87		
113	1400QHDX-18	12800	3.56	20	425	920	1000	77	DN2200	14450
		16000	4.44	18		934		84		
		18400	5.11	15		898		81		
114	1400QHDX-20	13600	3.78	23	425	1060	1250	79	DN2200	14850
		17000	4.72	20		1090		85		
		19550	5.43	16		1065		81		
115	1400QHDX-22	14400	4.00	25	425	1226	1400	80	DN2200	15080
		18000	5.00	22		1270		85		
		20700	5.75	18		1238		82		
116	1600QHDX-9	20000	5.56	12	330	869	900	74	DN2500	15500
		25000	6.94	9		713		86		
		30000	8.33	6		564		87		
117	1600QHDX-10	20800	5.78	13	330	996	1000	74	DN2500	15700
		26000	7.22	10		834		85		
		31200	8.67	7		709		84		
118	1600QHDX-11	21600	6.00	14	330	1114	1120	74	DN2500	15900
		27000	7.50	11		952		85		
		32400	9.00	8		841		84		
119	1600QHDX-12	22400	6.22	15	330	1221	1250	75	DN2500	16100
		28000	7.78	12		1065		86		
		33600	9.33	9		969		85		
120	1600QHDX-13	23200	6.44	16	330	1331	1400	76	DN2500	16300
		29000	8.06	13		1195		86		
		34800	9.67	10		1090		87		
121	1600QHDX-14	24000	6.67	17	330	1463	1600	76	DN2500	17000
		30000	8.33	14		1331		86		
		10.00	11	1240		87				

性能曲线图 / Performance curve

350QHD-8 型潜水混流泵性能曲线图 350QHD-8 type submersible Mixed-flow pump performance curve

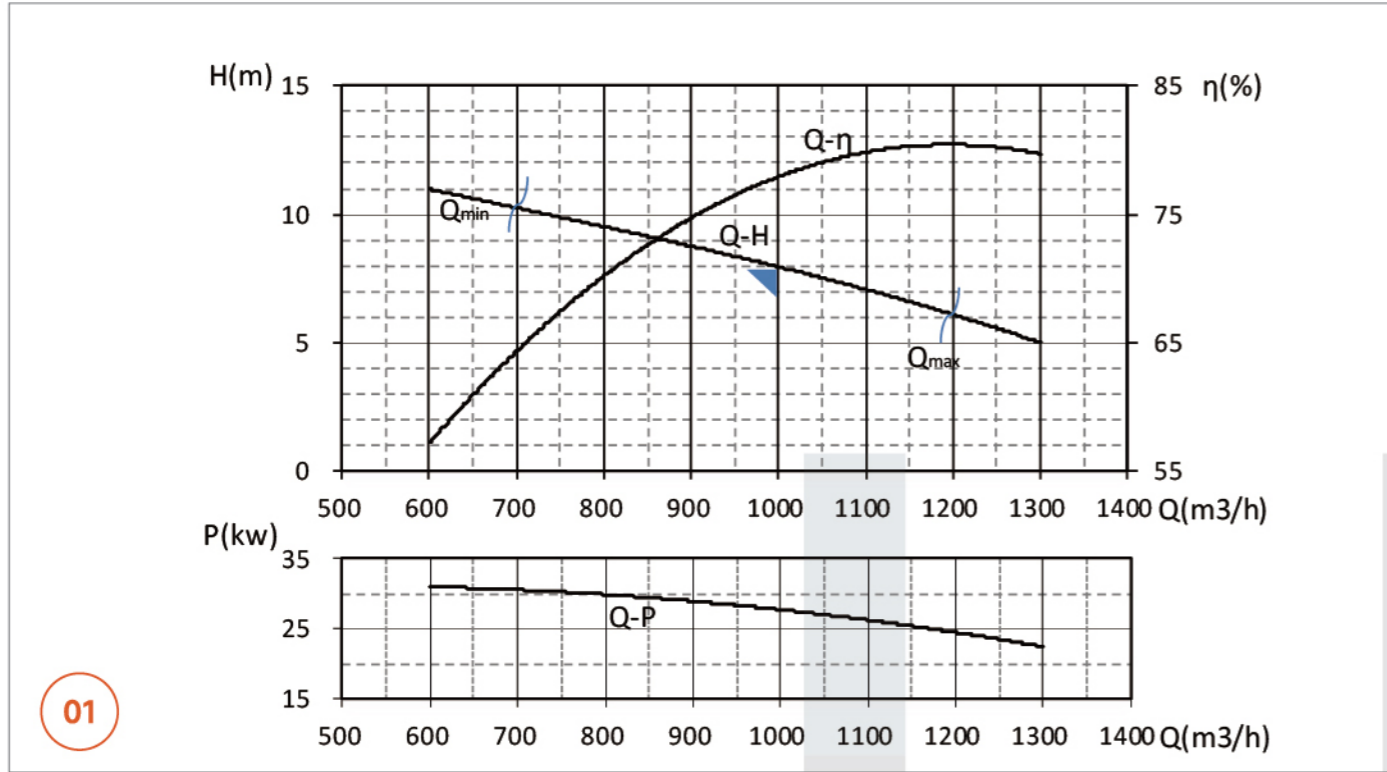

性能曲线图 / Performance curve

350QHD-11 型潜水混流泵性能曲线图 350QHD-11 type submersible Mixed-flow pump performance curve

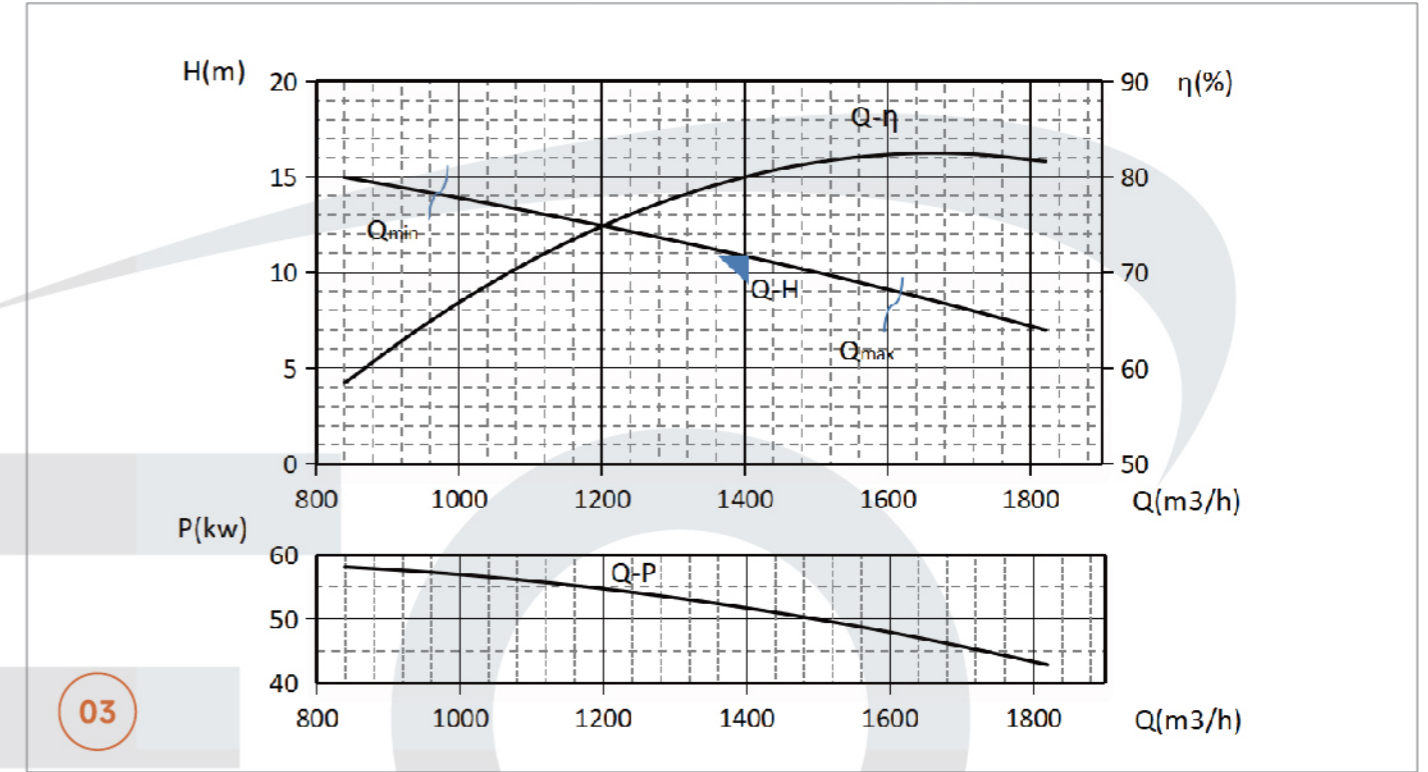

350QHD-9 型潜水混流泵性能曲线图 350QHD-9 type submersible Mixed-flow pump performance curve

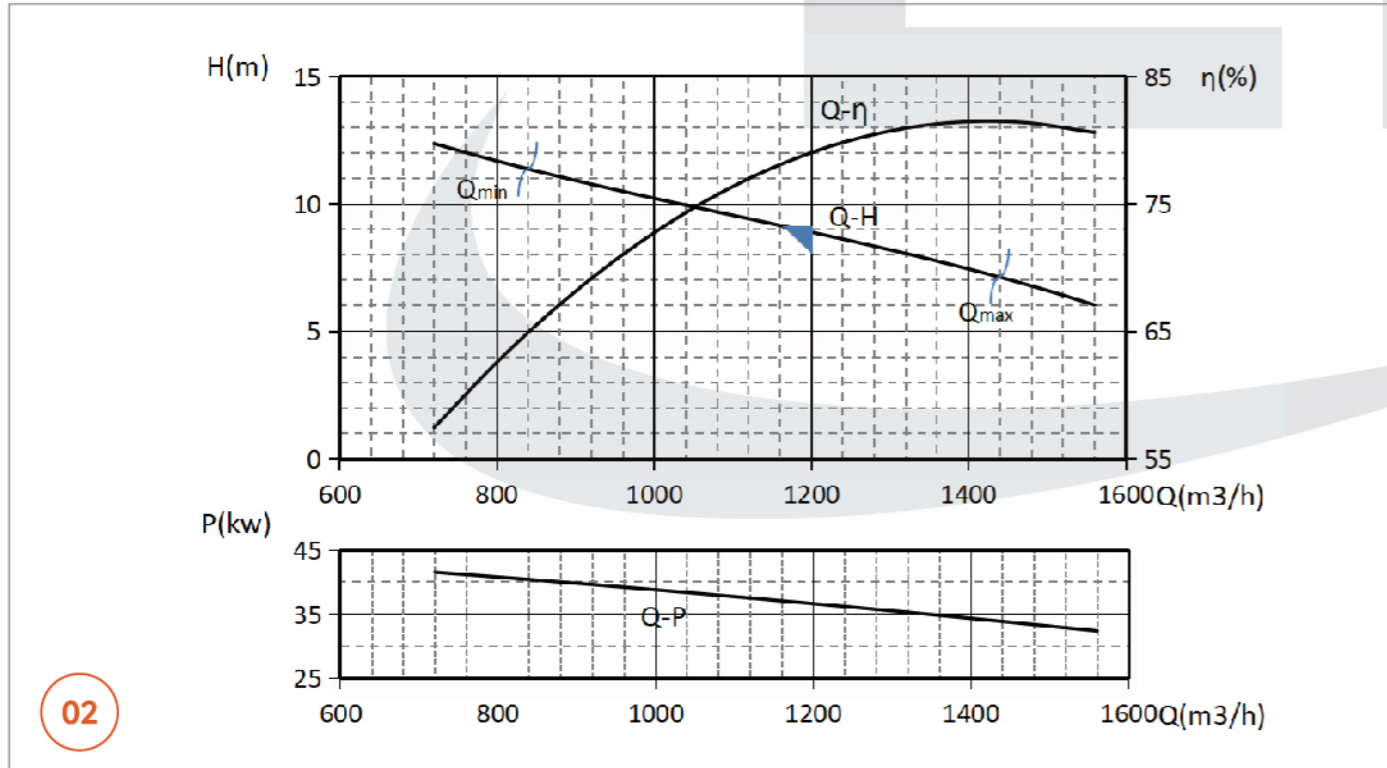

350QHD-13 型潜水混流泵性能曲线图 350QHD-13 type submersible Mixed-flow pump performance curve

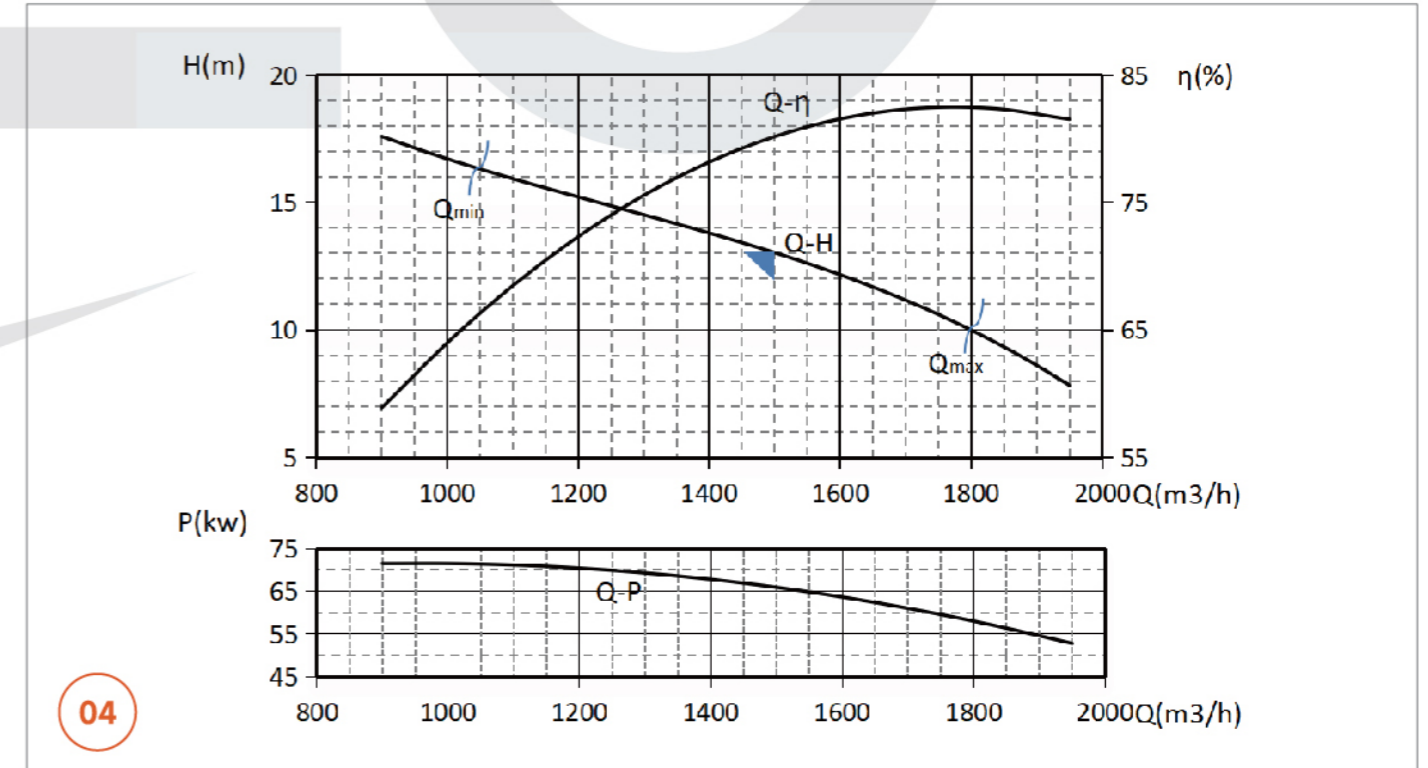

性能曲线图 / Performance curve

350QHD-12 型潜水混流泵性能曲线图 350QHD-12 type submersible Mixed-flow pump performance curve

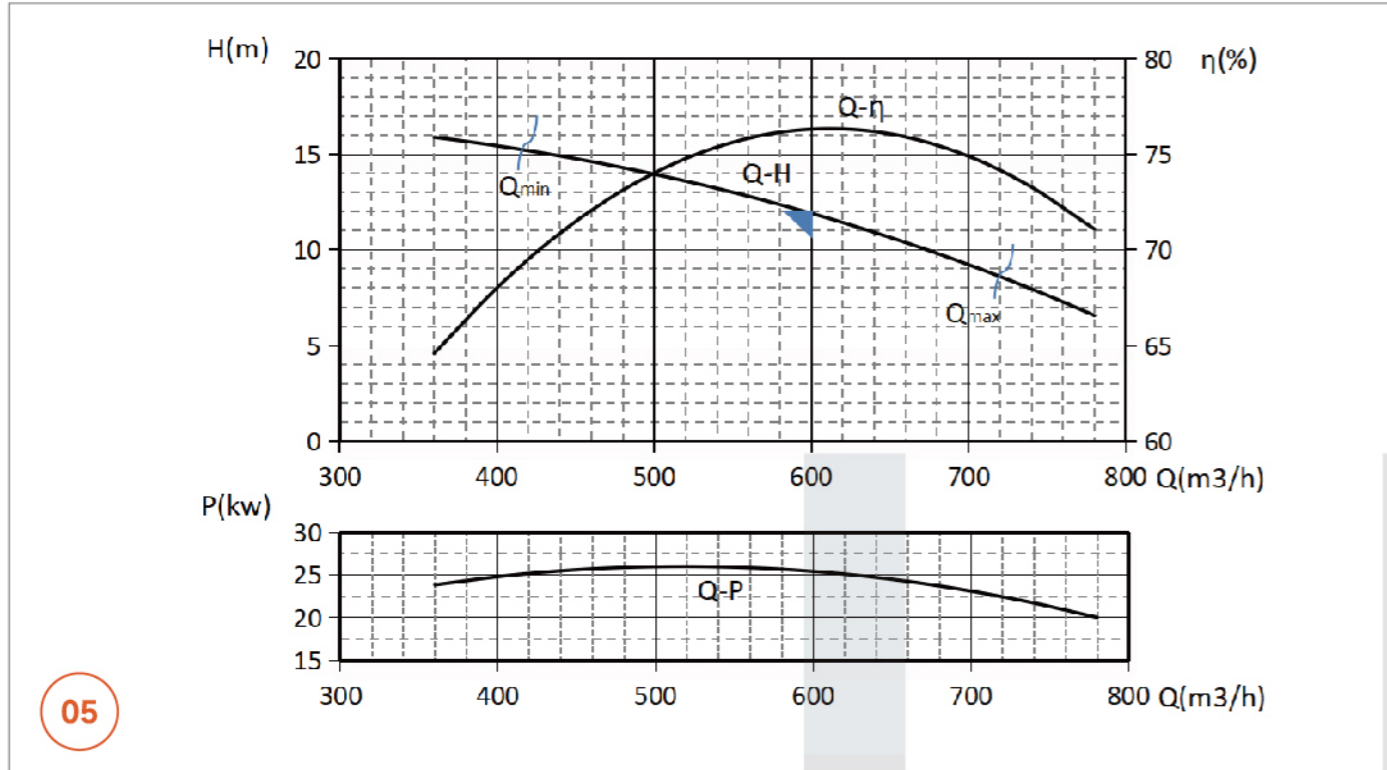

性能曲线图 / Performance curve

350QHD-16 型潜水混流泵性能曲线图 350QHD-16 type submersible Mixed-flow pump performance curve

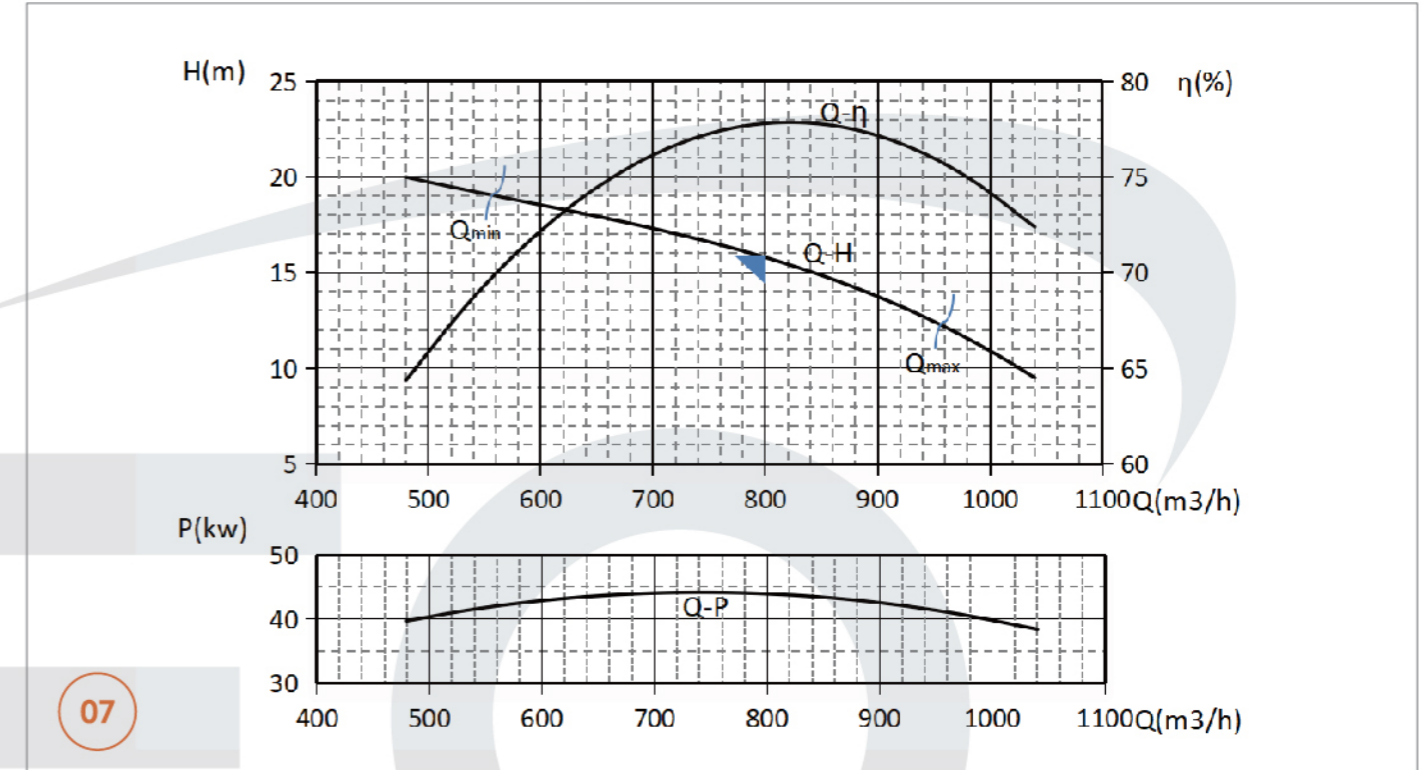

350QHD-14 型潜水混流泵性能曲线图 350QHD-14 type submersible Mixed-flow pump performance curve

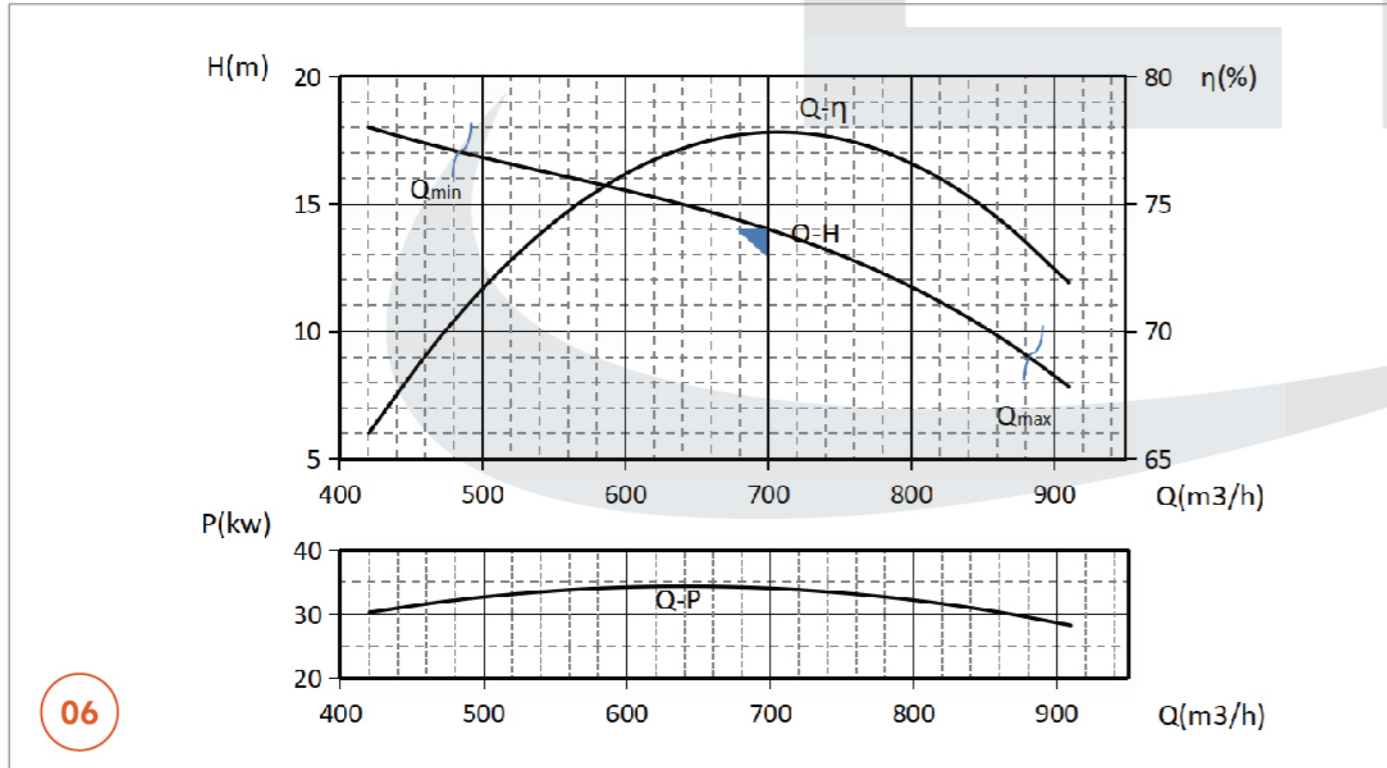

350QHD-17 型潜水混流泵性能曲线图 350QHD-17 type submersible Mixed-flow pump performance curve

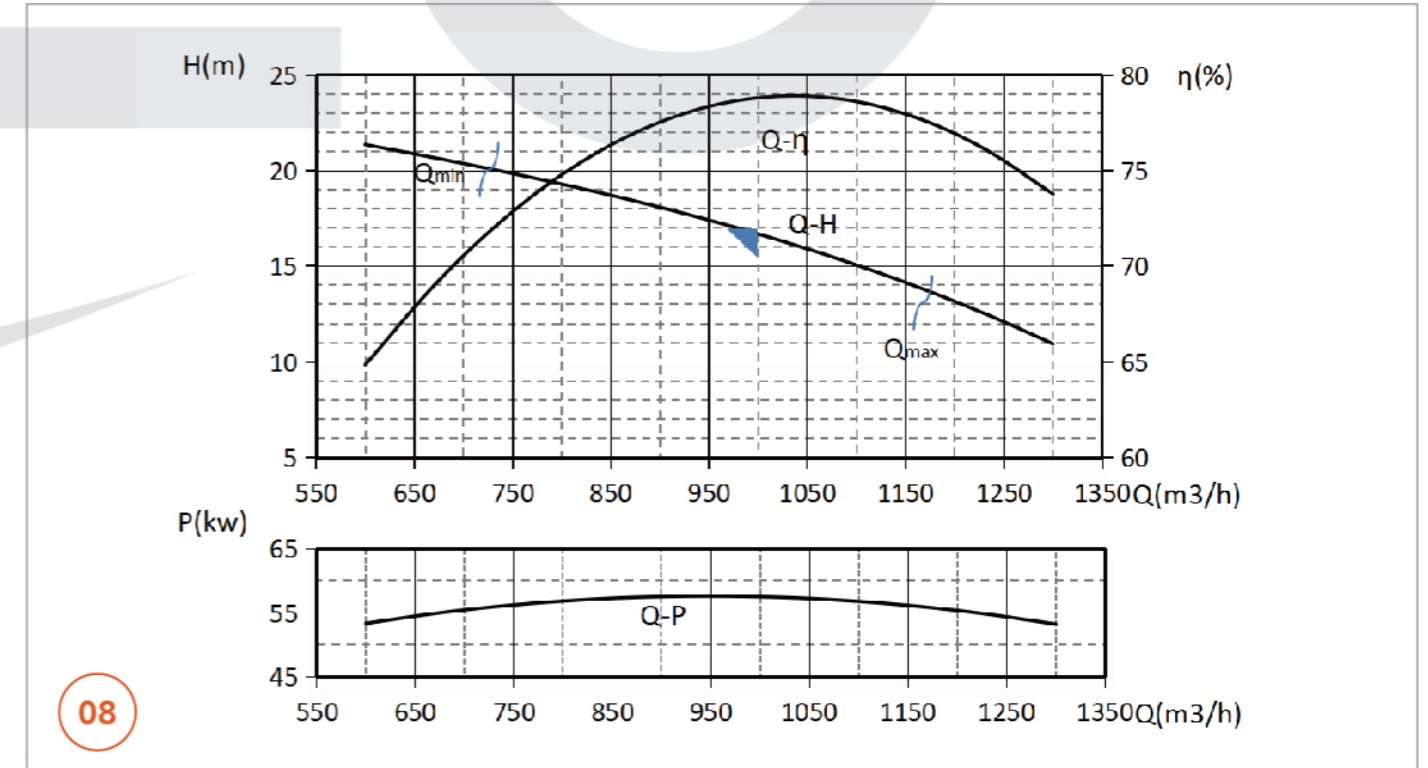

性能曲线图 / Performance curve

350QHD-18 型潜水混流泵性能曲线图 350QHD-18 type submersible Mixed-flow pump performance curve

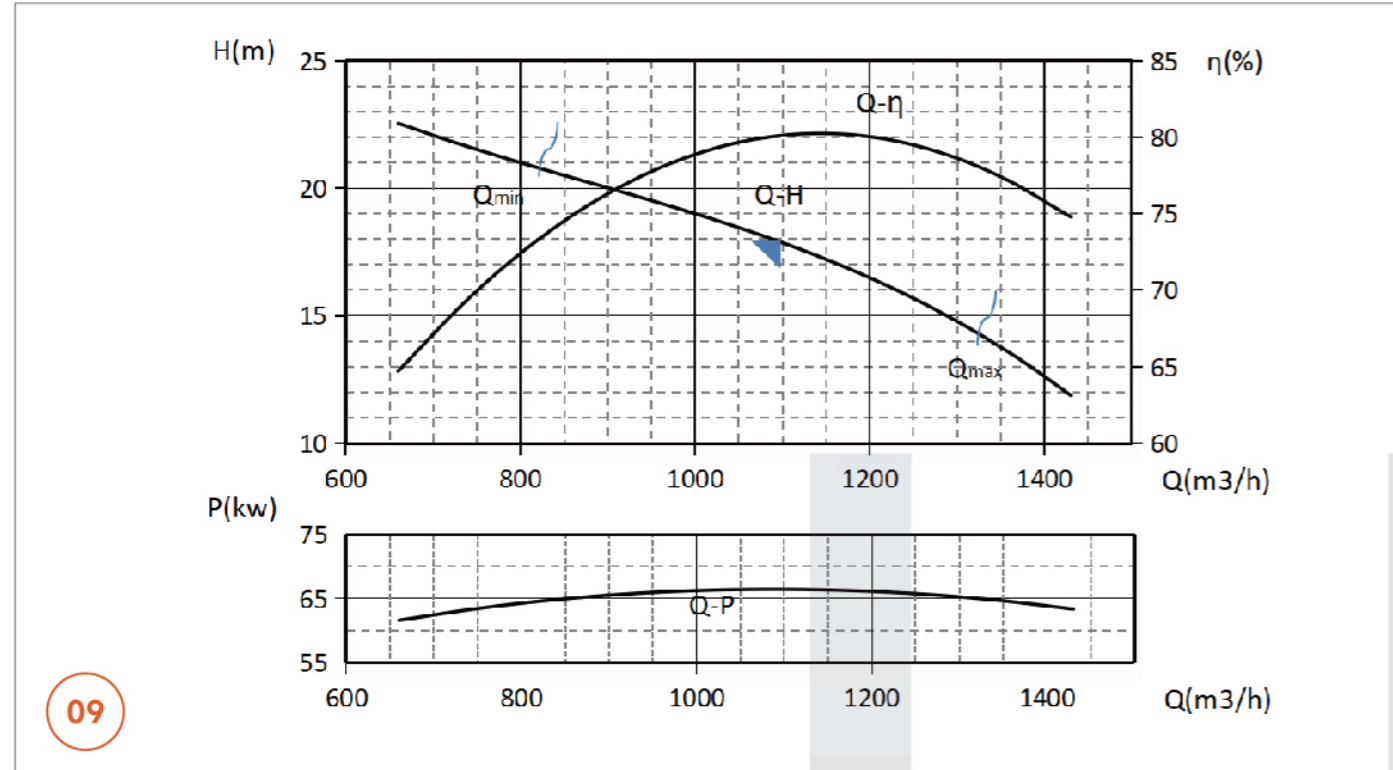

性能曲线图 / Performance curve

350QHD-22 型潜水混流泵性能曲线图 350QHD-22 type submersible Mixed-flow pump performance curve

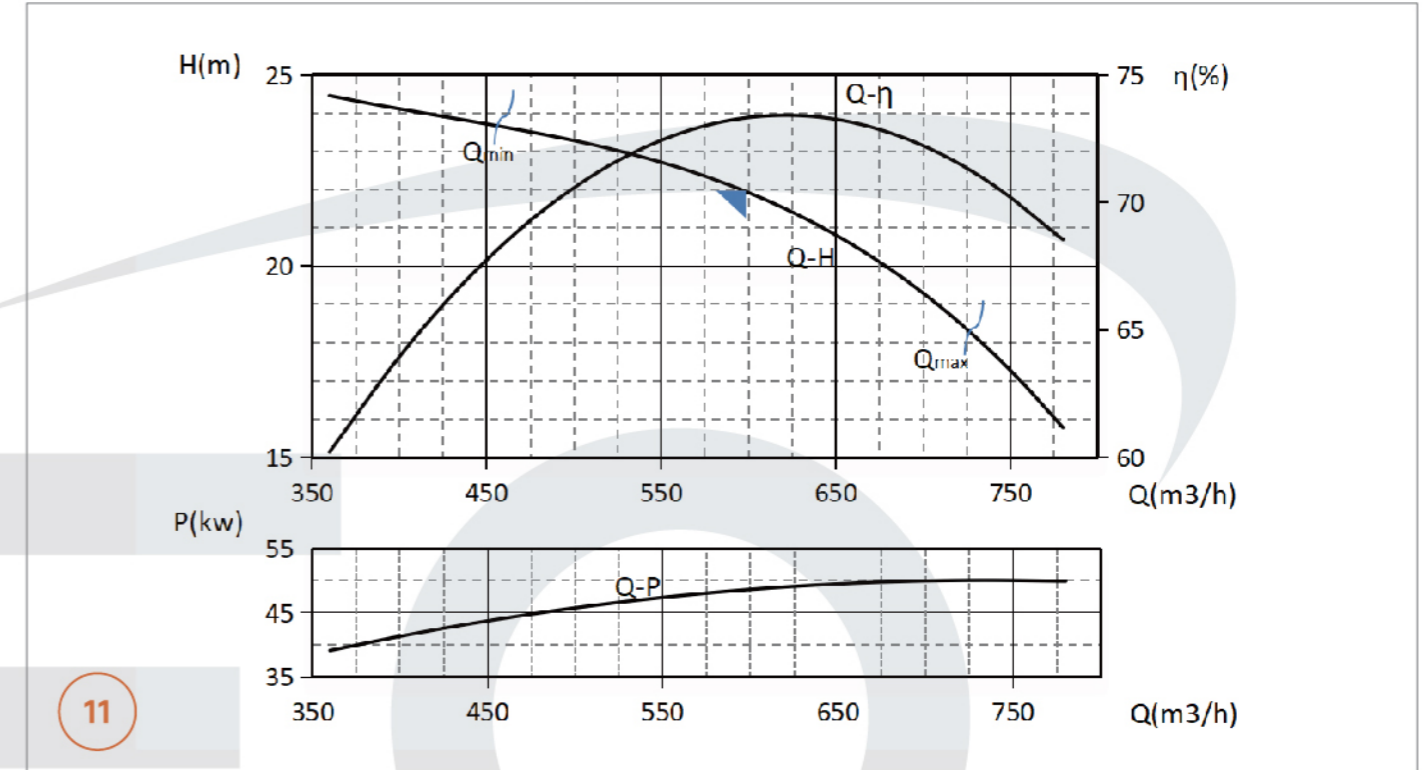

350QHD-19 型潜水混流泵性能曲线图 350QHD-19 type submersible Mixed-flow pump performance curve

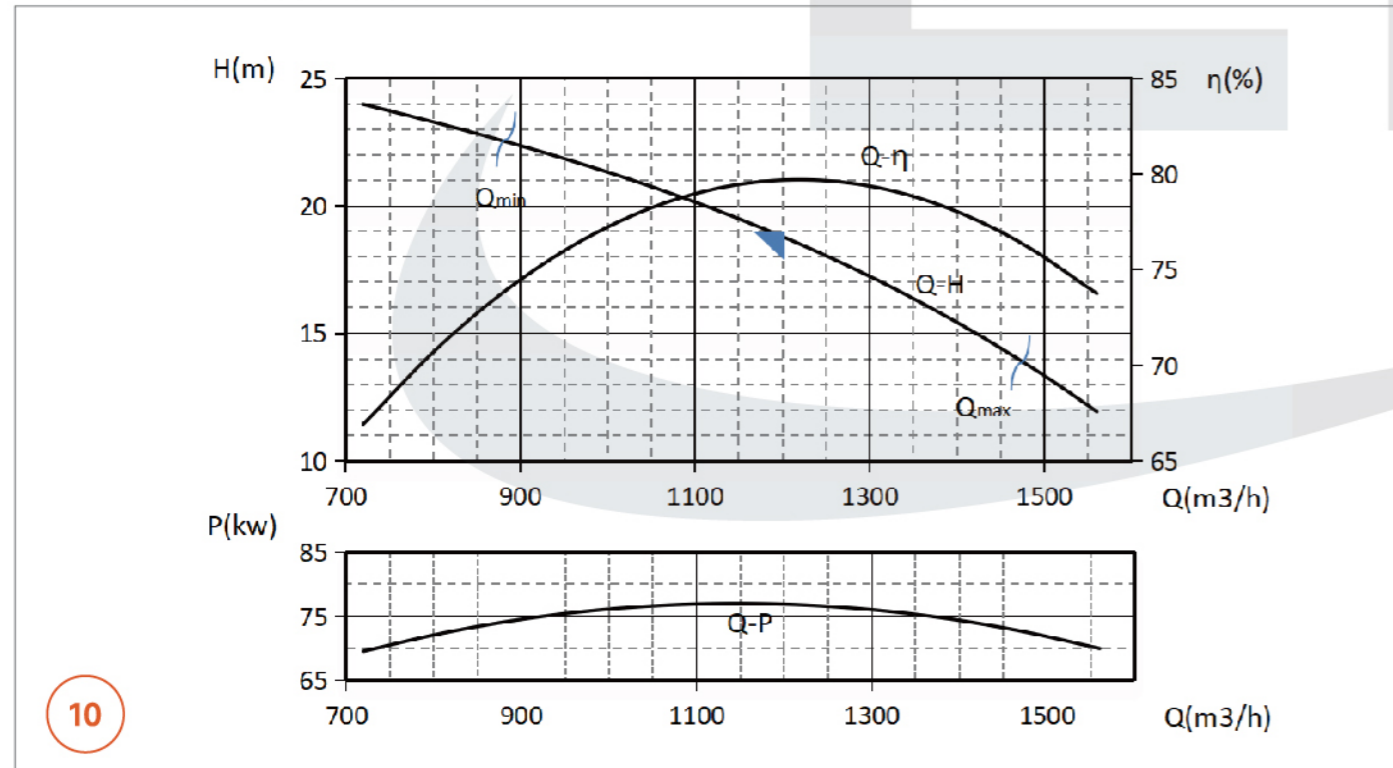

350QHD-24 型潜水混流泵性能曲线图 350QHD-24 type submersible Mixed-flow pump performance curve

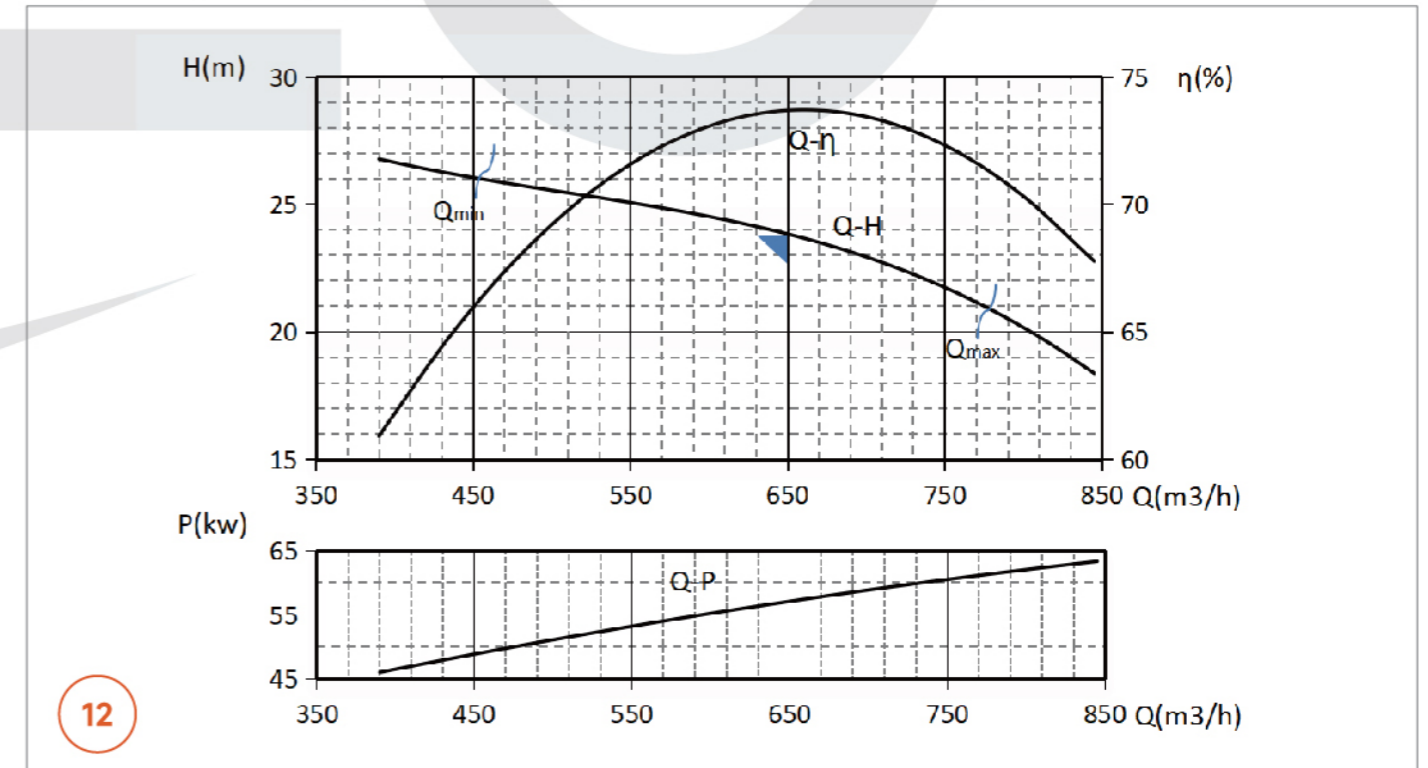

性能曲线图 / Performance curve

350QHD-26 型潜水混流泵性能曲线图 350QHD-26 type submersible Mixed-flow pump performance curve

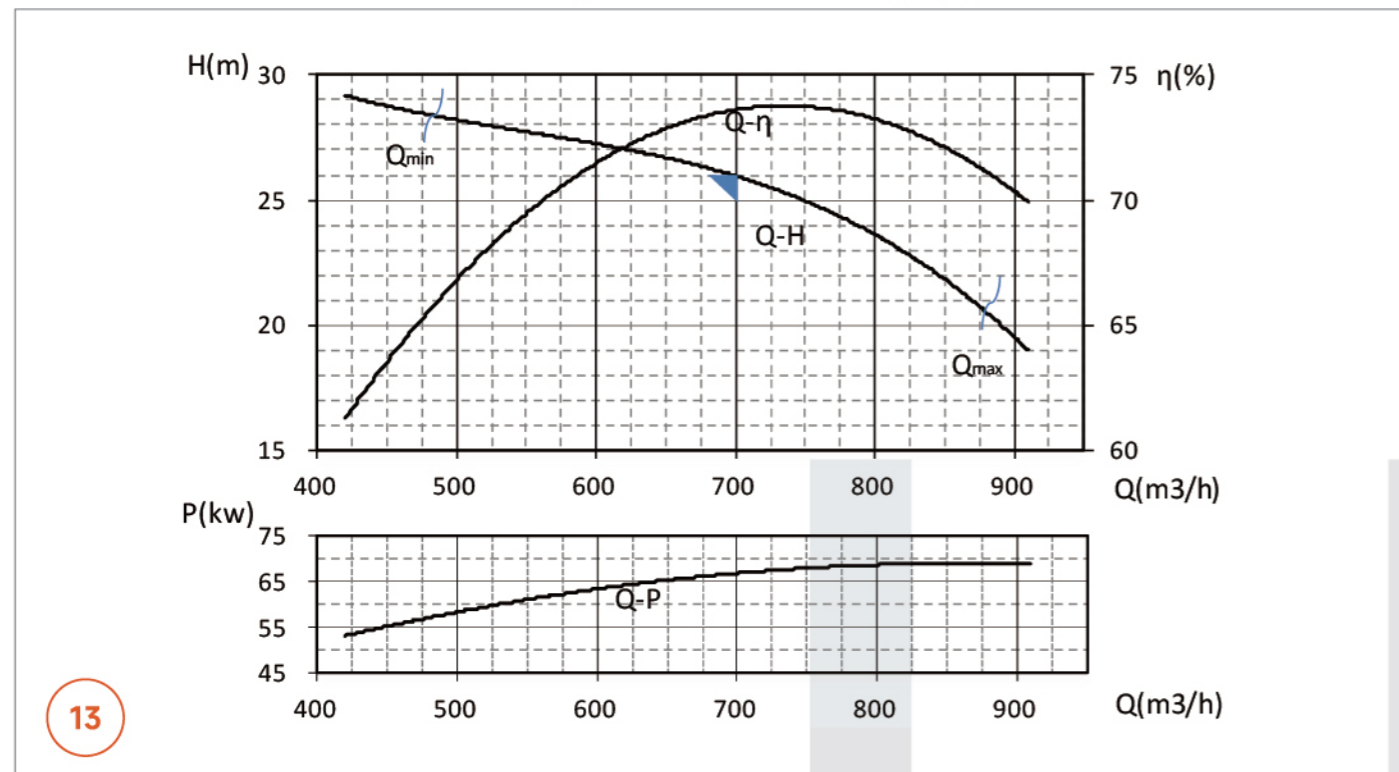

13

性能曲线图 / Performance curve

350QHD-30 型潜水混流泵性能曲线图 350QHD-30 type submersible Mixed-flow pump performance curve

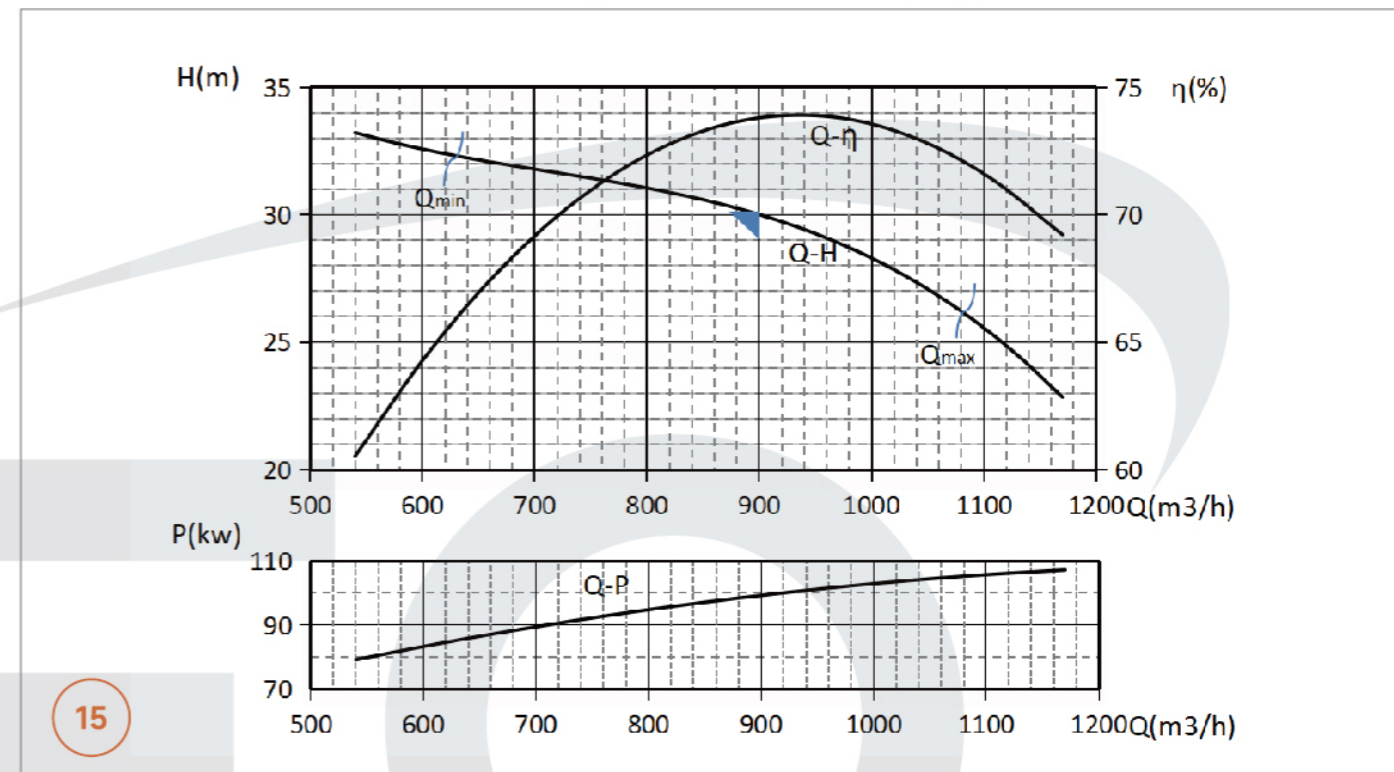

15

350QHD-28 型潜水混流泵性能曲线图 350QHD-28 type submersible Mixed-flow pump performance curve

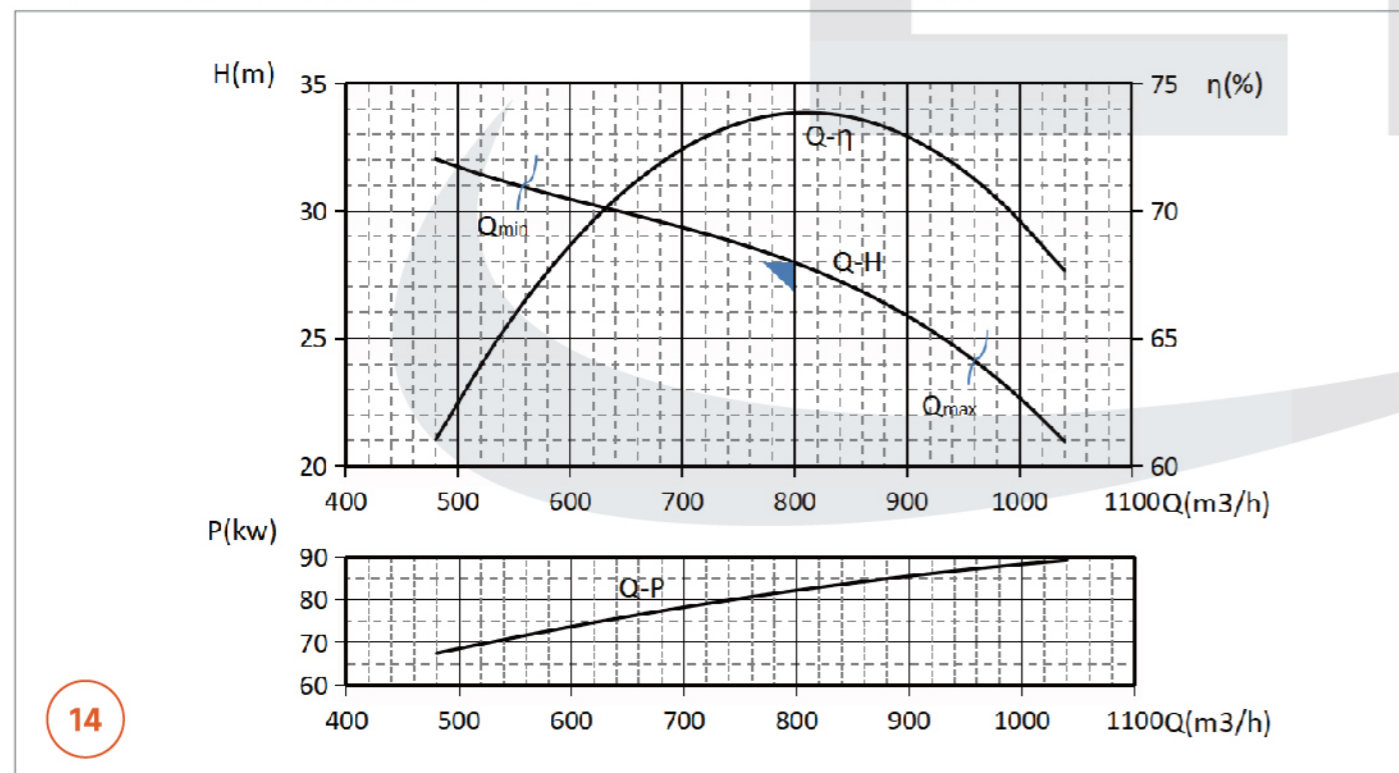

14

350QHD-32 型潜水混流泵性能曲线图 350QHD-32 type submersible Mixed-flow pump performance curve

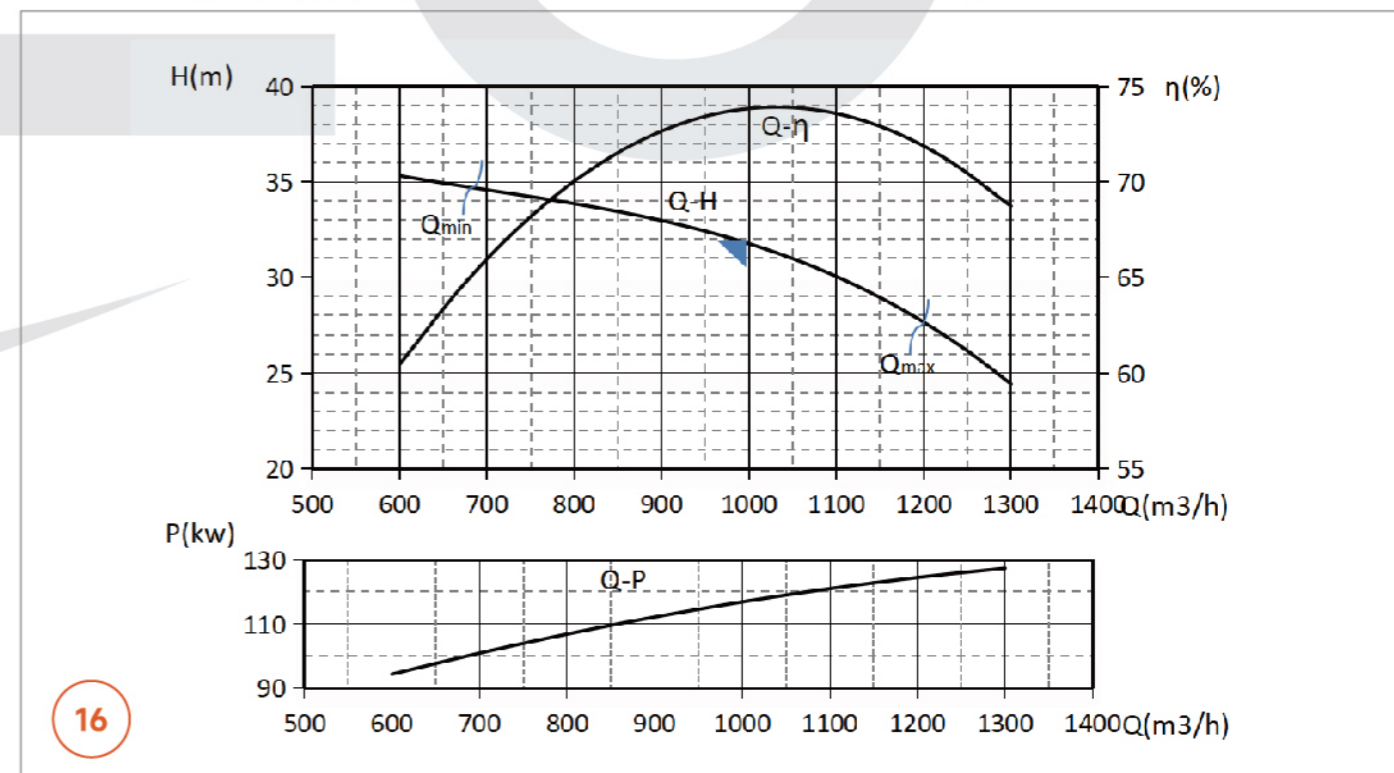

16

性能曲线图 / Performance curve

500QHD-8 型潜水混流泵性能曲线图 500QHD-8 type submersible Mixed-flow pump performance curve

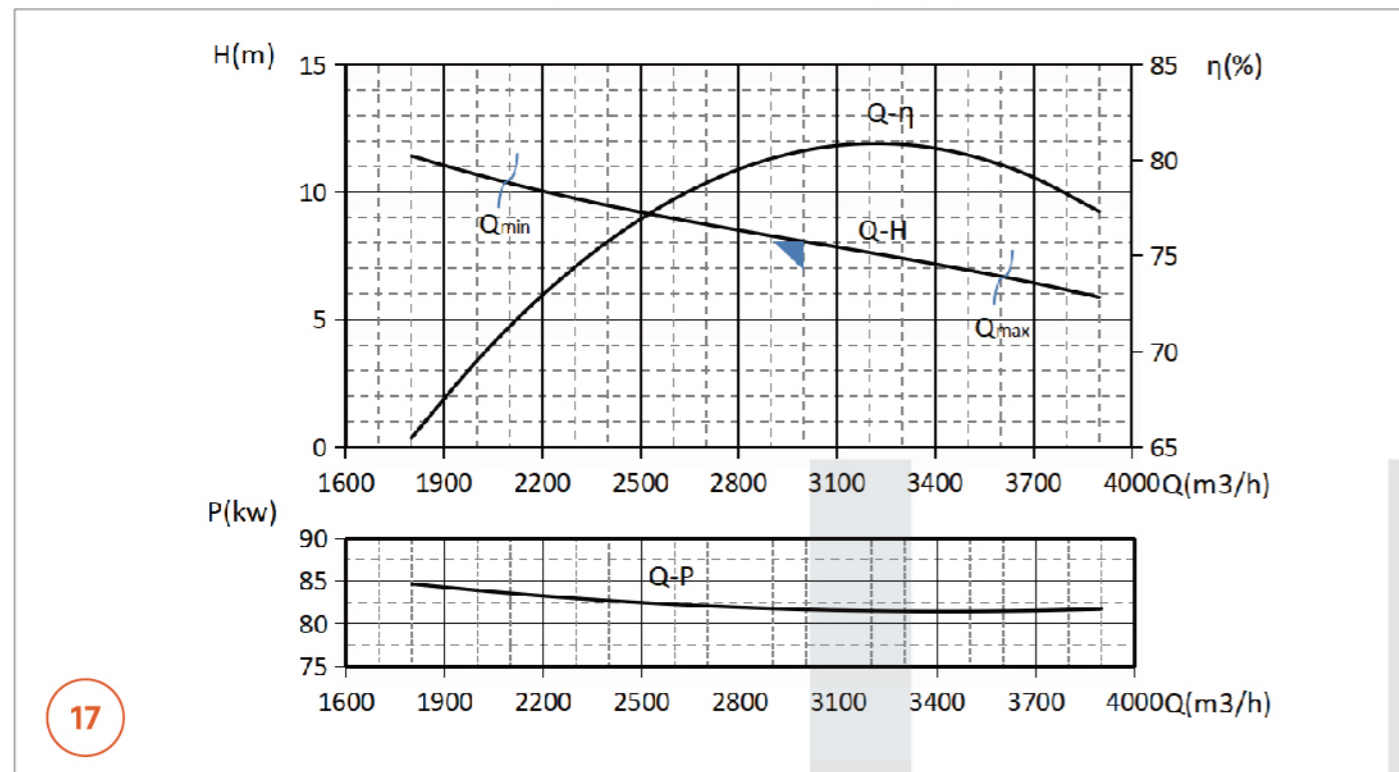

17

性能曲线图 / Performance curve

500QHD-9 型潜水混流泵性能曲线图 500QHD-9 type submersible Mixed-flow pump performance curve

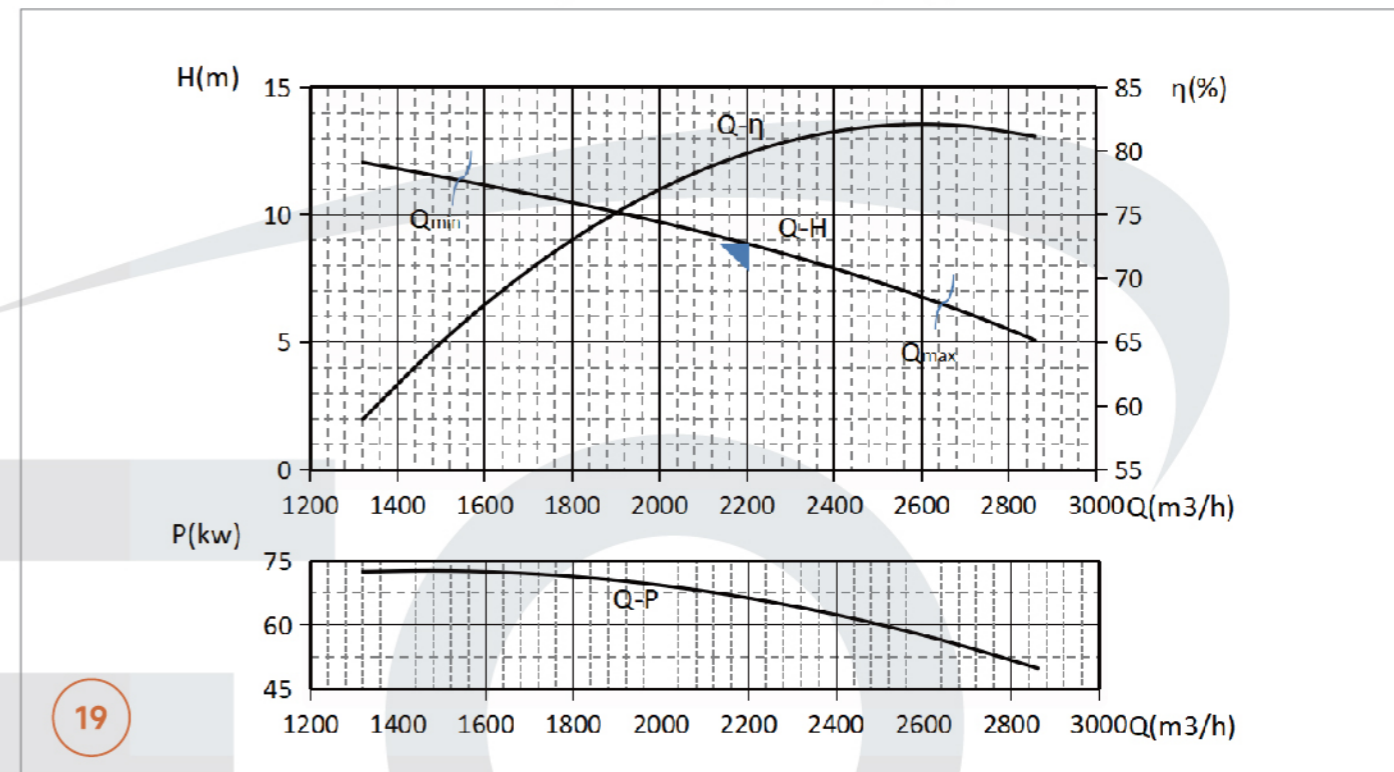

19

500QHD-7.5 型潜水混流泵性能曲线图 500QHD-7.5 type submersible Mixed-flow pump performance curve

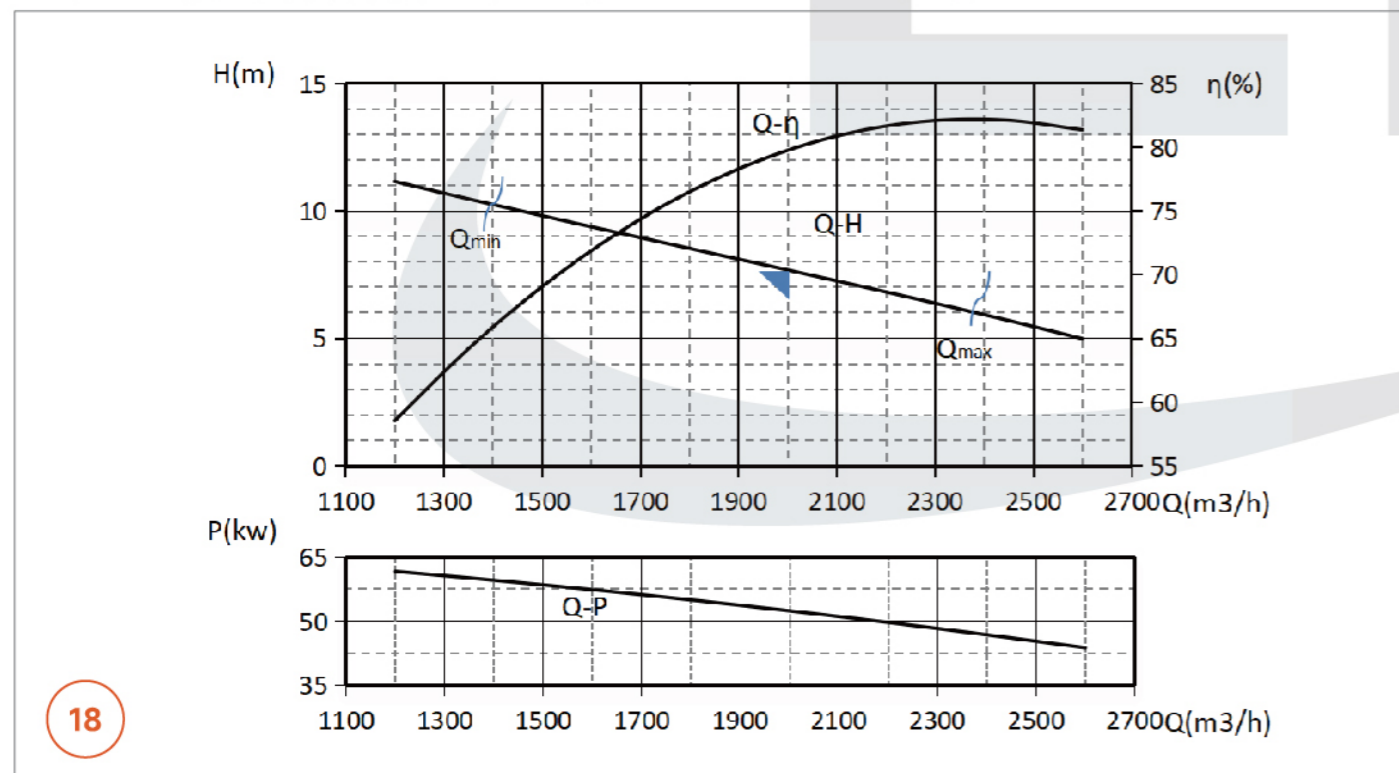

18

500QHD-10 型潜水混流泵性能曲线图 500QHD-10 type submersible Mixed-flow pump performance curve

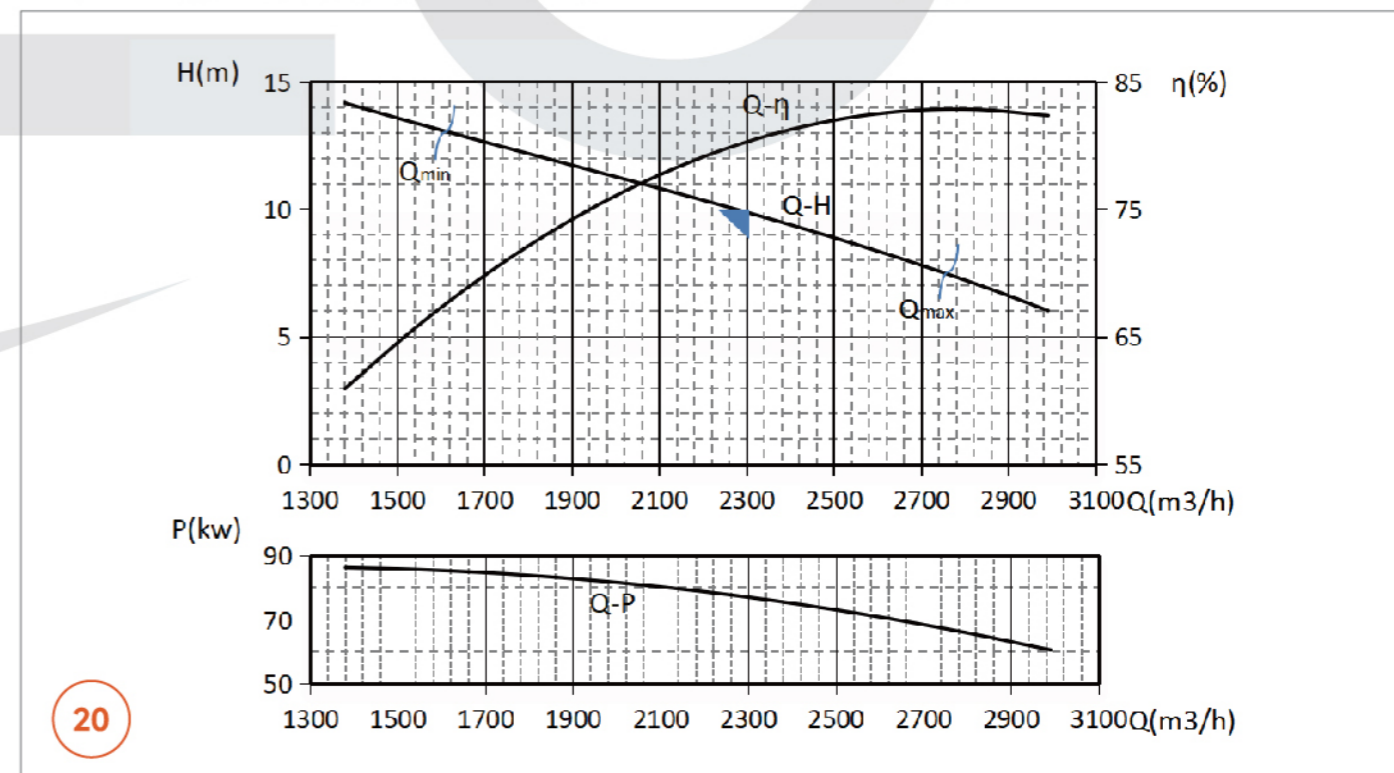

20

性能曲线图 / Performance curve

500QHD-11 型潜水混流泵性能曲线图 500QHD-11 type submersible Mixed-flow pump performance curve

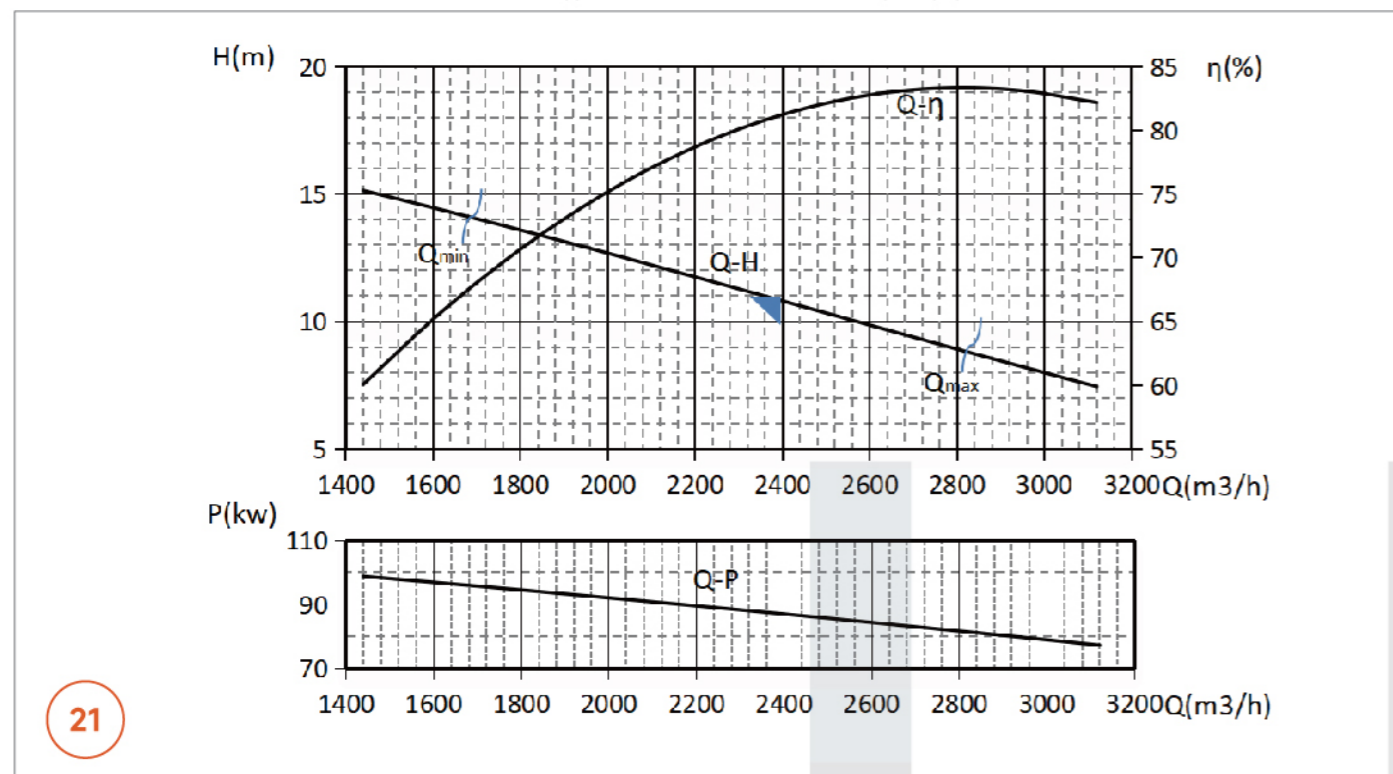

21

性能曲线图 / Performance curve

500QHD-14 型潜水混流泵性能曲线图 500QHD-14 type submersible Mixed-flow pump performance curve

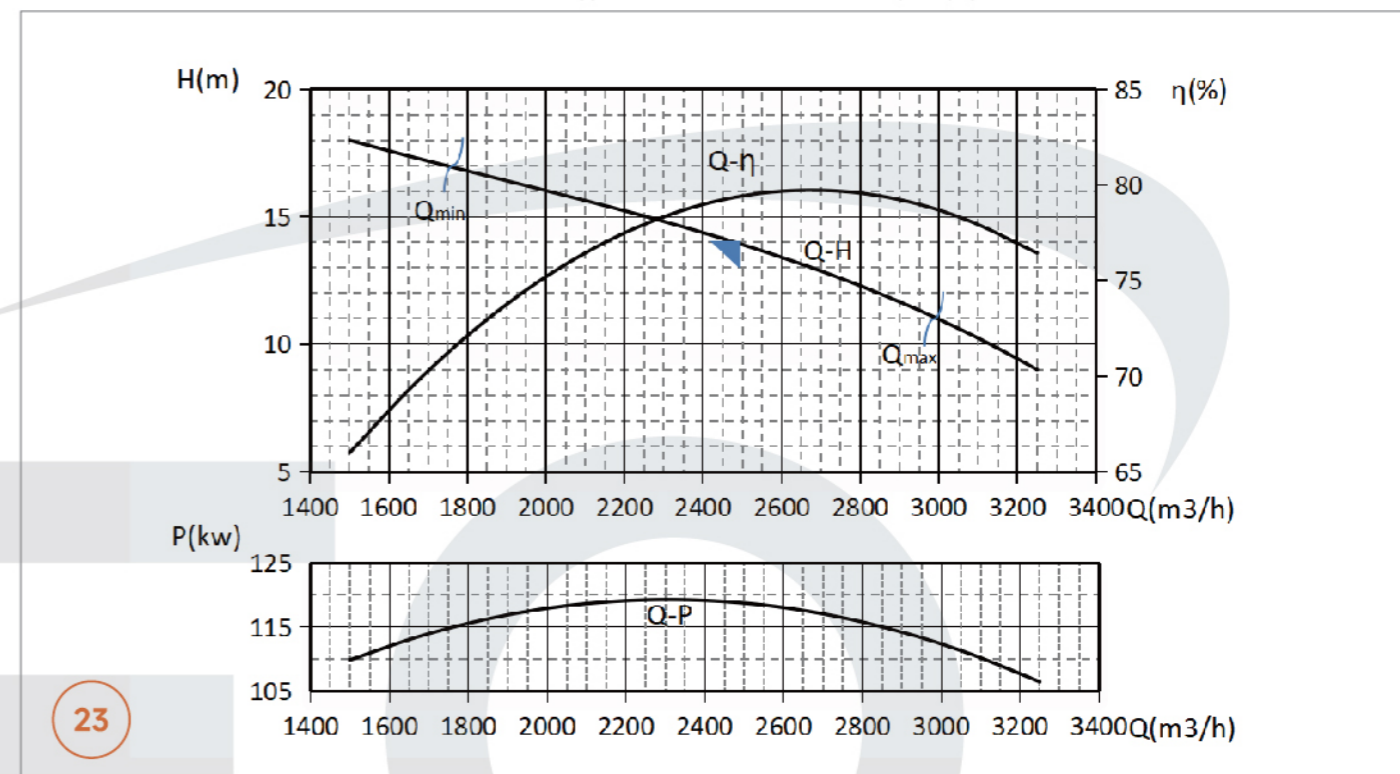

23

500QHD-12 型潜水混流泵性能曲线图 500QHD-12 type submersible Mixed-flow pump performance curve

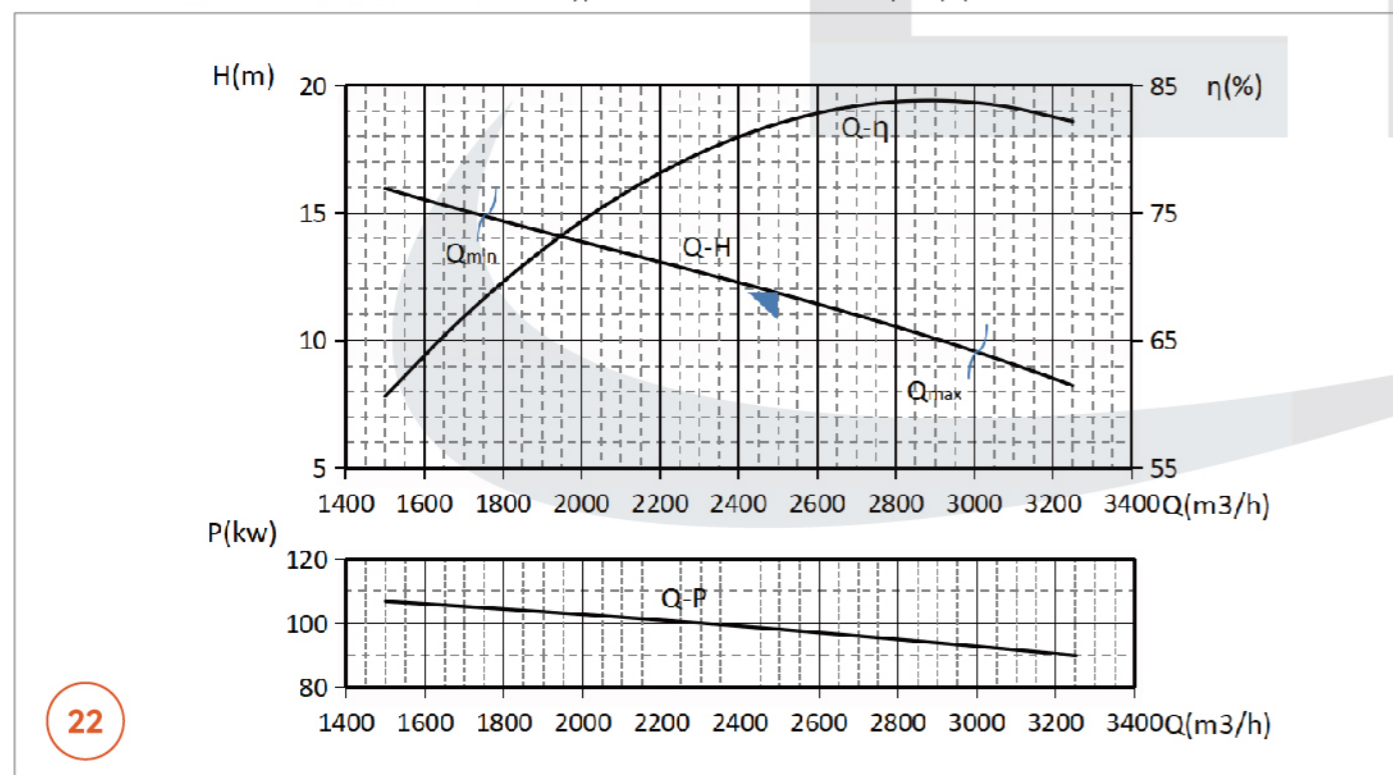

22

500QHD-16 型潜水混流泵性能曲线图 500QHD-16 type submersible Mixed-flow pump performance curve

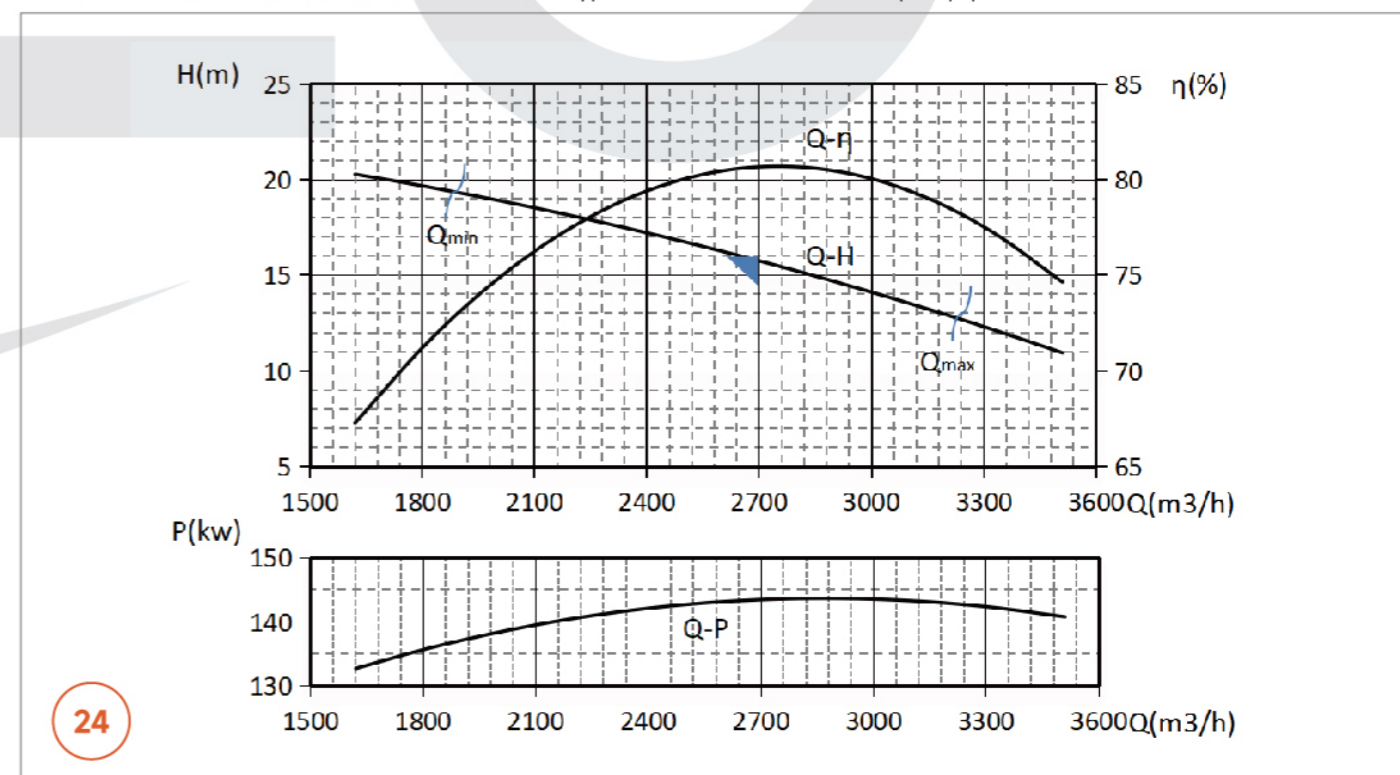

24

性能曲线图 / Performance curve

500QHD-18 型潜水混流泵性能曲线图 500QHD-18 type submersible Mixed-flow pump performance curve

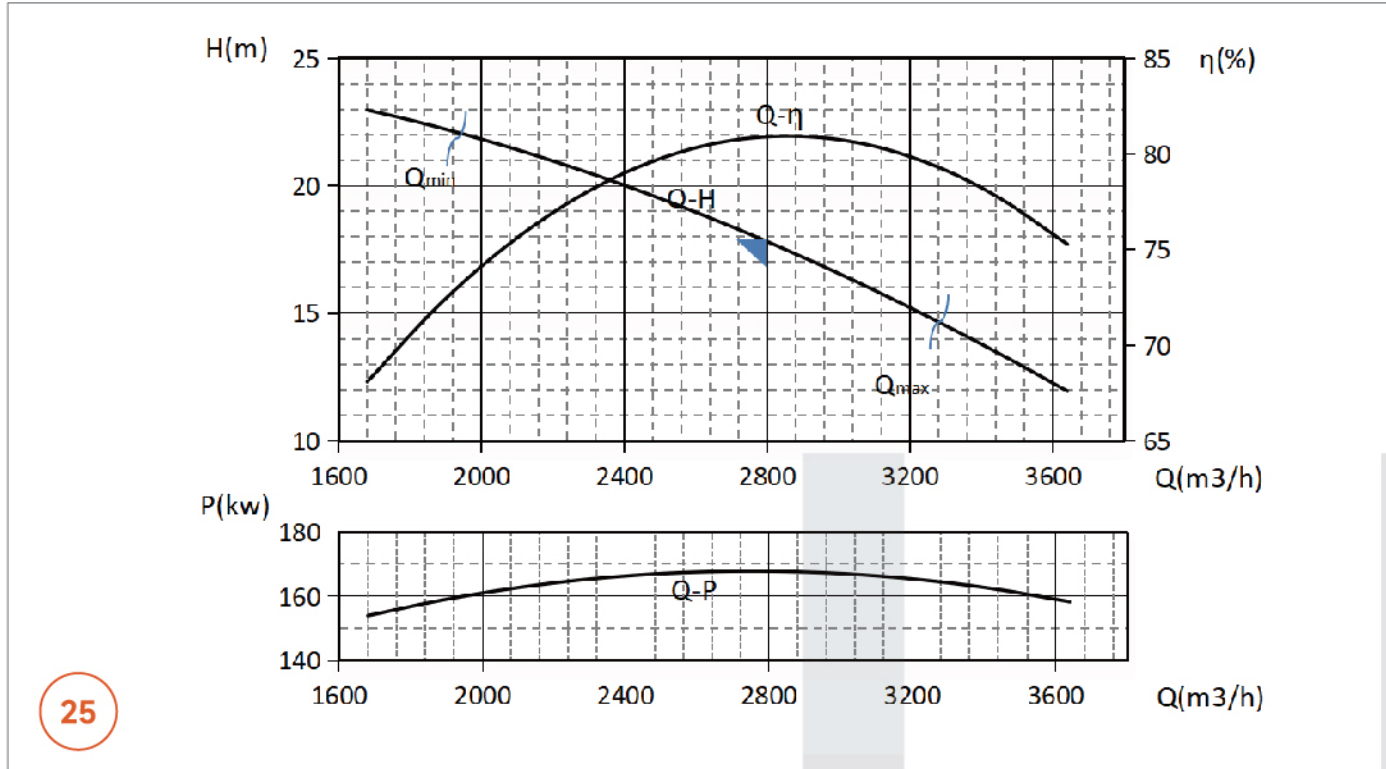

25

性能曲线图 / Performance curve

500QHD-21 型潜水混流泵性能曲线图 500QHD-21 type submersible Mixed-flow pump performance curve

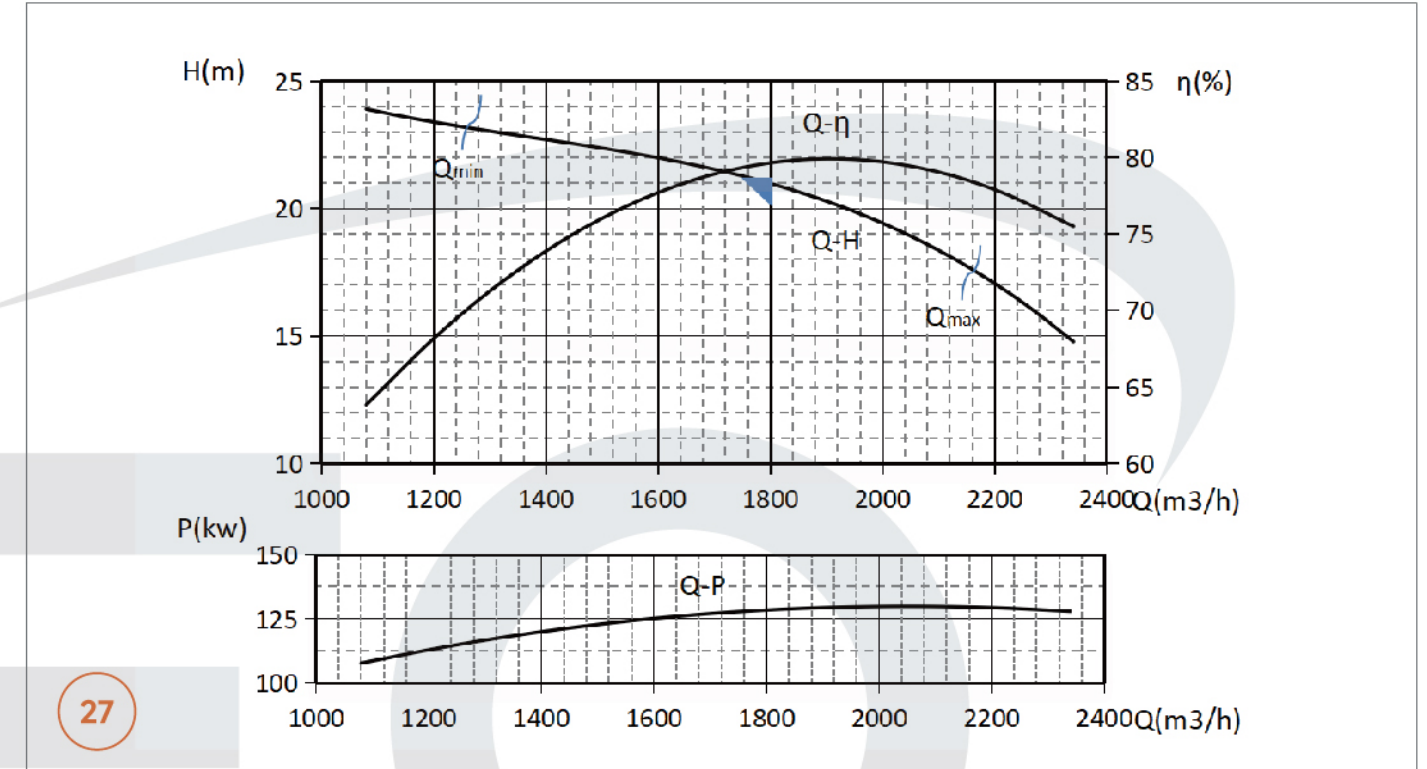

27

500QHD-20 型潜水混流泵性能曲线图 500QHD-20 type submersible Mixed-flow pump performance curve

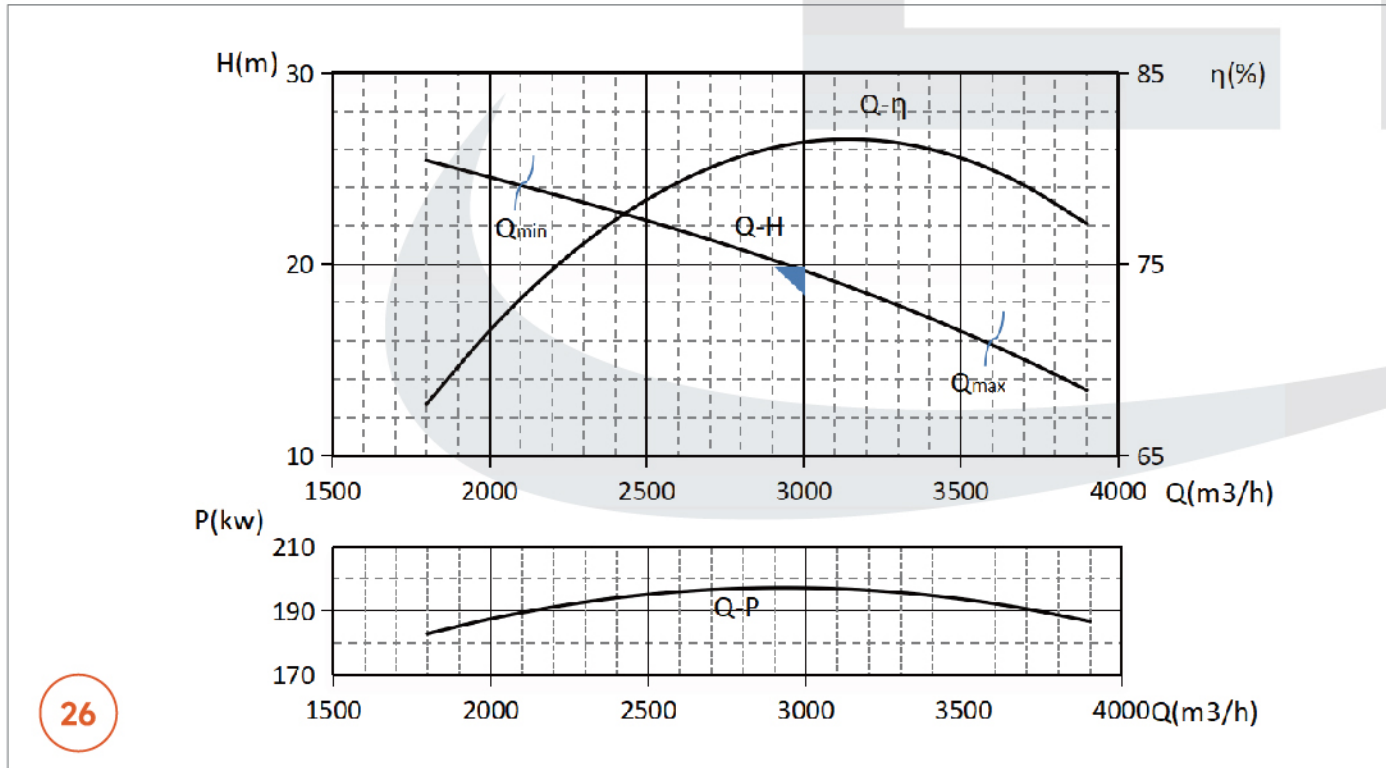

26

500QHD-20.5 型潜水混流泵性能曲线图 500QHD-20.5 type submersible Mixed-flow pump performance curve

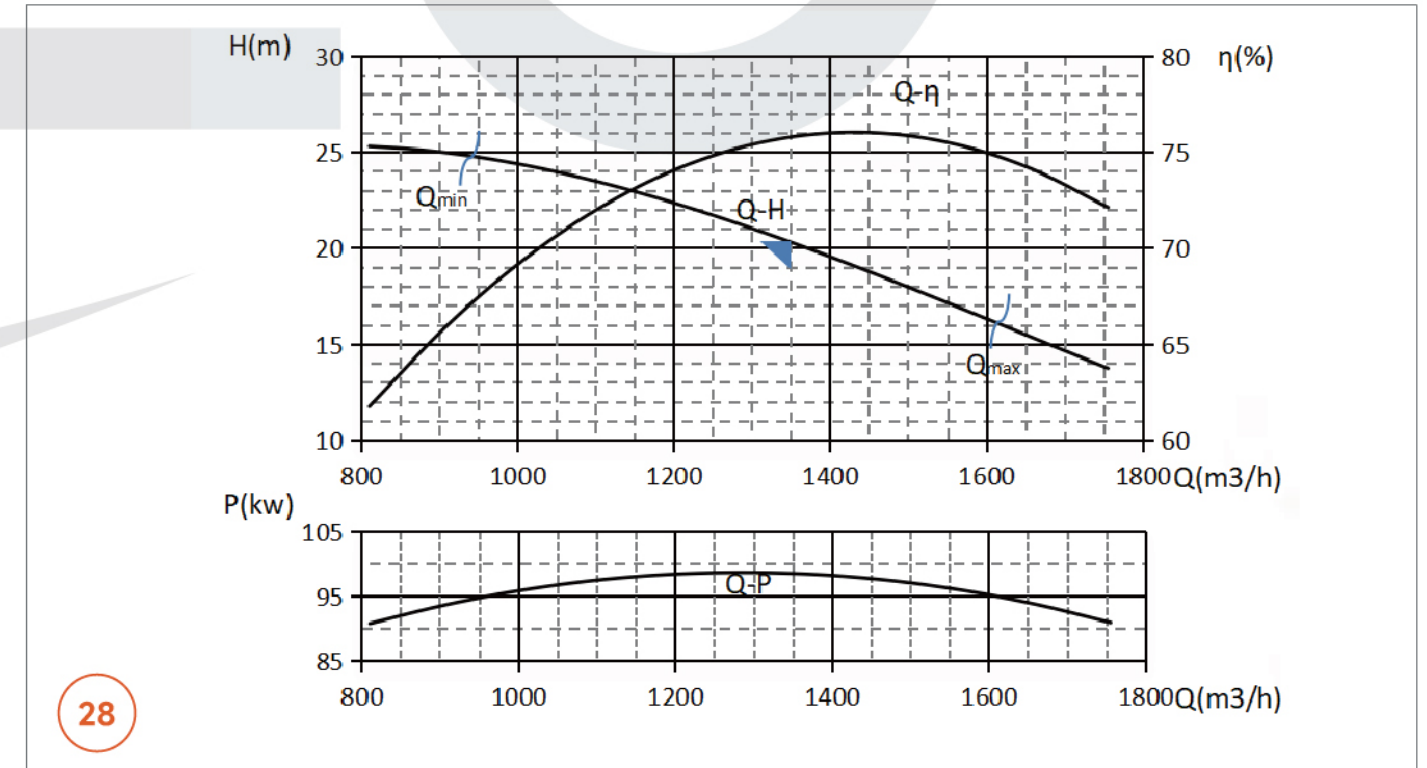

28

性能曲线图 / Performance curve

500QHD-22 型潜水混流泵性能曲线图 500QHD-22 type submersible Mixed-flow pump performance curve

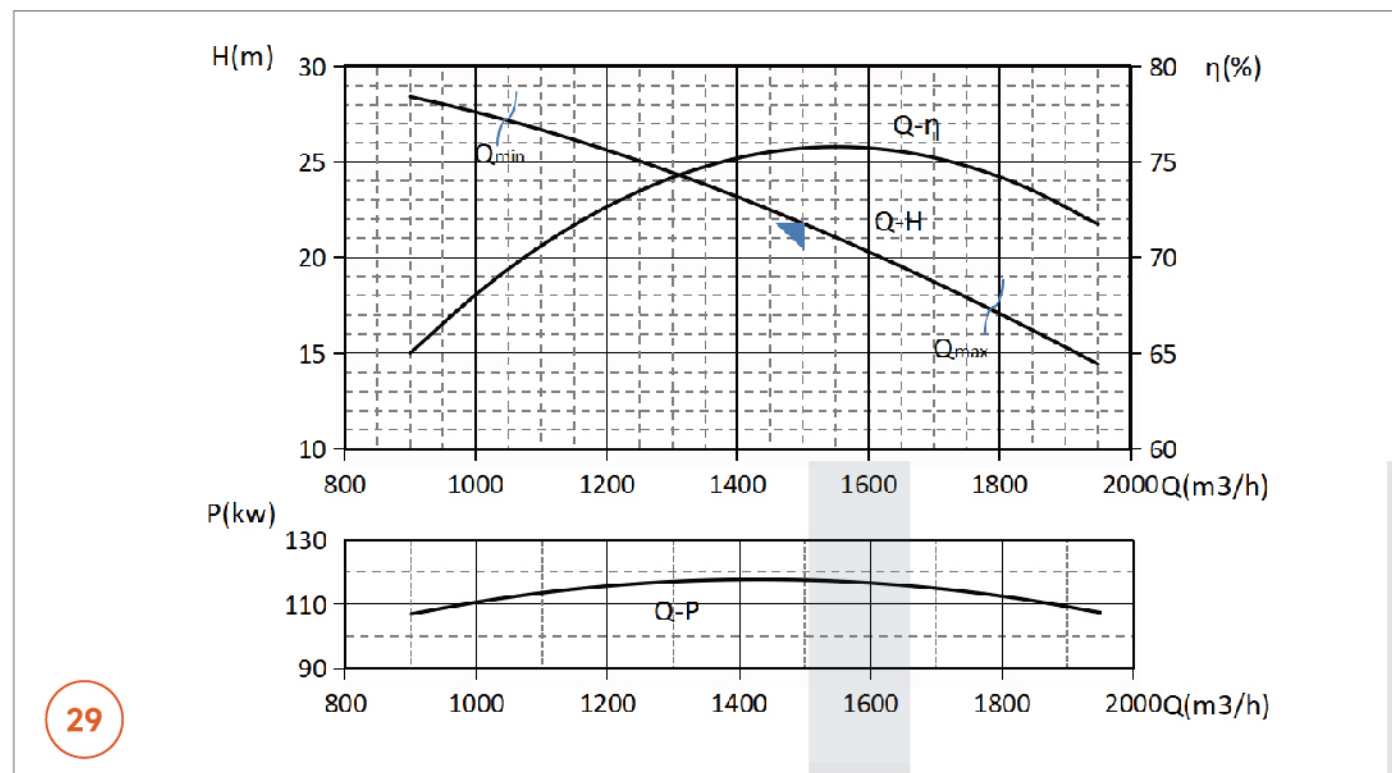

29

性能曲线图 / Performance curve

500QHD-30 型潜水混流泵性能曲线图 500QHD-30 type submersible Mixed-flow pump performance curve

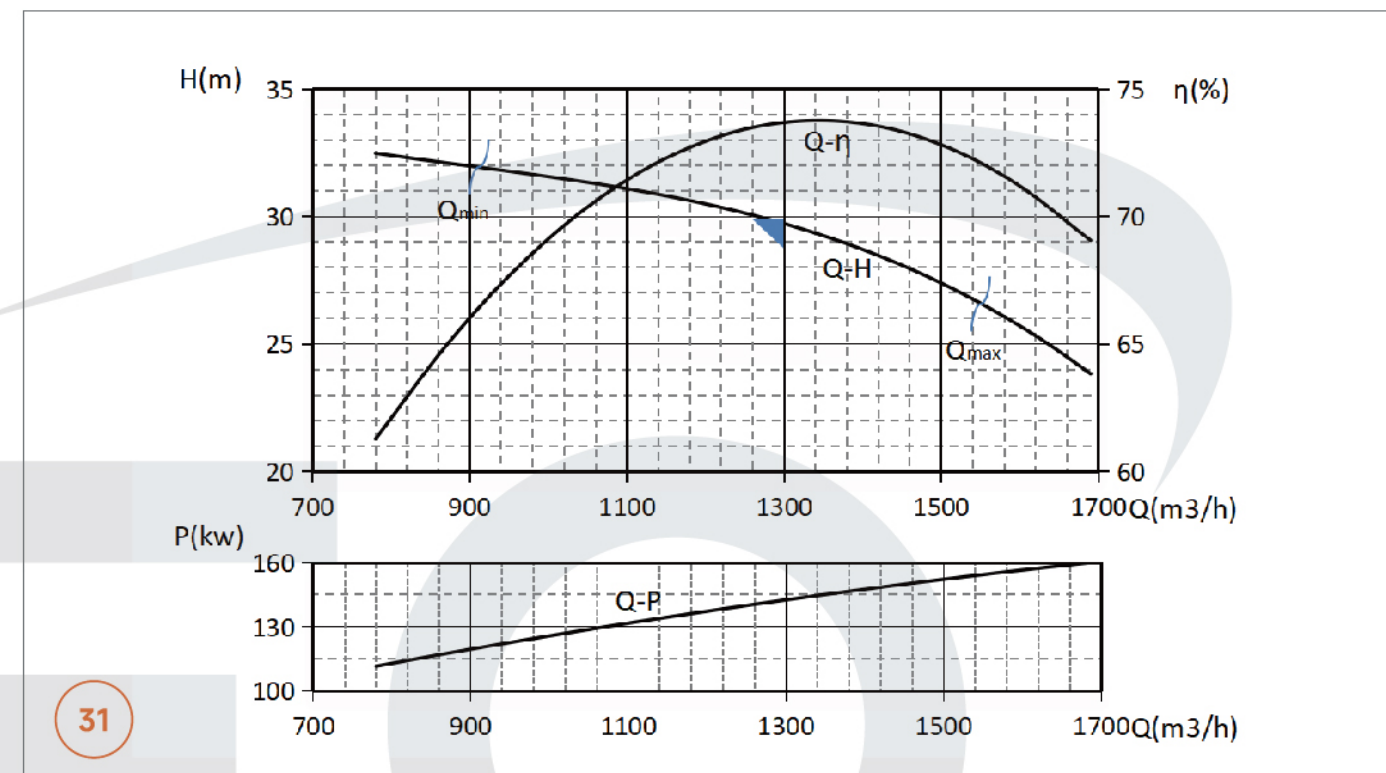

31

500QHD-25 型潜水混流泵性能曲线图 500QHD-25 type submersible Mixed-flow pump performance curve

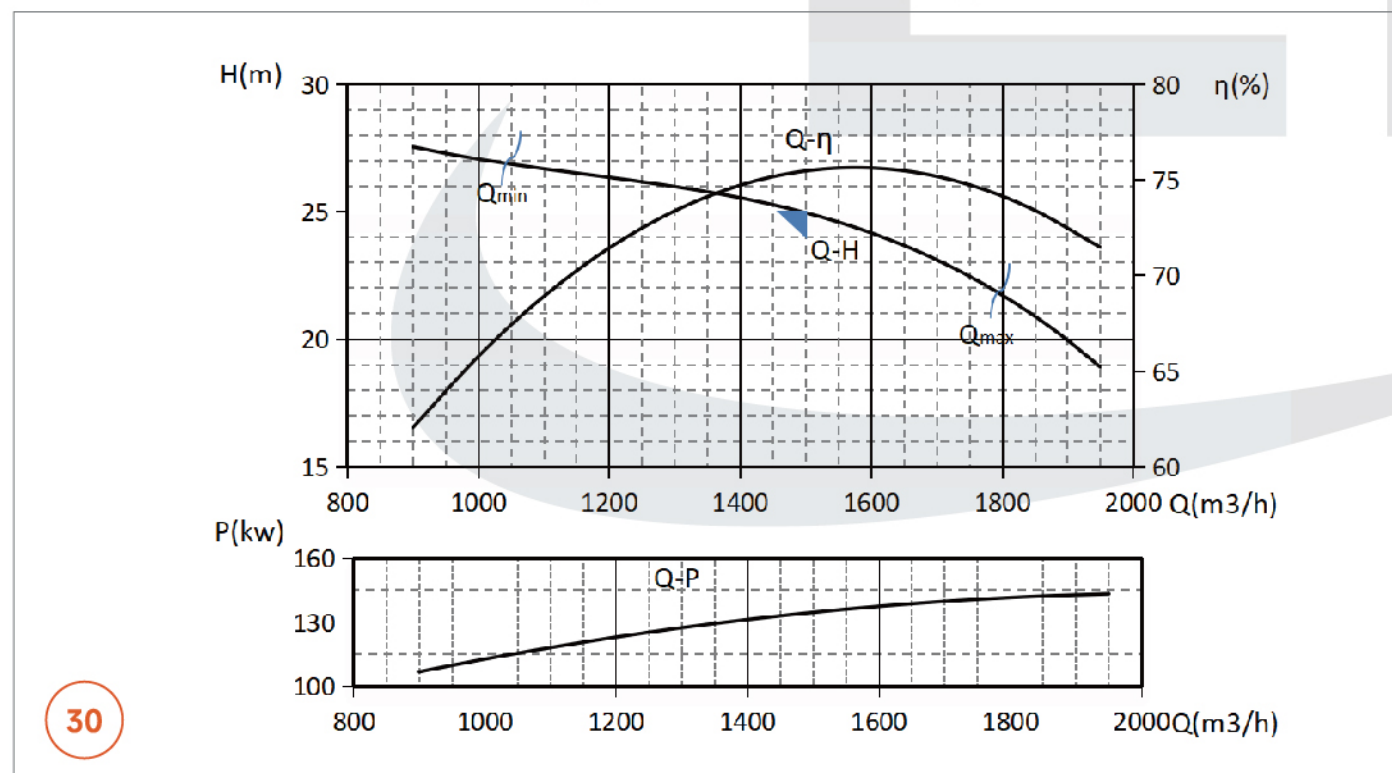

30

500QHD-34 型潜水混流泵性能曲线图 500QHD-34 type submersible Mixed-flow pump performance curve

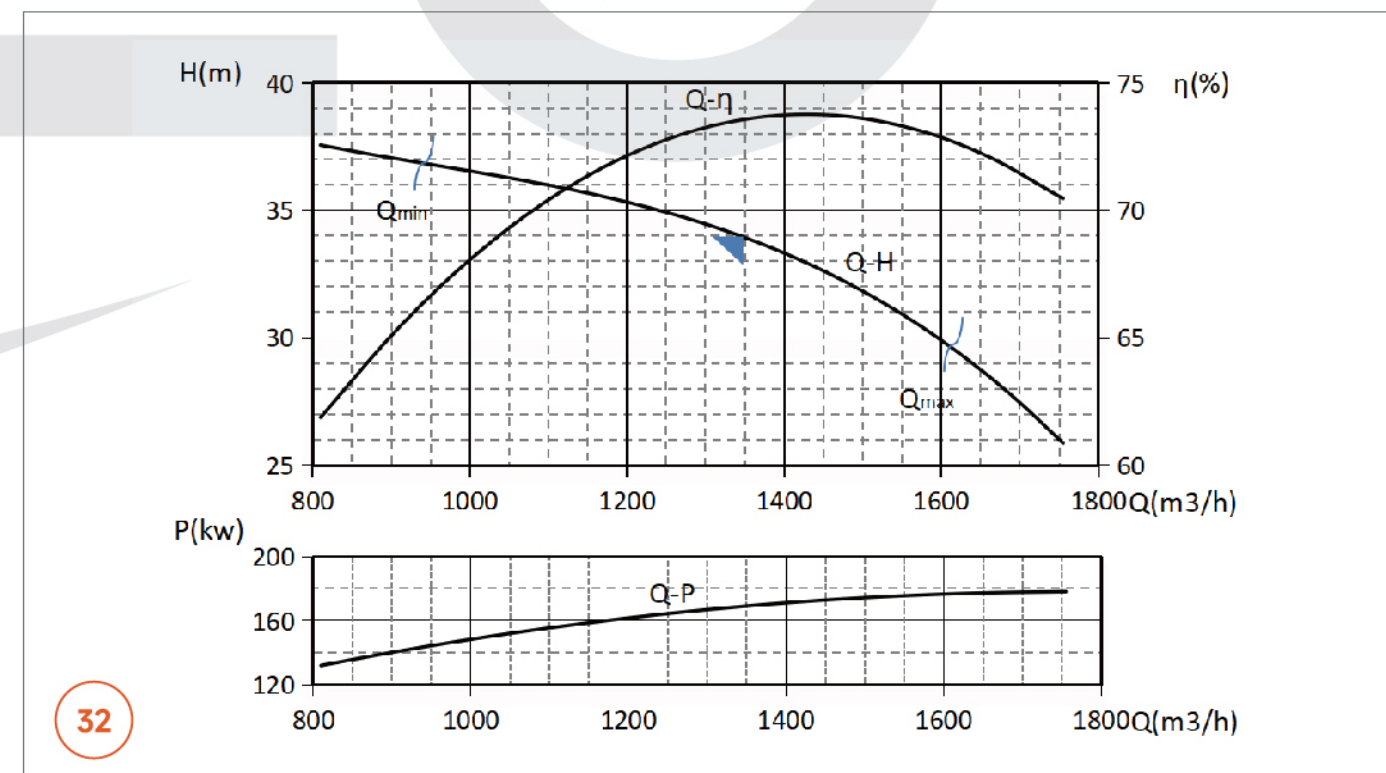

32

性能曲线图 / Performance curve

500QHD-38 型潜水混流泵性能曲线图 500QHD-38 type submersible Mixed-flow pump performance curve

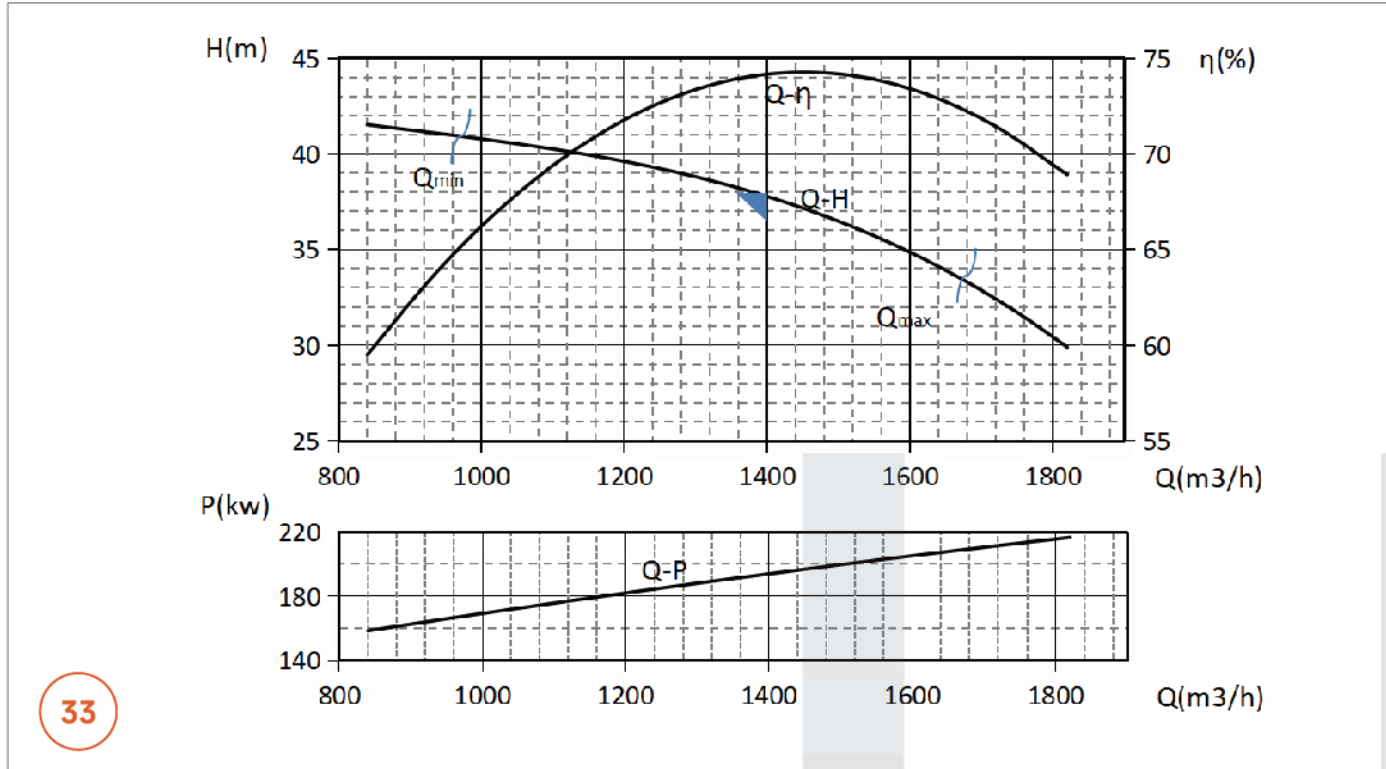

33

性能曲线图 / Performance curve

600HD-10 型潜水混流泵性能曲线图 600HD-10 type submersible Mixed-flow pump performance curve

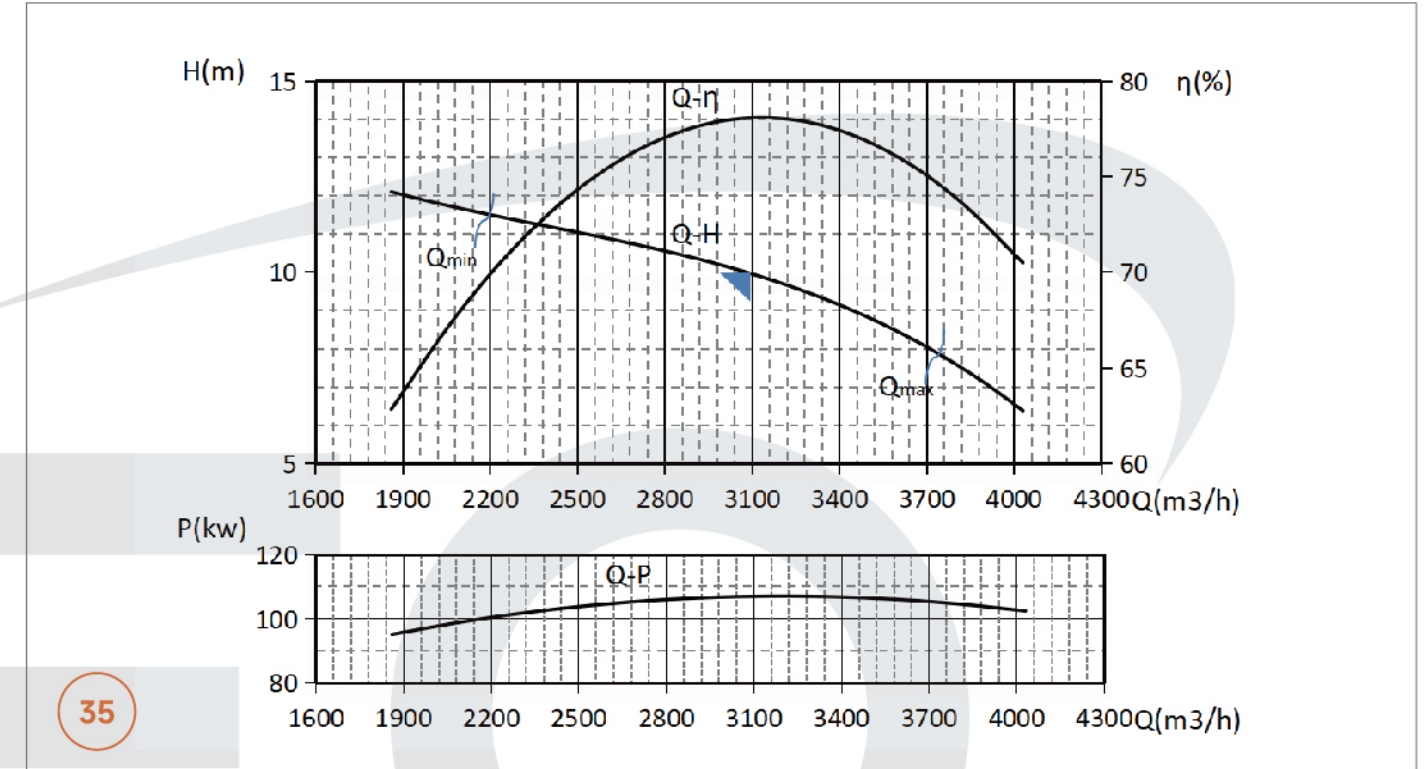

35

500QHD-42 型潜水混流泵性能曲线图 500QHD-42 type submersible Mixed-flow pump performance curve

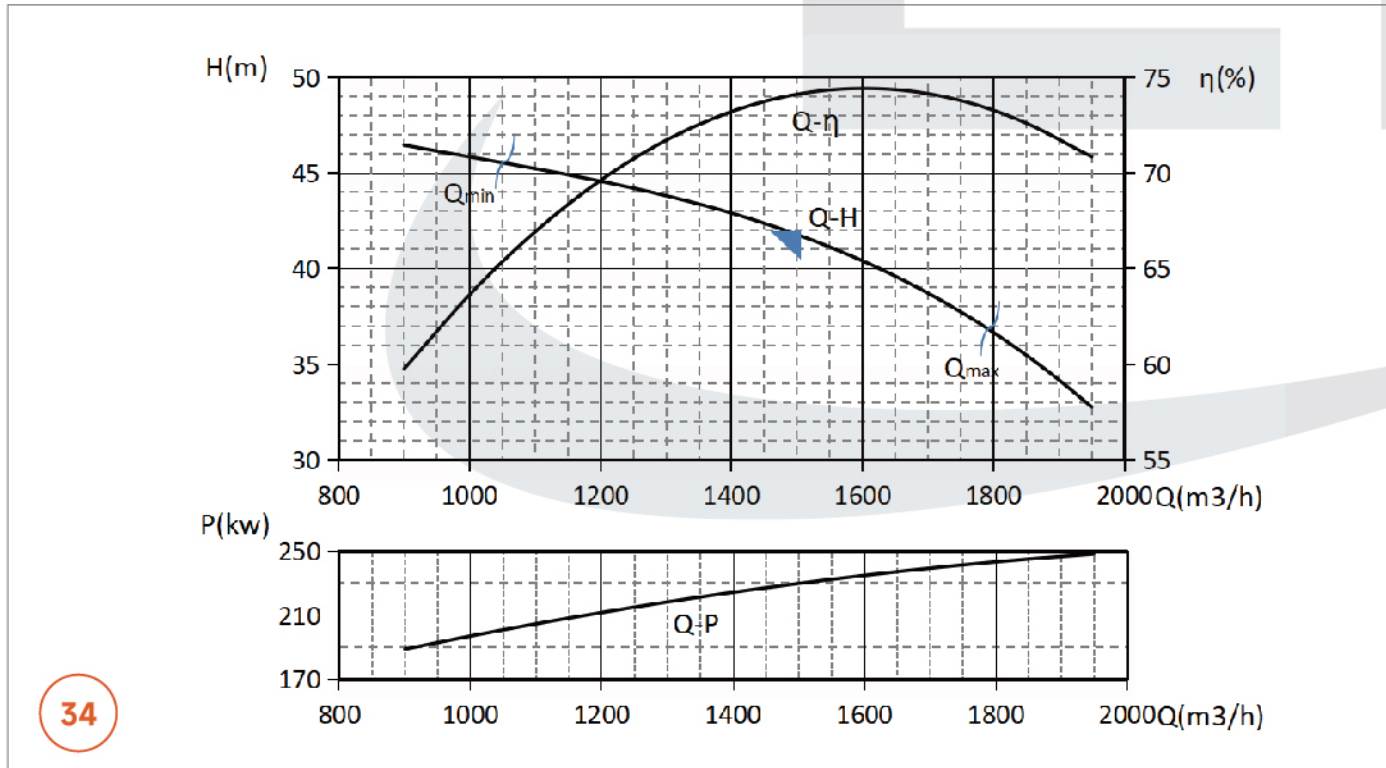

34

600QHD-12 型潜水混流泵性能曲线图 600QHD-12 type submersible Mixed-flow pump performance curve

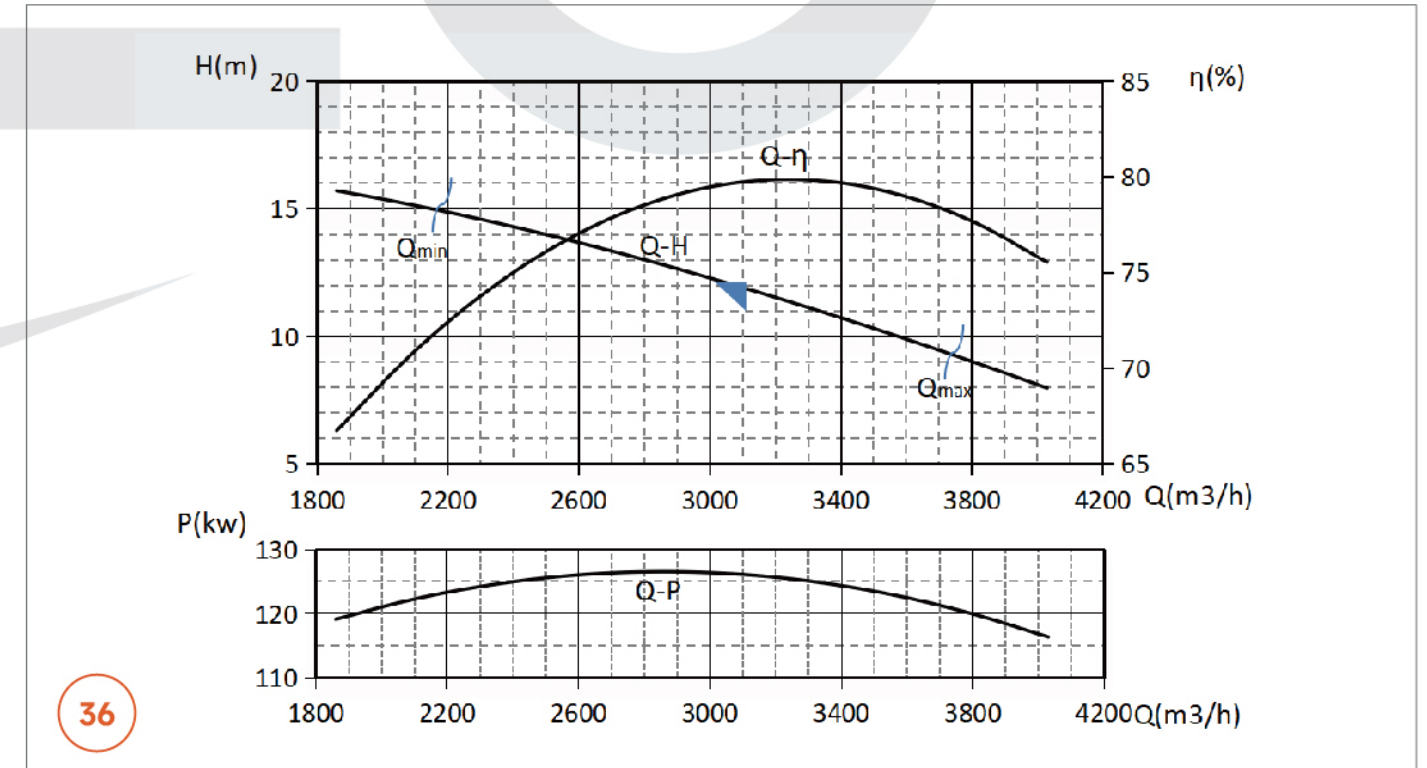

36

性能曲线图 / Performance curve

600QHD-14 型潜水混流泵性能曲线图 600QHD-14 type submersible Mixed-flow pump performance curve

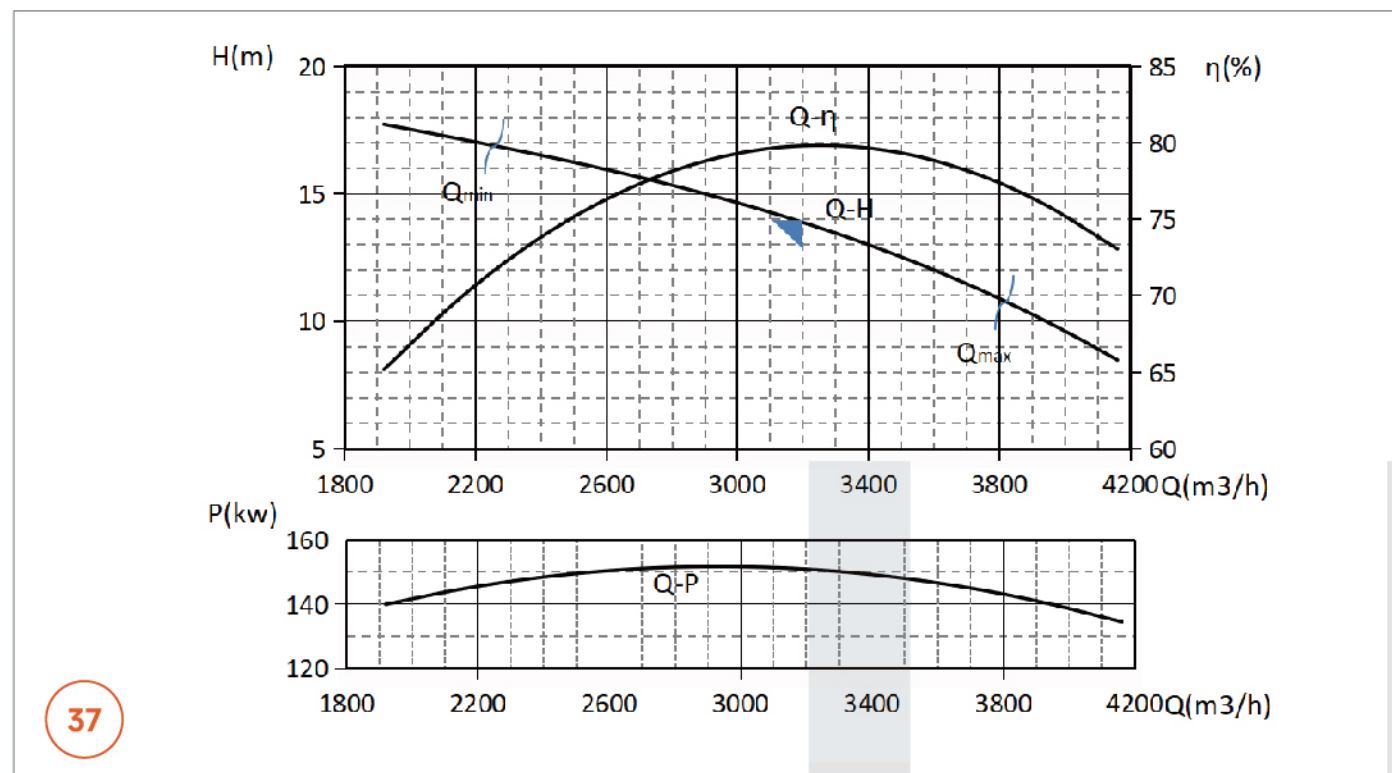

37

性能曲线图 / Performance curve

600QHD-18 型潜水混流泵性能曲线图 600QHD-18 type submersible Mixed-flow pump performance curve

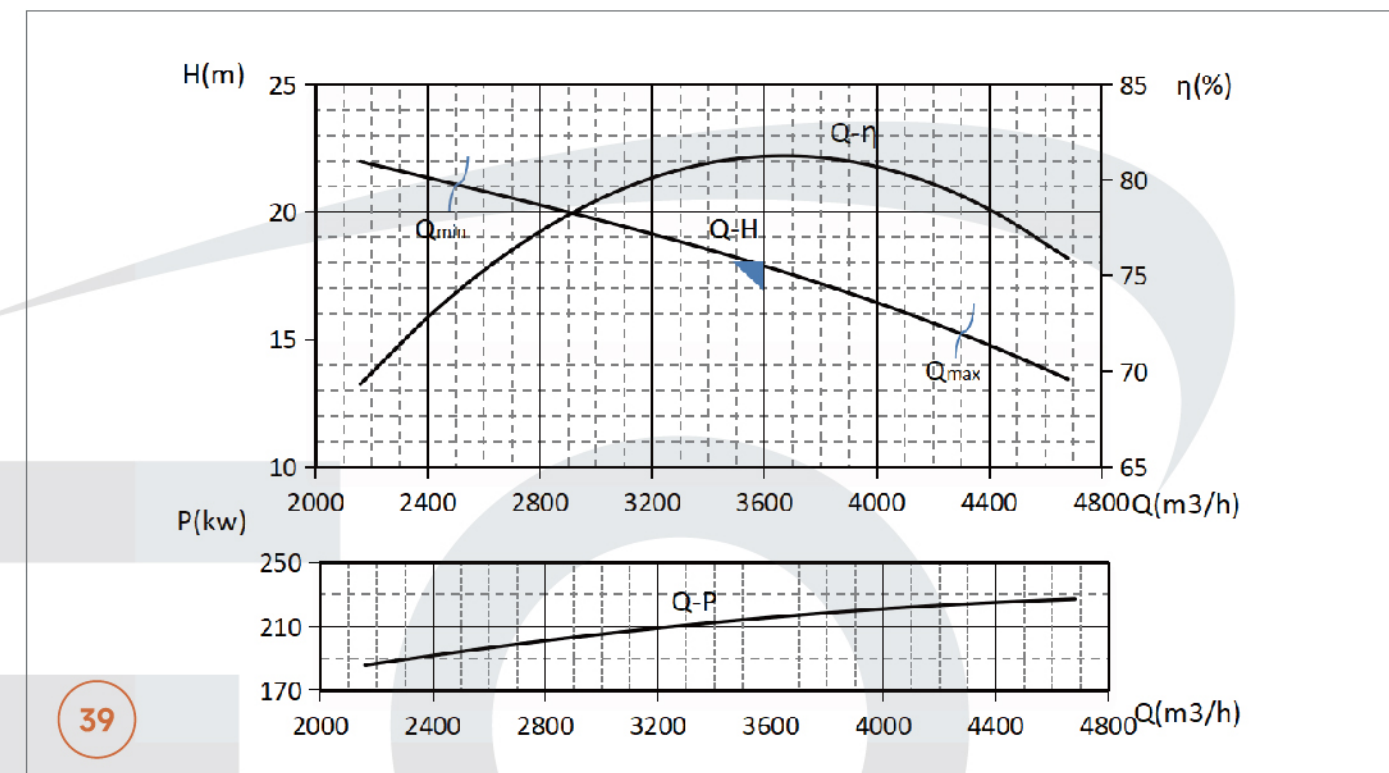

39

600QHD-16 型潜水混流泵性能曲线图 600QHD-16 type submersible Mixed-flow pump performance curve

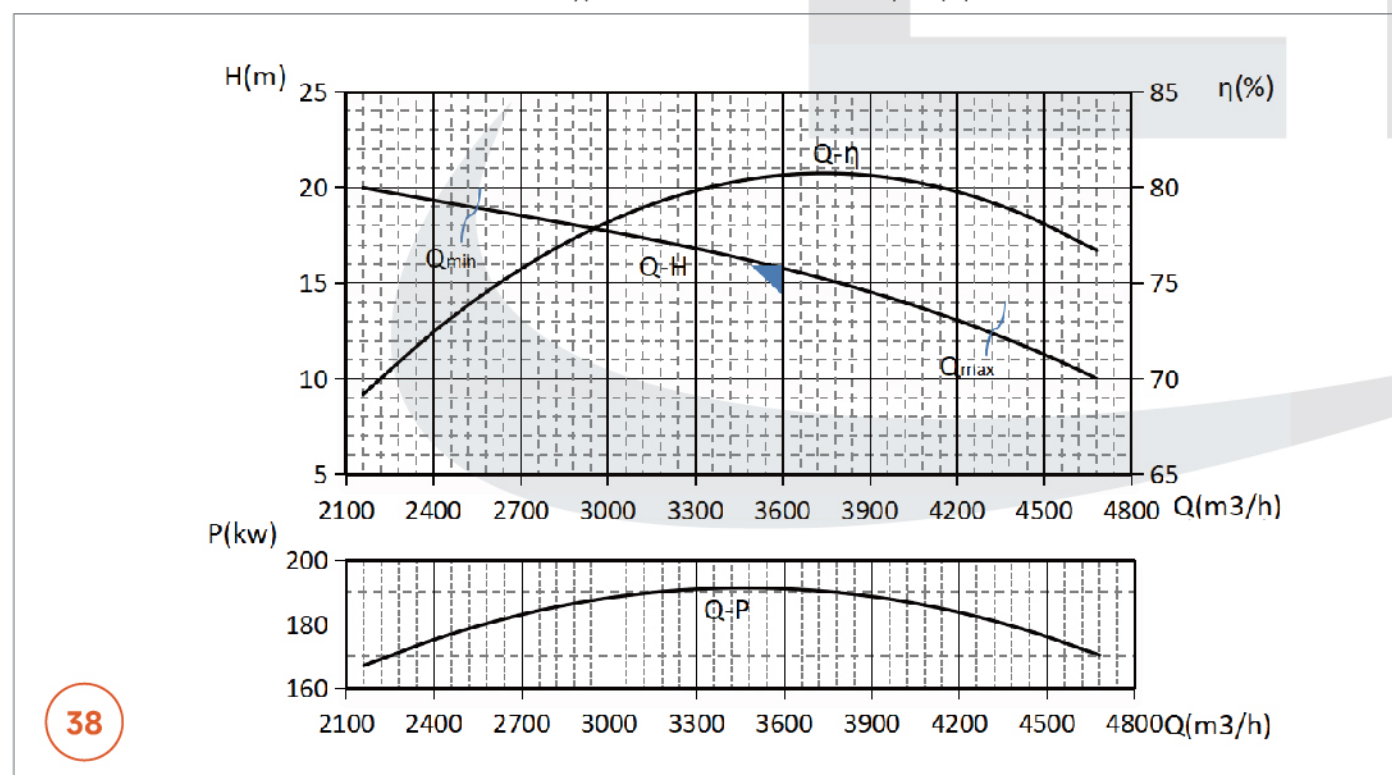

38

600QHD-15 型潜水混流泵性能曲线图 600QHD-15 type submersible Mixed-flow pump performance curve

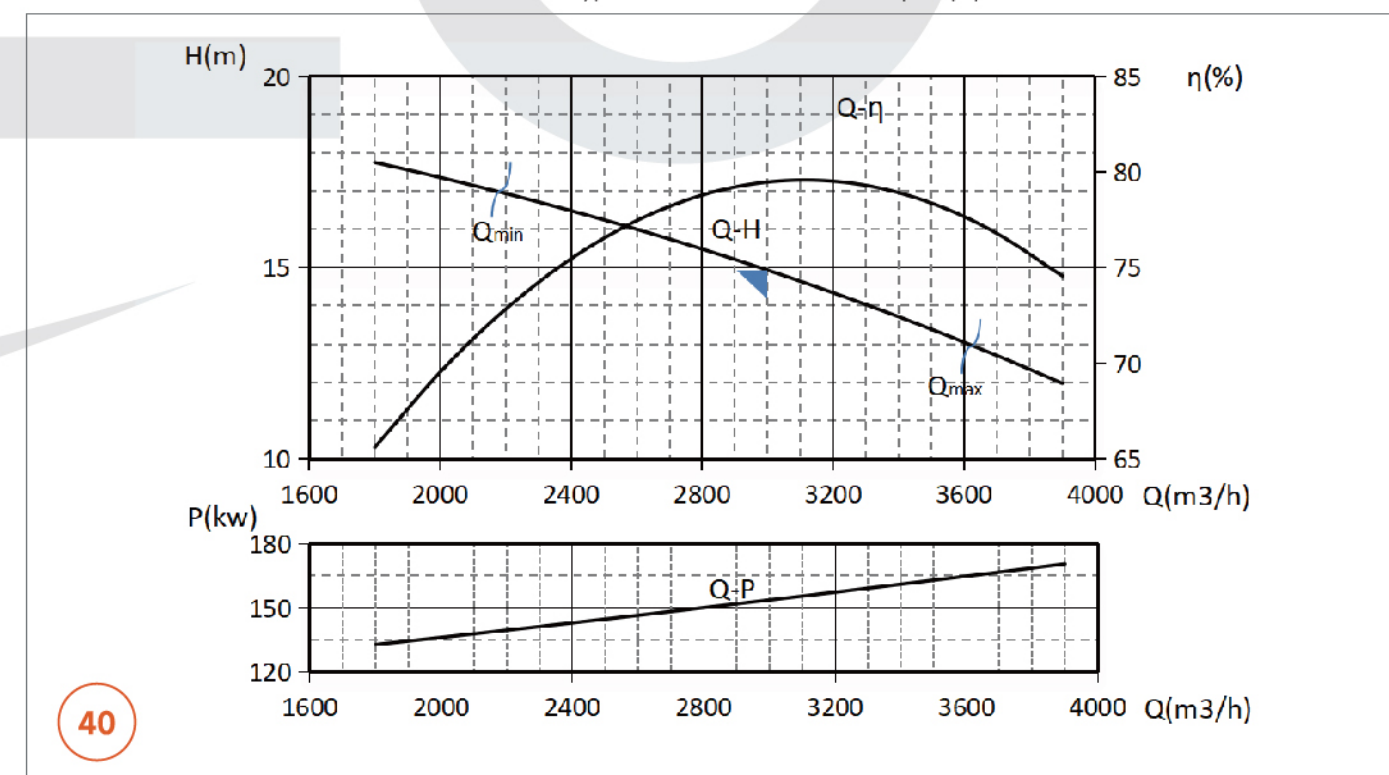

40

性能曲线图 / Performance curve

600QHD-17 型潜水混流泵性能曲线图 600QHD-17 type submersible Mixed-flow pump performance curve

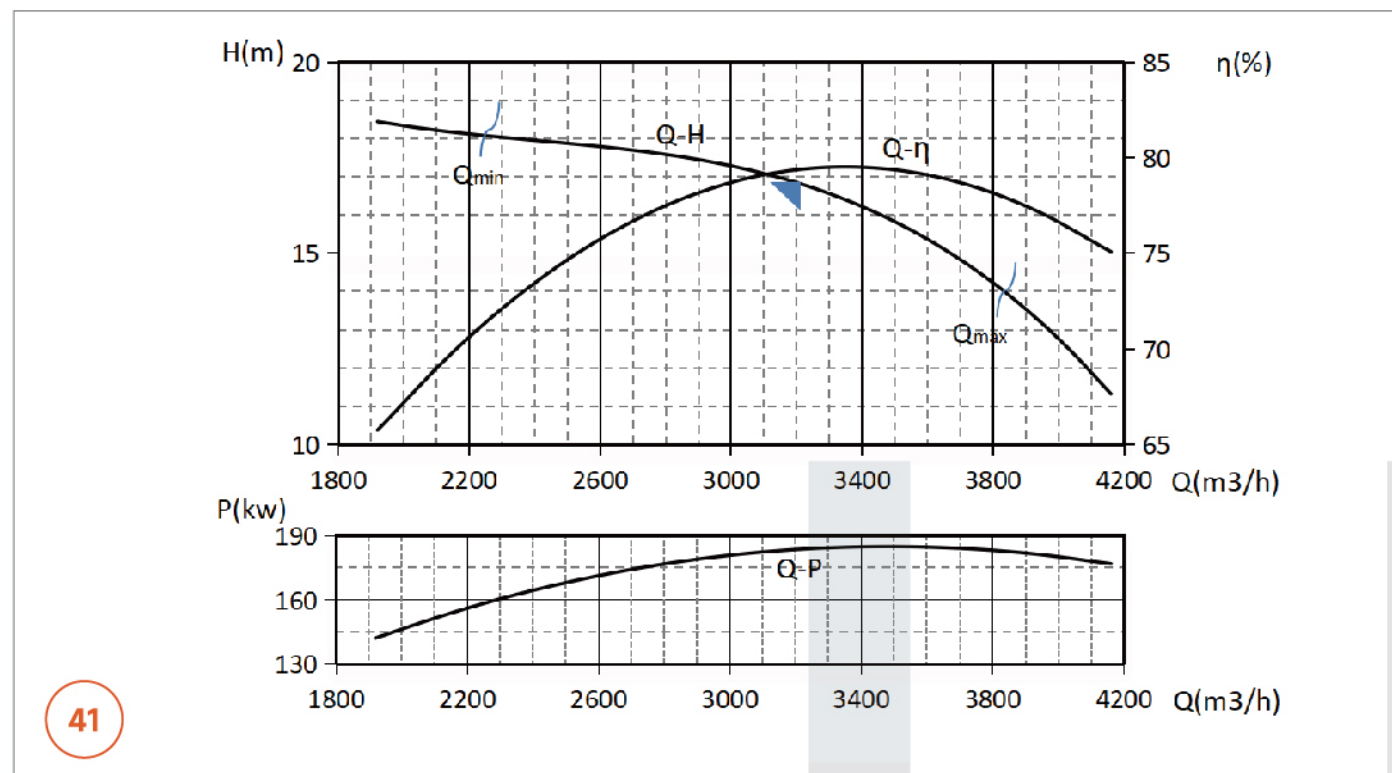

41

性能曲线图 / Performance curve

600QHD-23 型潜水混流泵性能曲线图 600QHD-23 type submersible Mixed-flow pump performance curve

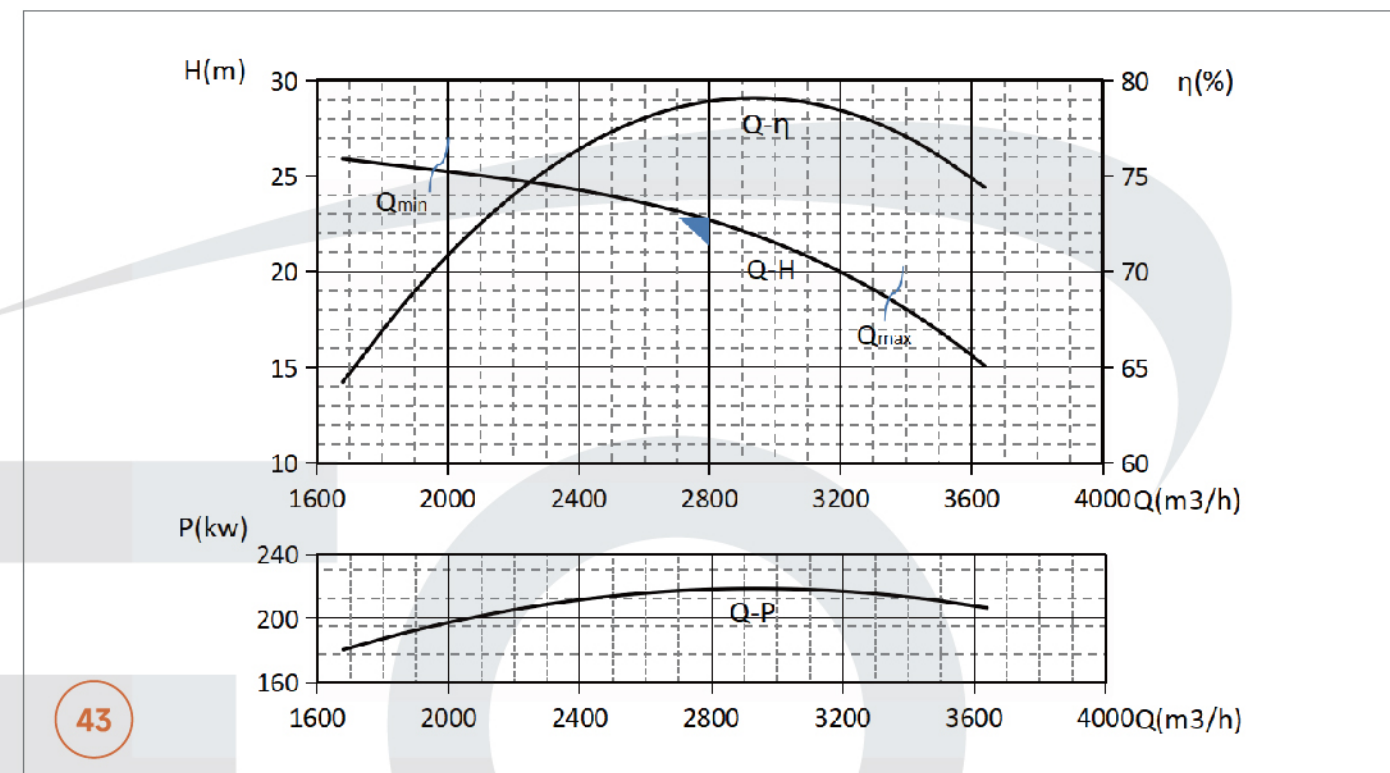

43

600QHD-20 型潜水混流泵性能曲线图 600QHD-20 type submersible Mixed-flow pump performance curve

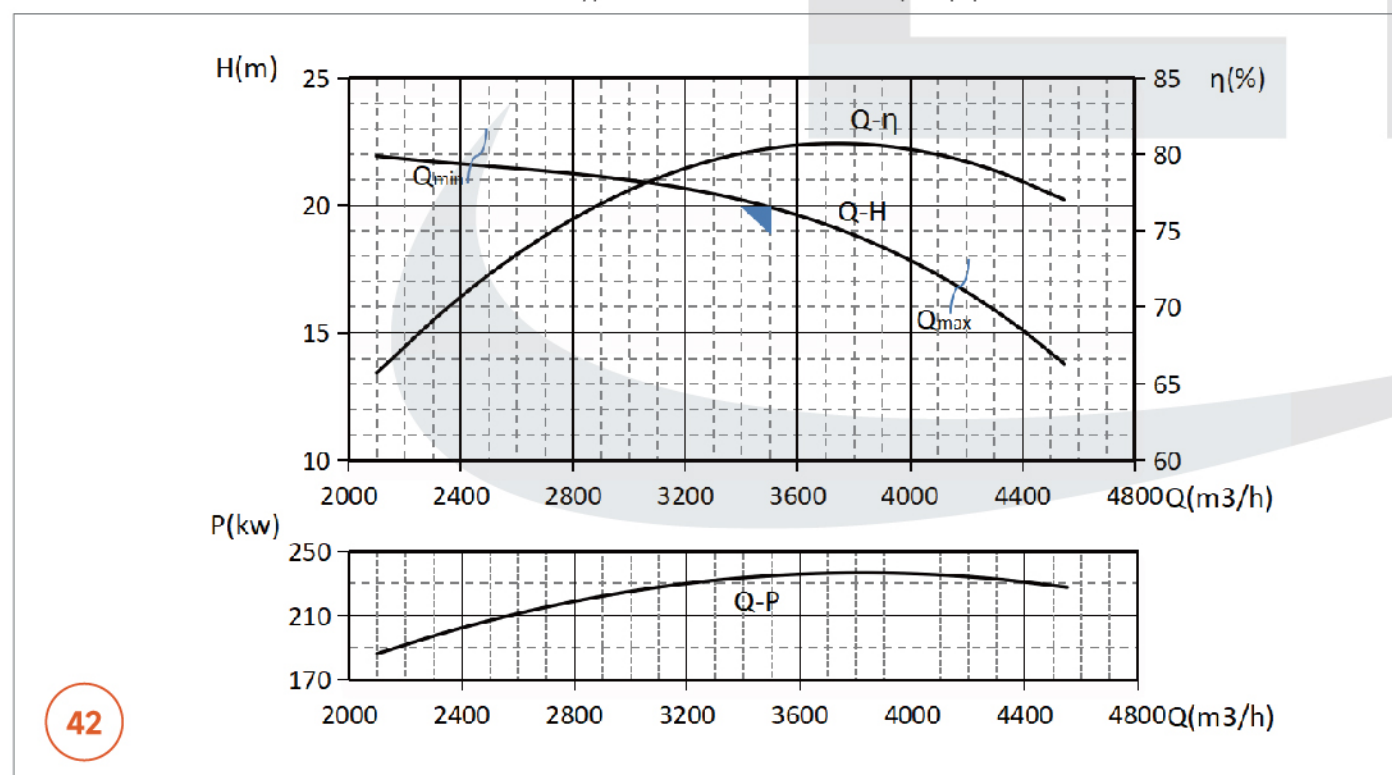

42

600QHD-25 型潜水混流泵性能曲线图 600QHD-25 type submersible Mixed-flow pump performance curve

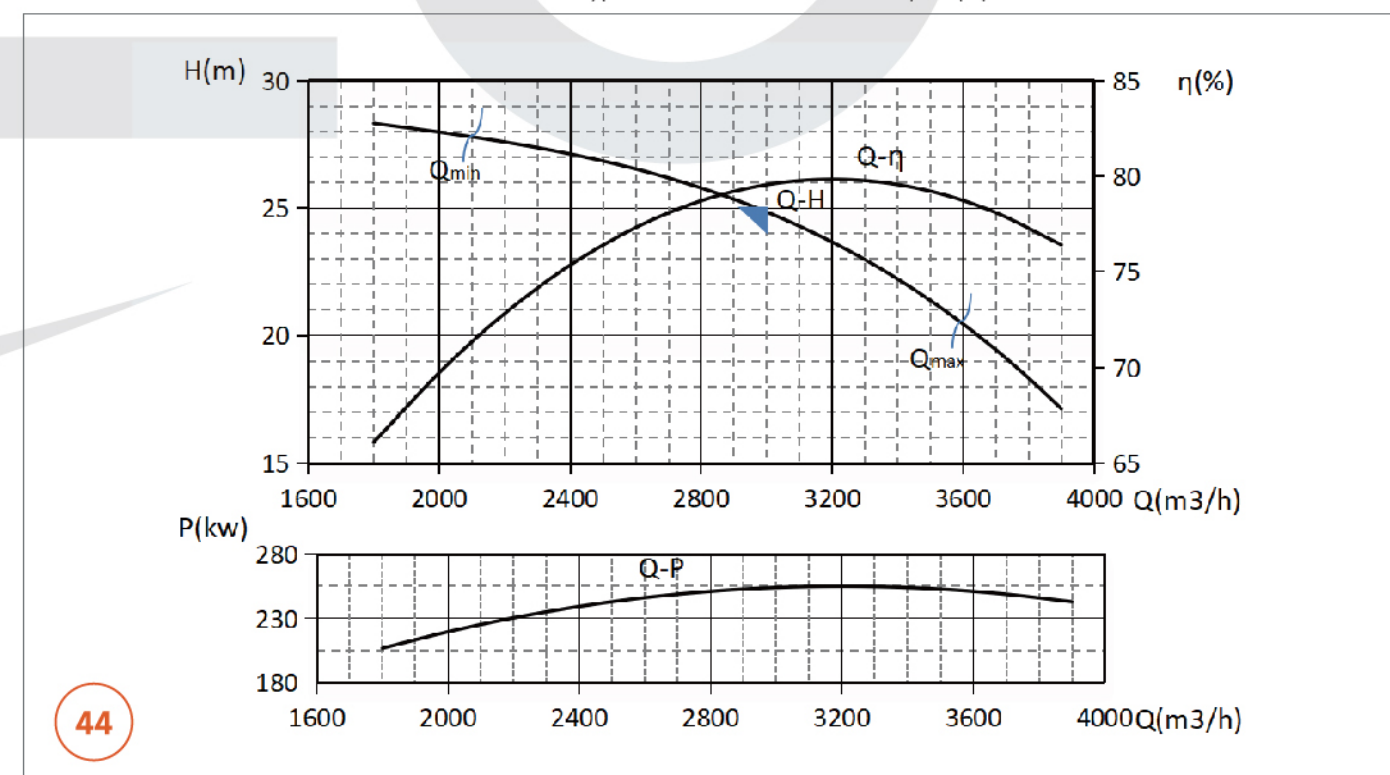

44

性能曲线图 / Performance curve

600QHD-26 型潜水混流泵性能曲线图 600QHD-26 type submersible Mixed-flow pump performance curve

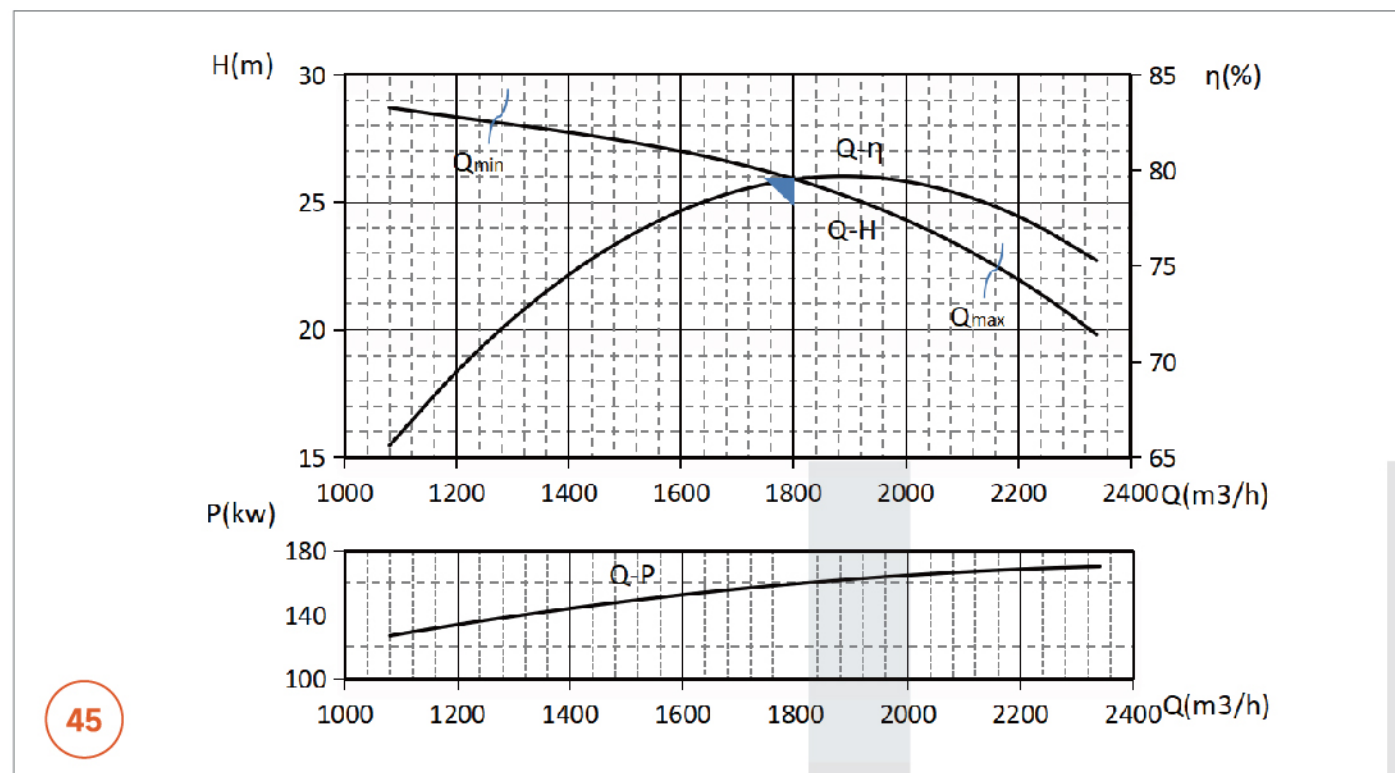

45

性能曲线图 / Performance curve

600QHD-30 型潜水混流泵性能曲线图 600QHD-30 type submersible Mixed-flow pump performance curve

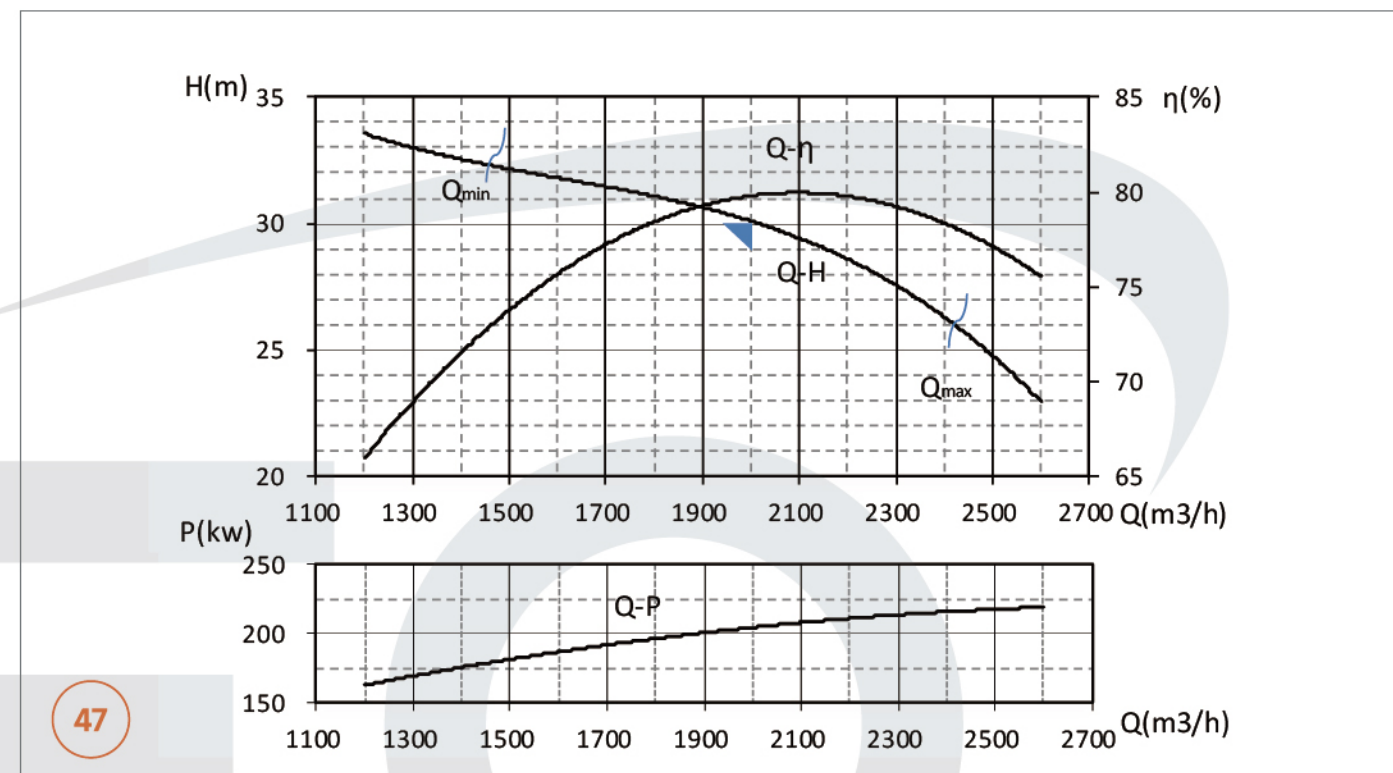

47

600QHD-28 型潜水混流泵性能曲线图 600QHD-28 type submersible Mixed-flow pump performance curve

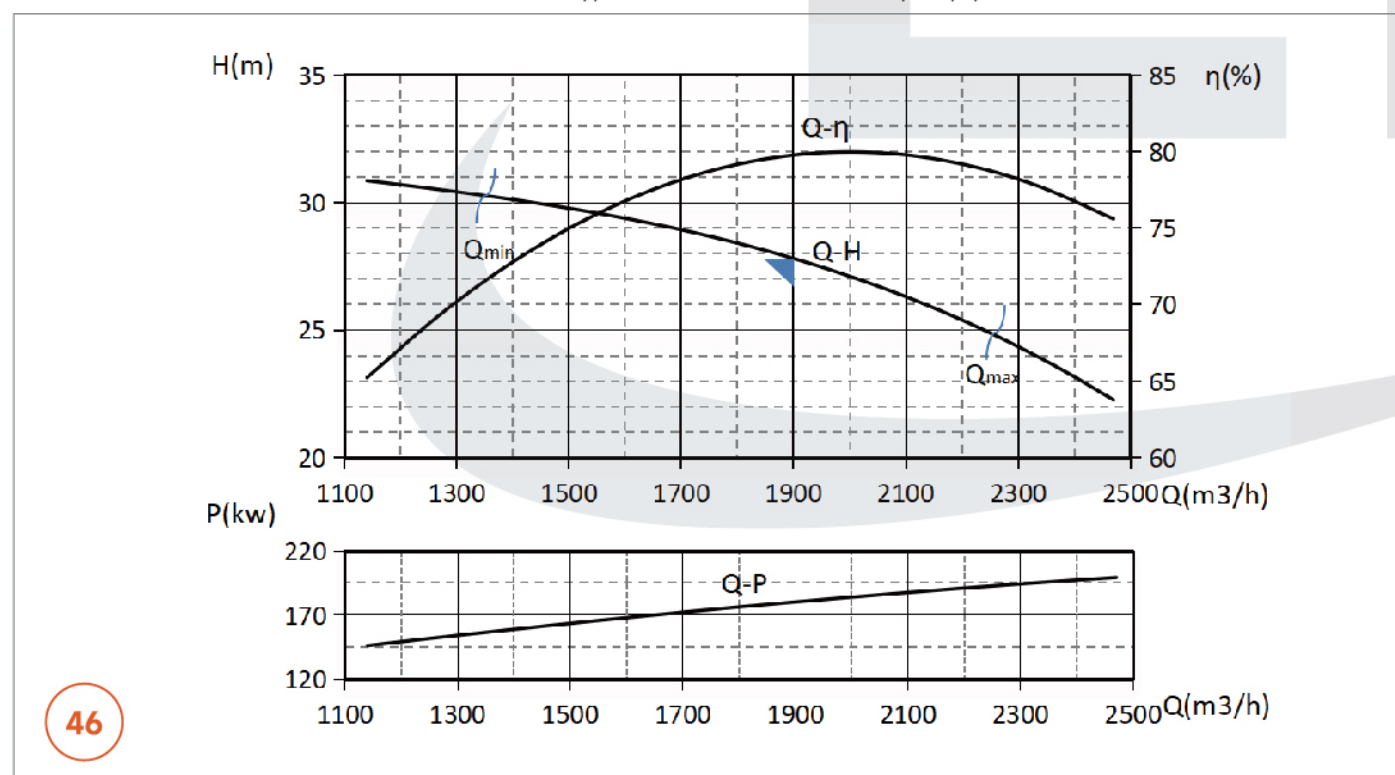

46

600QHD-31 型潜水混流泵性能曲线图 600QHD-31 type submersible Mixed-flow pump performance curve

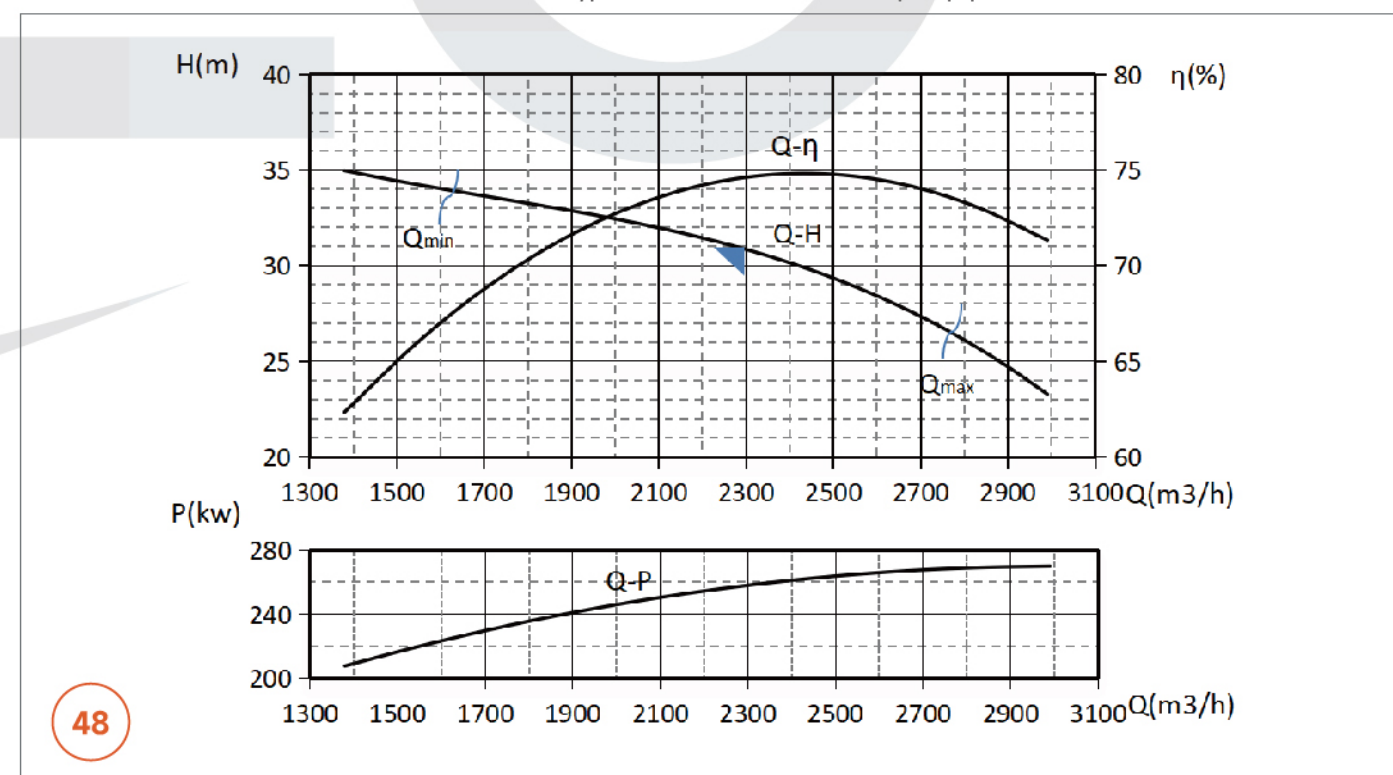

48

性能曲线图 / Performance curve

600QHD-32 型潜水混流泵性能曲线图 600QHD-32 type submersible Mixed-flow pump performance curve

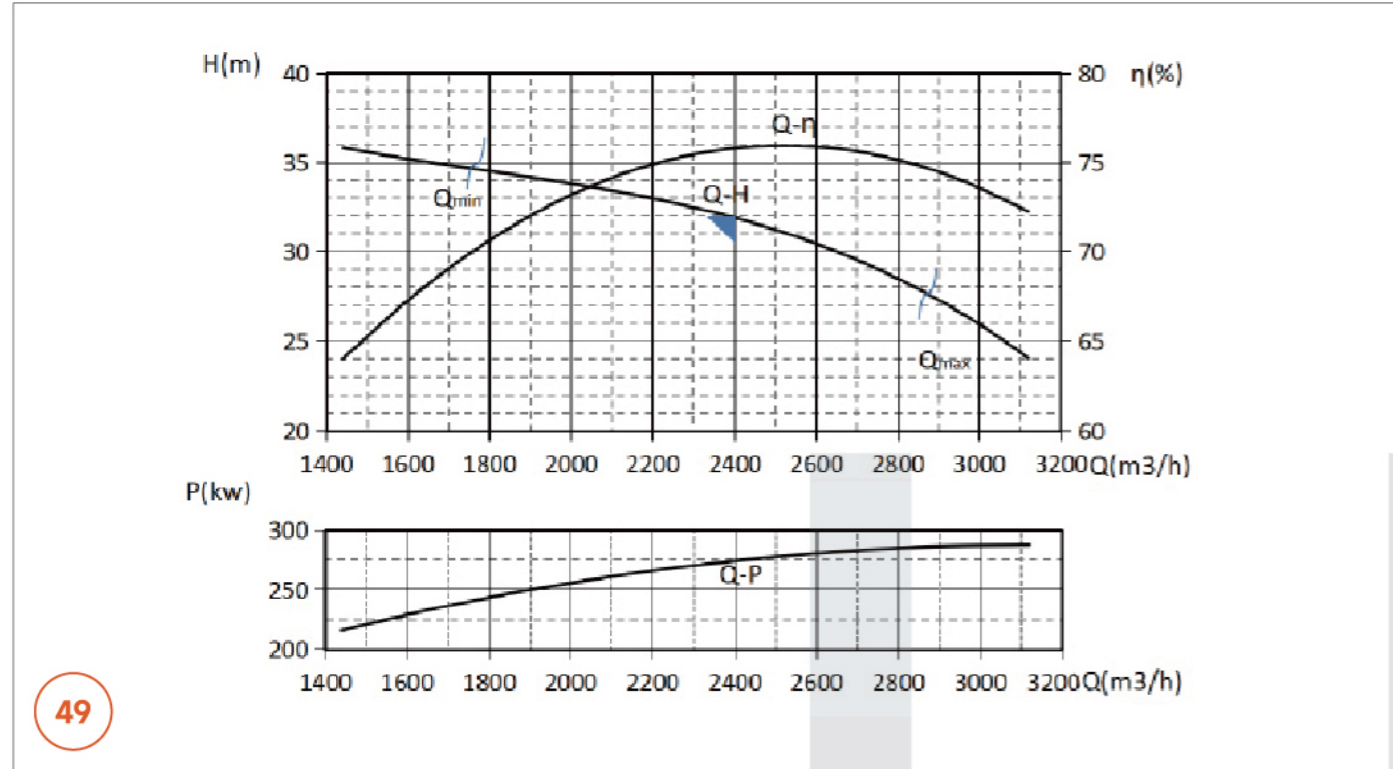

49

性能曲线图 / Performance curve

700QHD-8 型潜水混流泵性能曲线图 700QHD-8 type submersible Mixed-flow pump performance curve

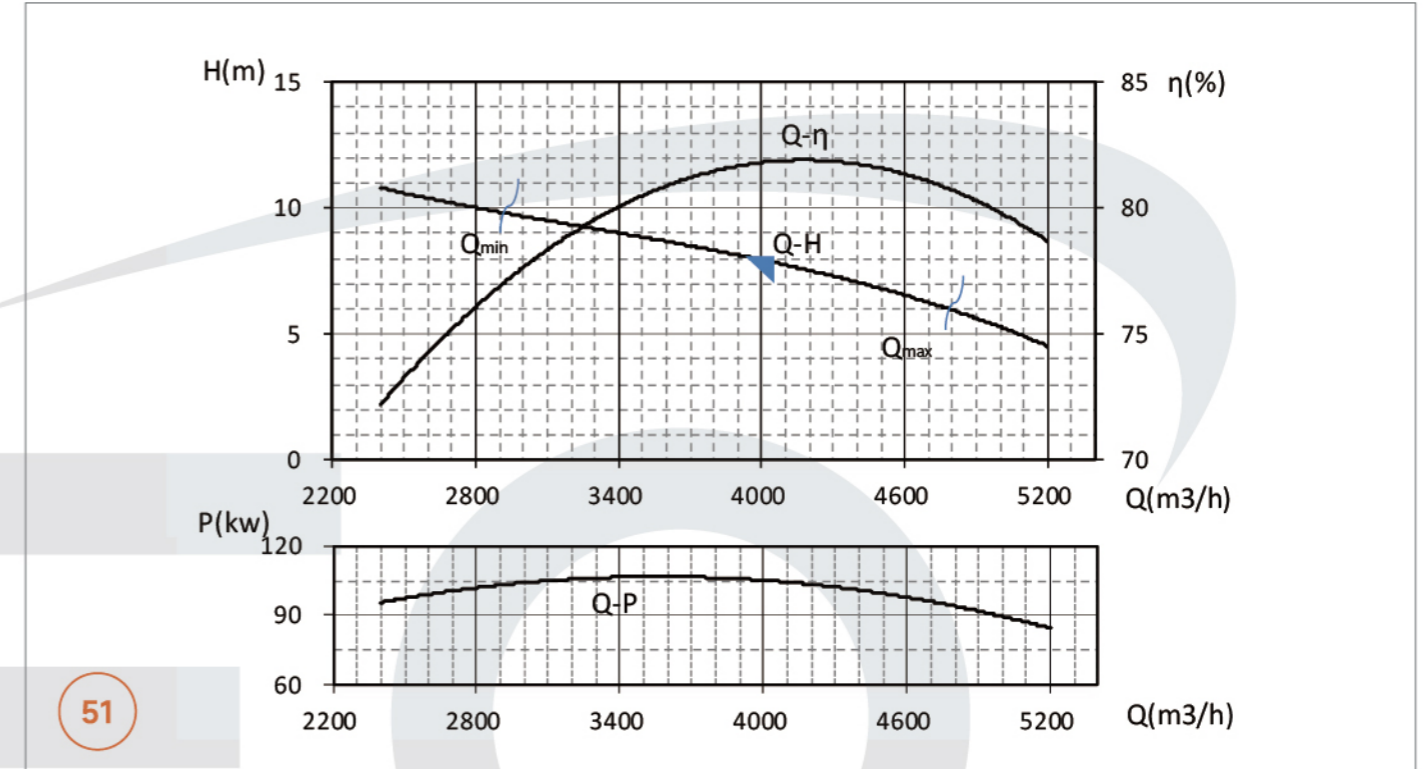

51

600QHD-35 型潜水混流泵性能曲线图 600QHD-35 submersible Mixed-flow pump performance curve

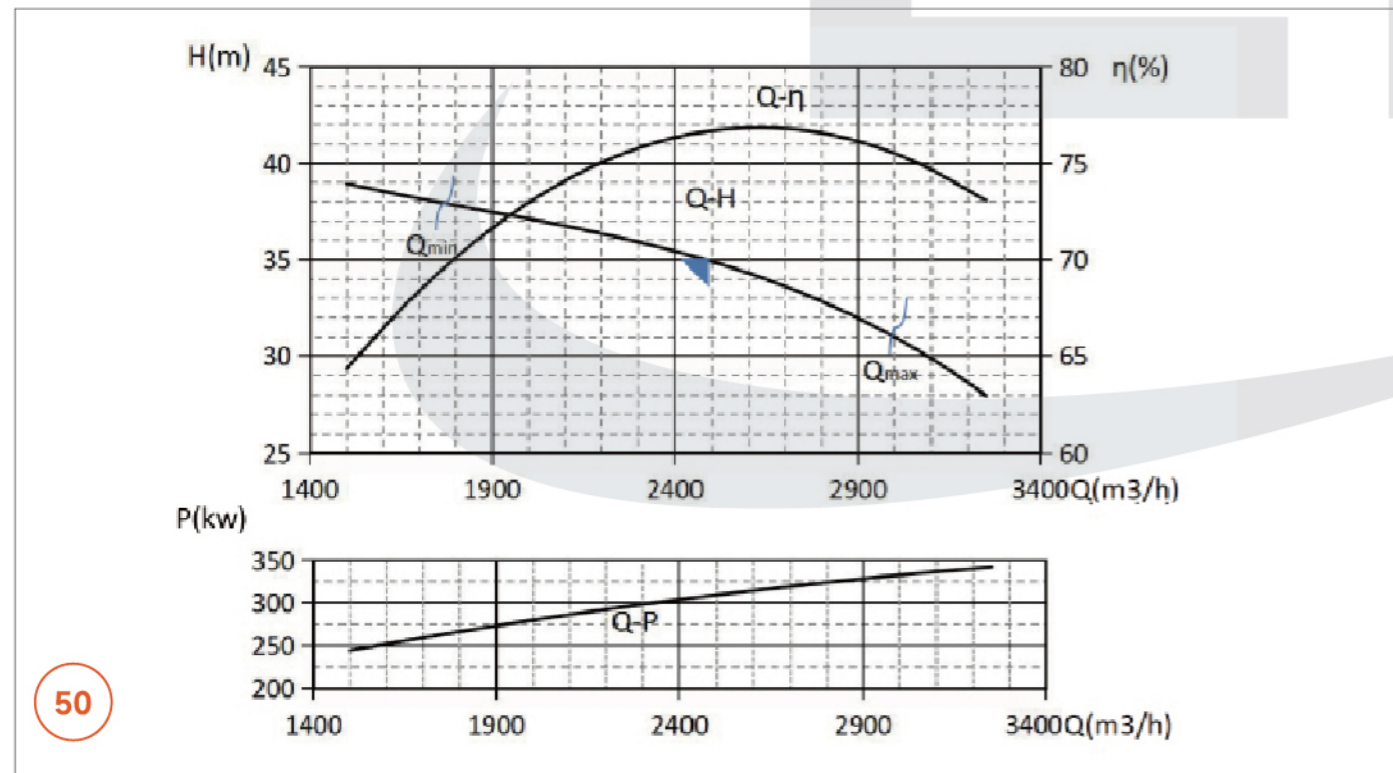

50

700QHD-9 型潜水混流泵性能曲线图 700QHD-9 type submersible Mixed-flow pump performance curve

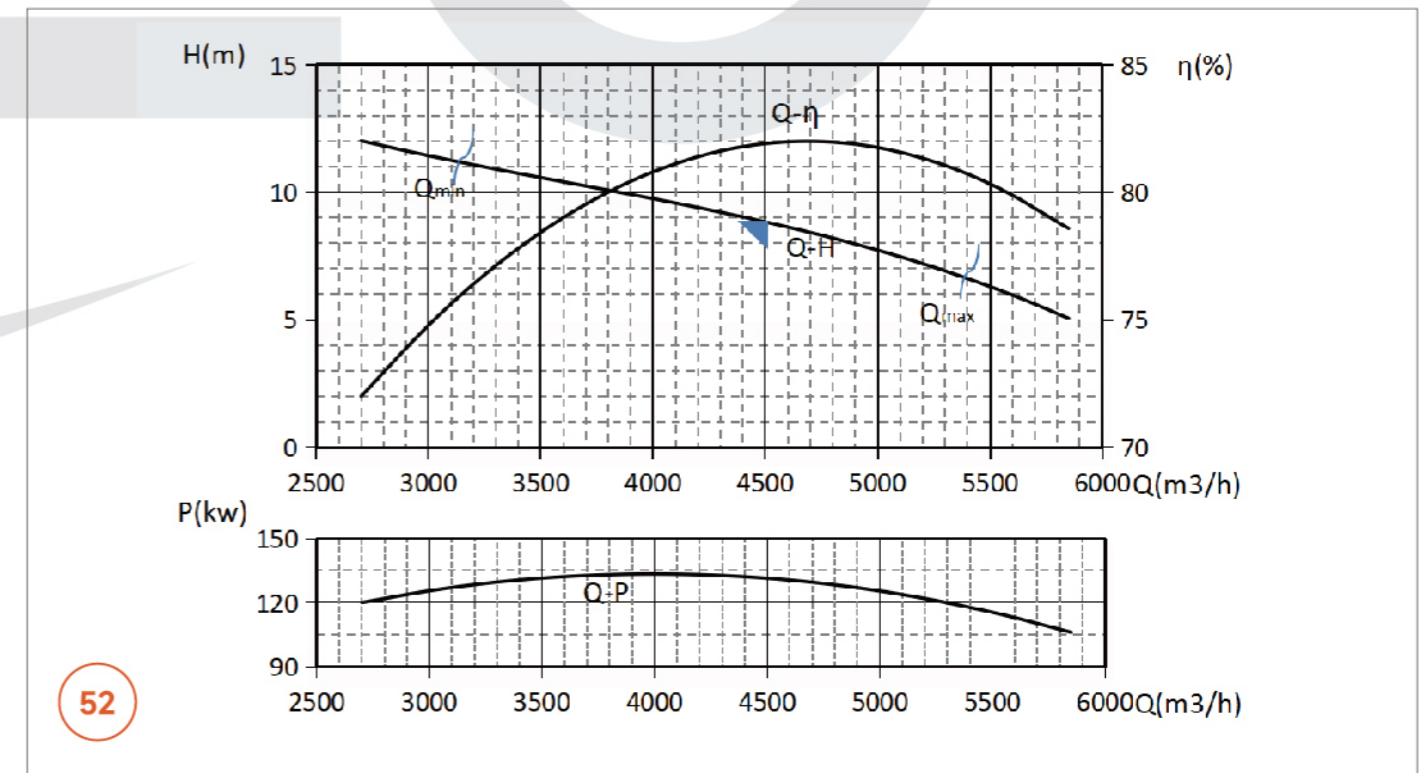

52

性能曲线图 / Performance curve

700QHD-10 型潜水混流泵性能曲线图 700QHD-10 type submersible Mixed-flow pump performance curve

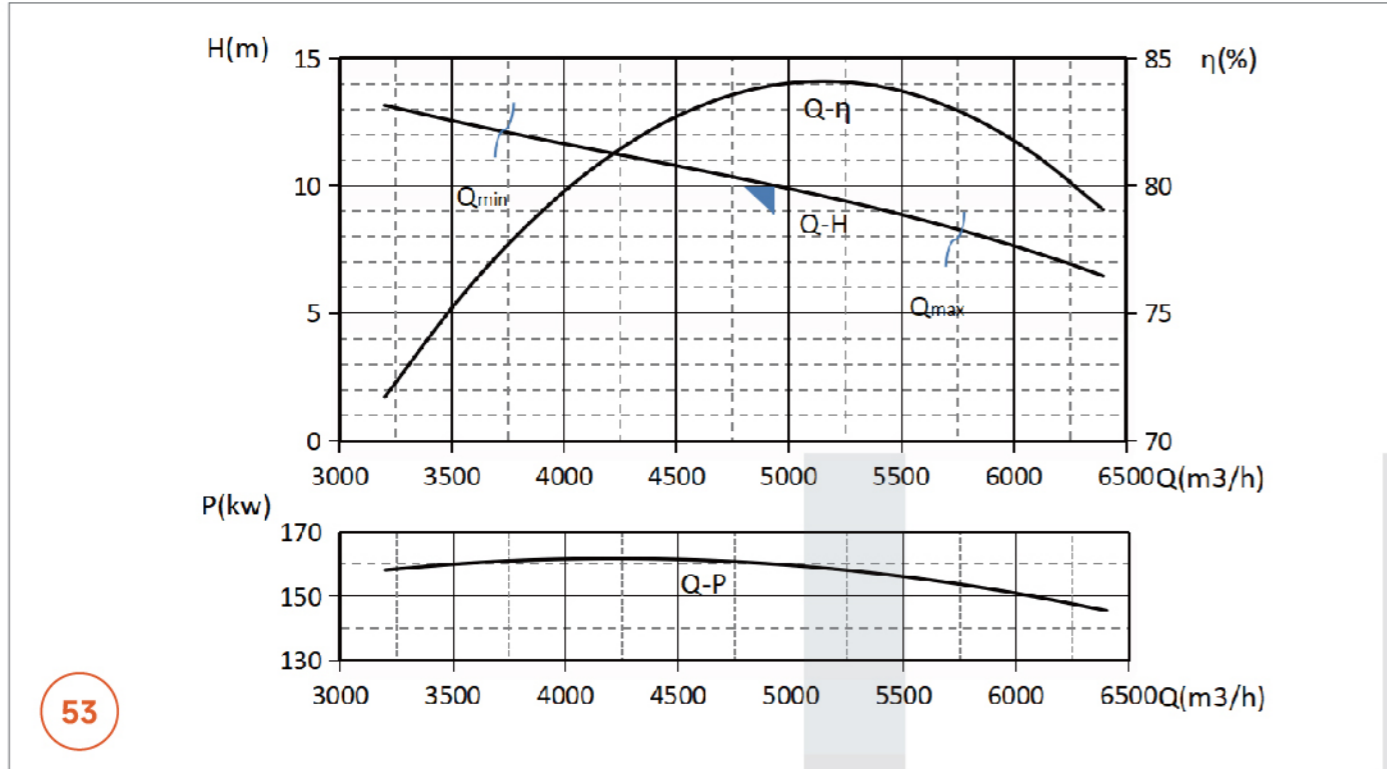

性能曲线图 / Performance curve

700QHD-18 型潜水混流泵性能曲线图 700QHD-18 type submersible Mixed-flow pump performance curve

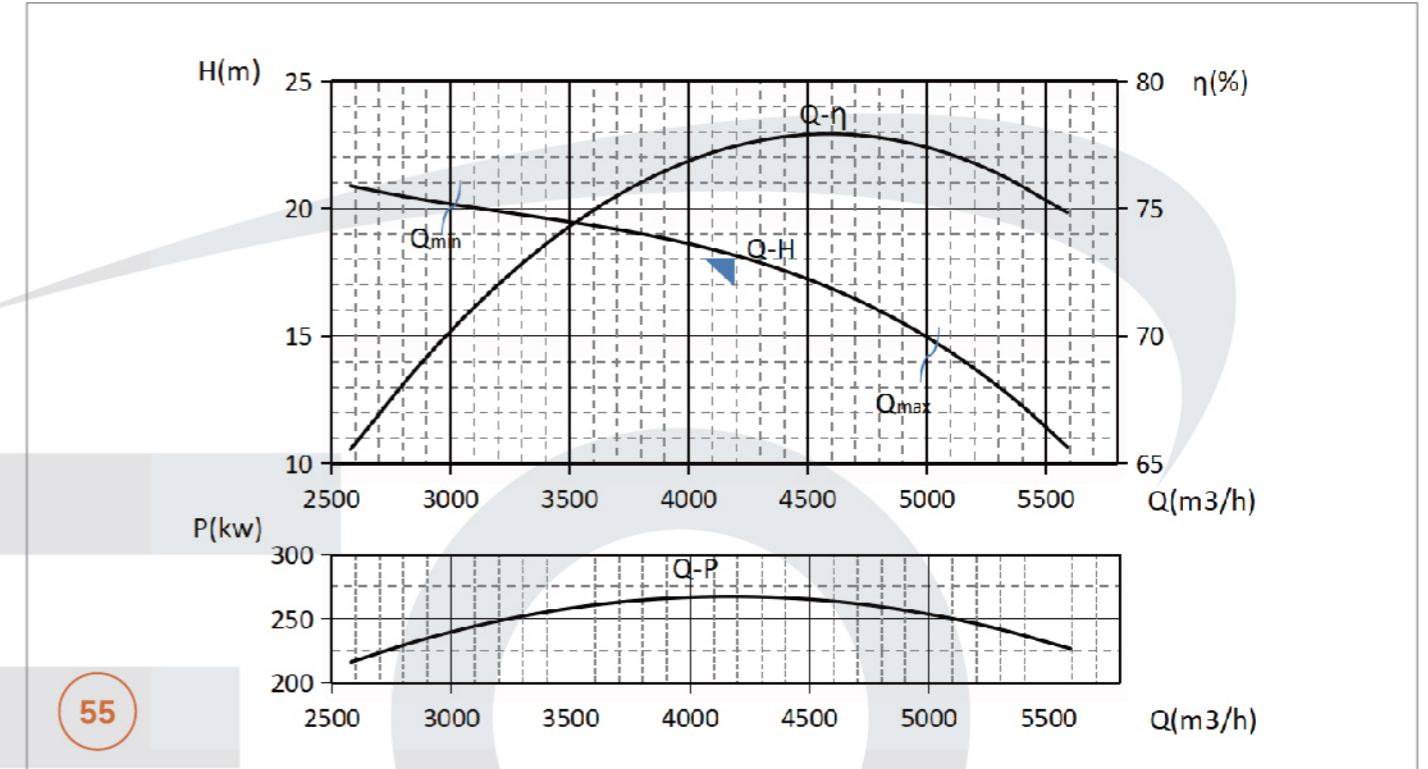

700QHD-11 型潜水混流泵性能曲线图 700QHD-11 type submersible Mixed-flow pump performance curve

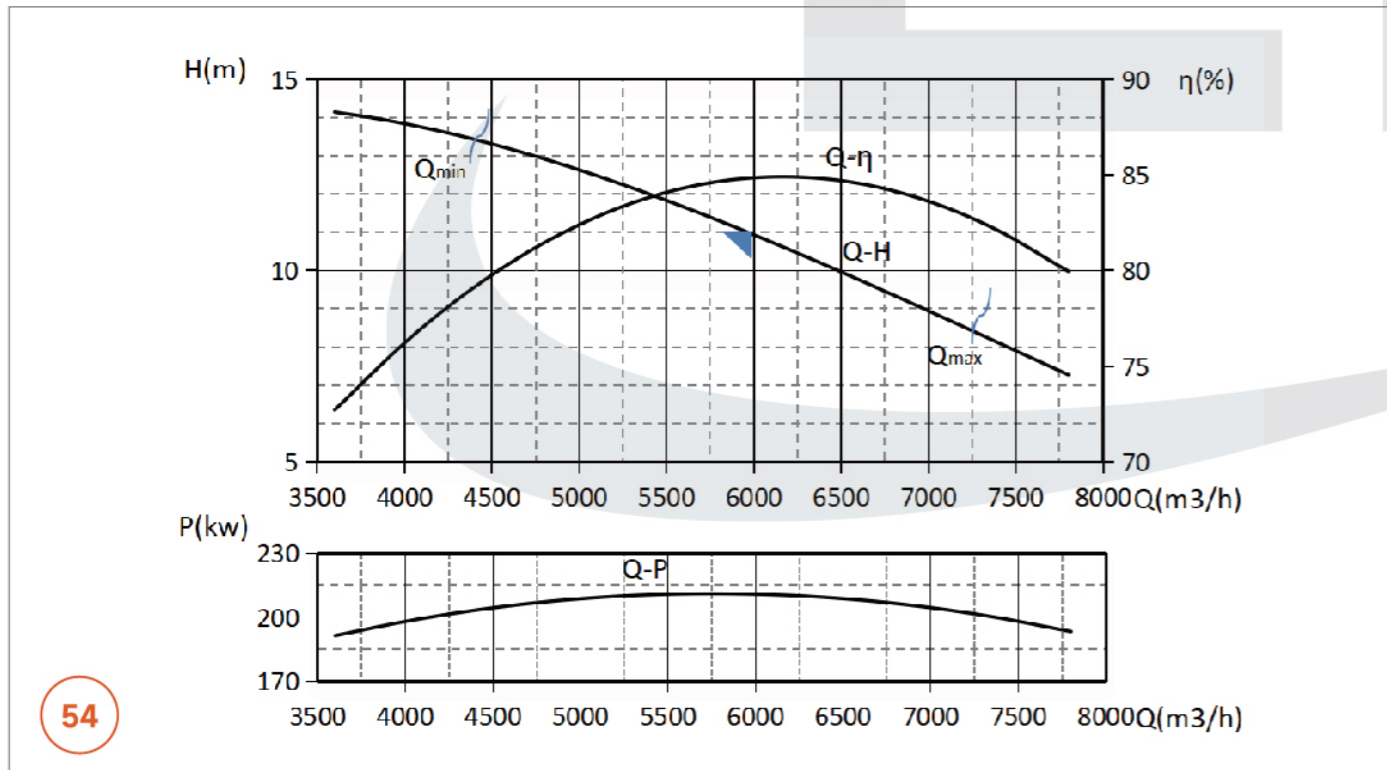

700QHD-20 型潜水混流泵性能曲线图 700QHD-20 type submersible Mixed-flow pump performance curve

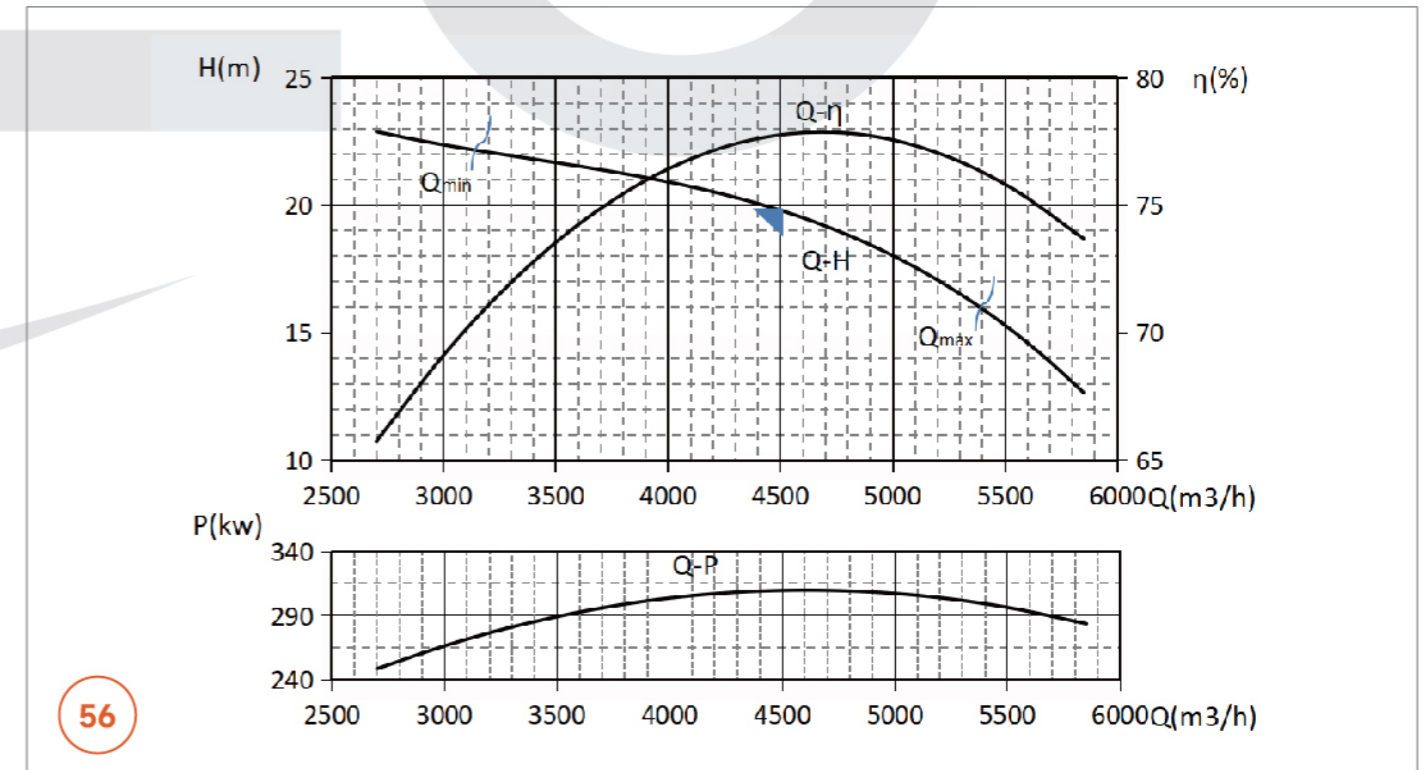

性能曲线图 / Performance curve

700QHD-22 型潜水混流泵性能曲线图 700QHD-22 type submersible Mixed-flow pump performance curve

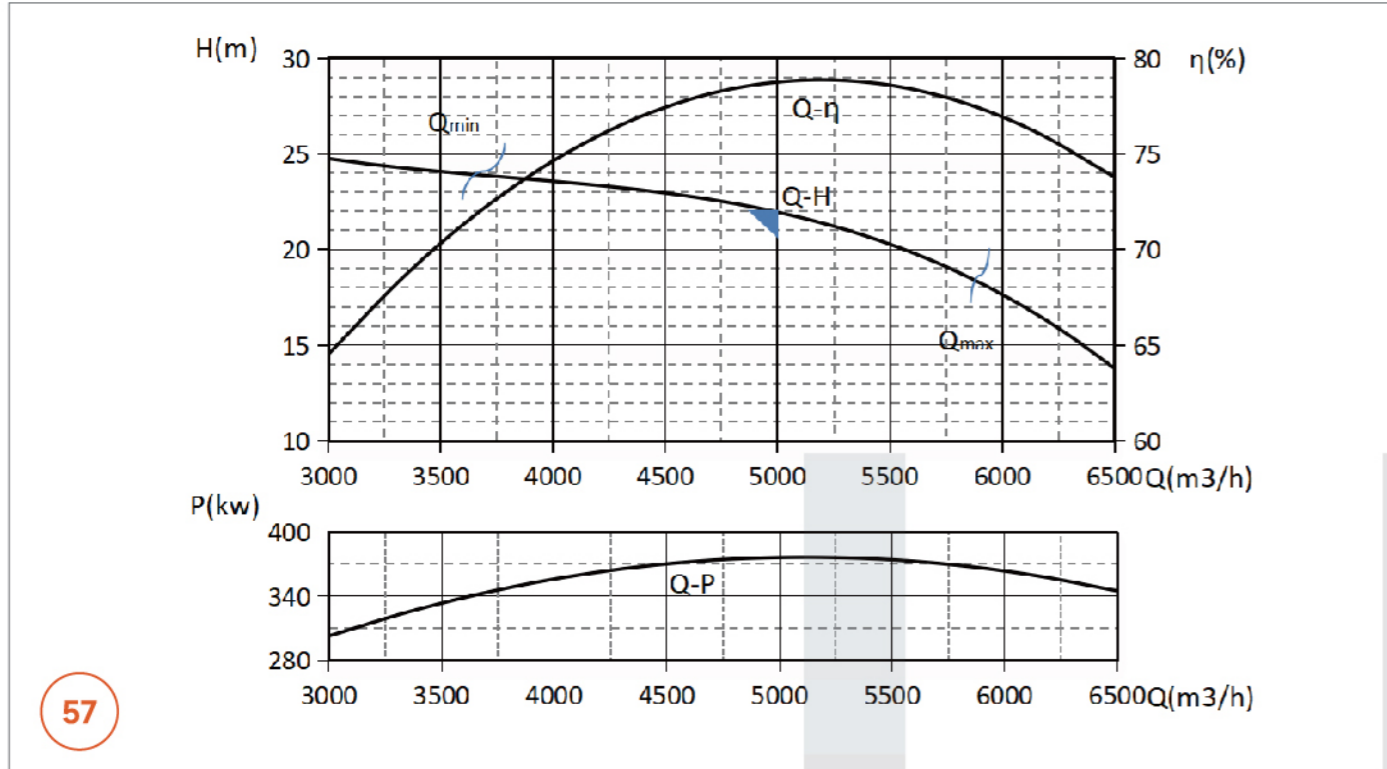

57

性能曲线图 / Performance curve

700QHD-27 型潜水混流泵性能曲线图 700QHD-27 type submersible Mixed-flow pump performance curve

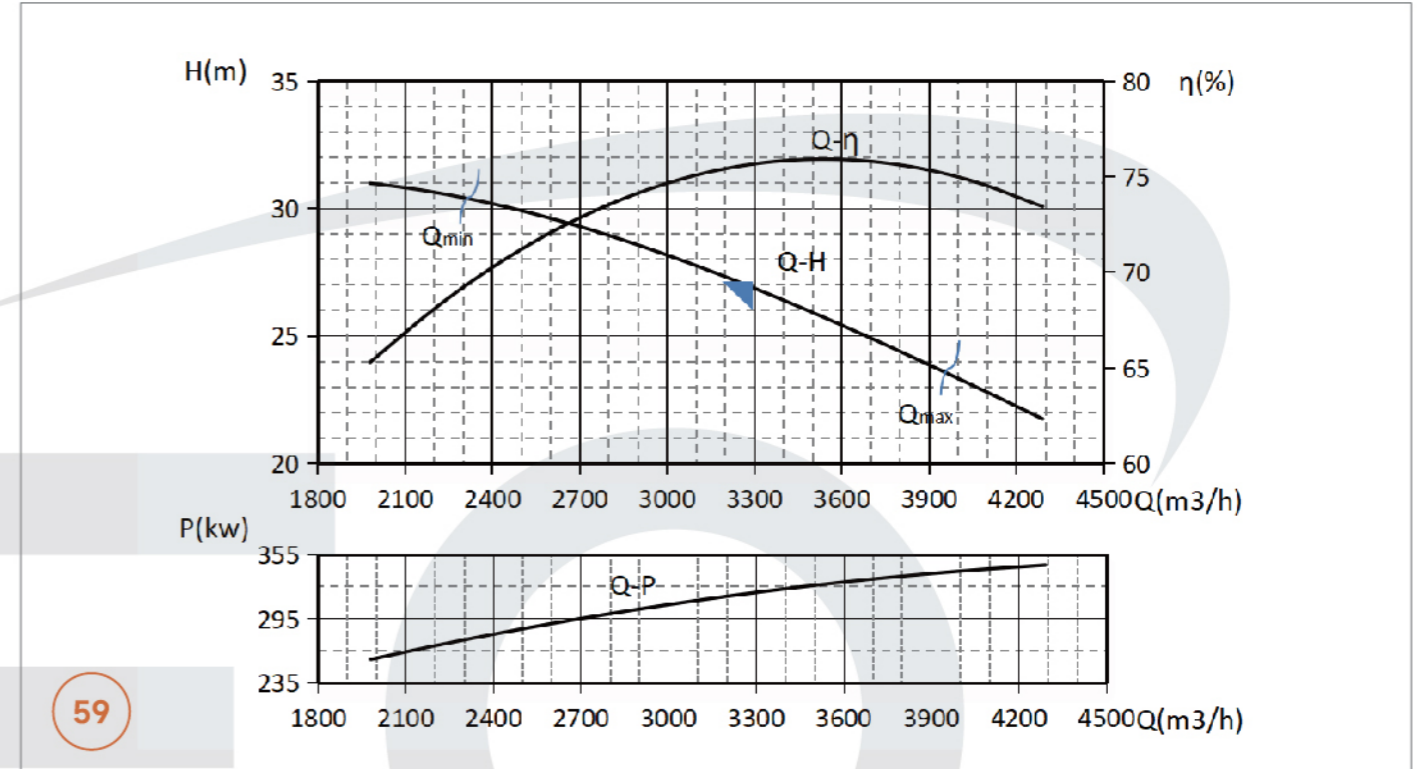

59

700QHD-24 型潜水混流泵性能曲线图 700QHD-24 type submersible Mixed-flow pump performance curve

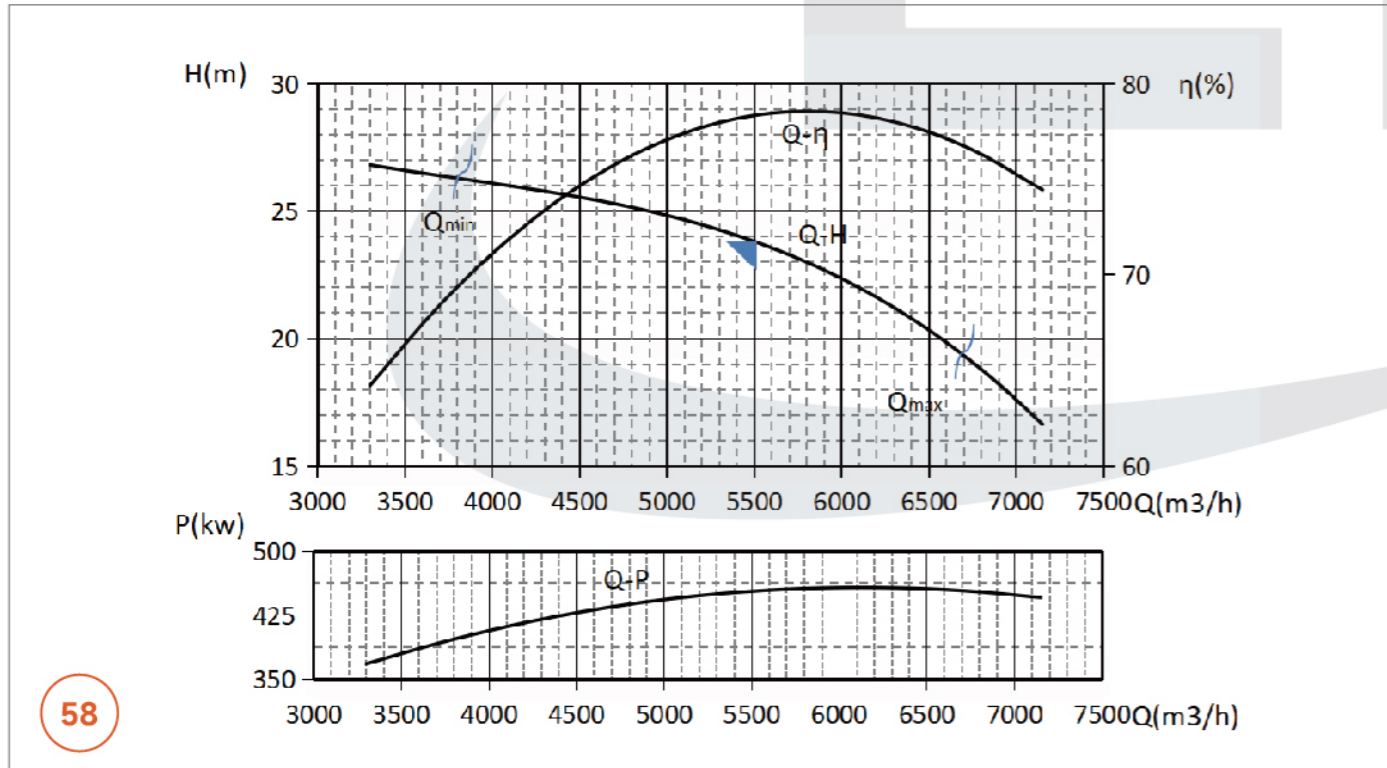

58

700QHD-30 型潜水混流泵性能曲线图 700QHD-30 type submersible Mixed-flow pump performance curve

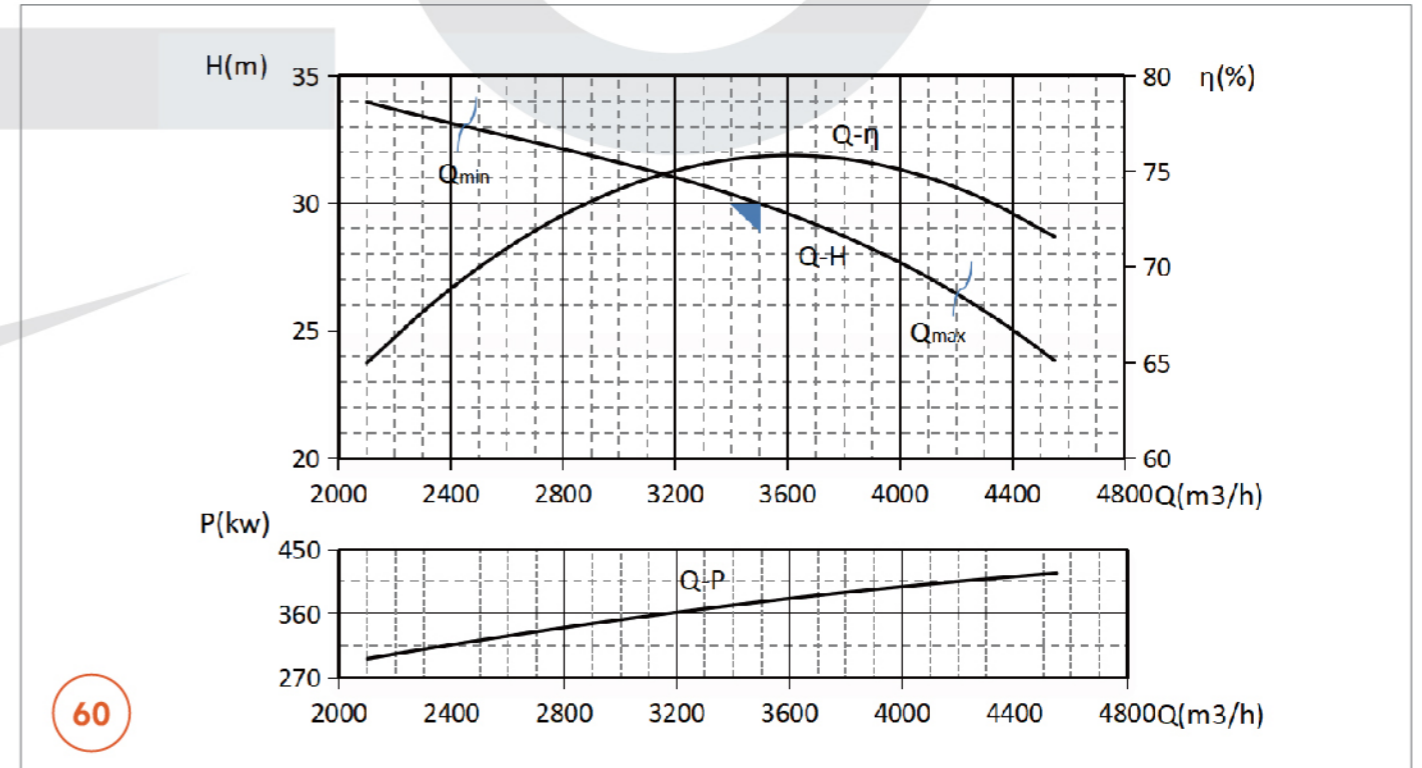

60

性能曲线图 / Performance curve

700QHD-32 型潜水混流泵性能曲线图 700QHD-32 type submersible Mixed-flow pump performance curve

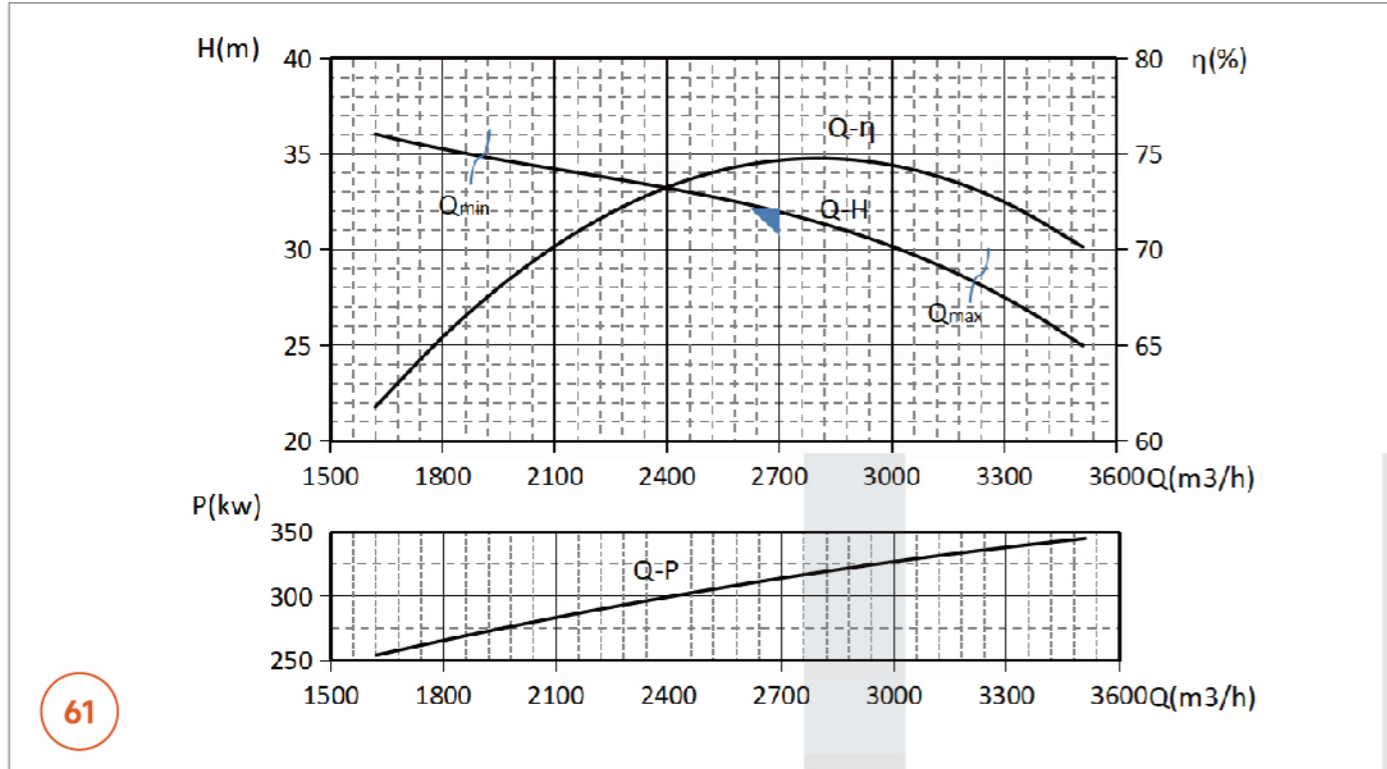

61

性能曲线图 / Performance curve

700QHD-37 型潜水混流泵性能曲线图 700QHD-37 type submersible Mixed-flow pump performance curve

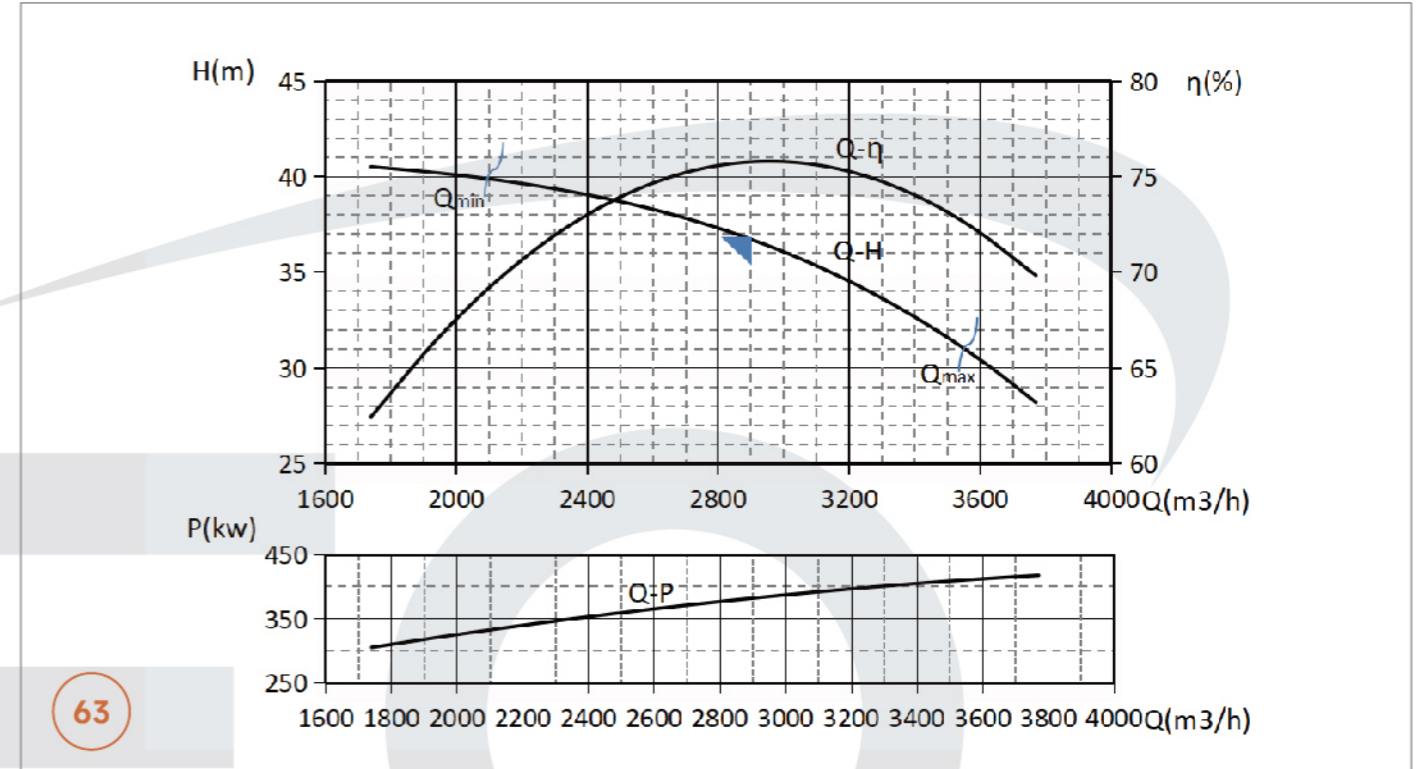

63

700QHD-35 型潜水混流泵性能曲线图 700QHD-35 type submersible Mixed-flow pump performance curve

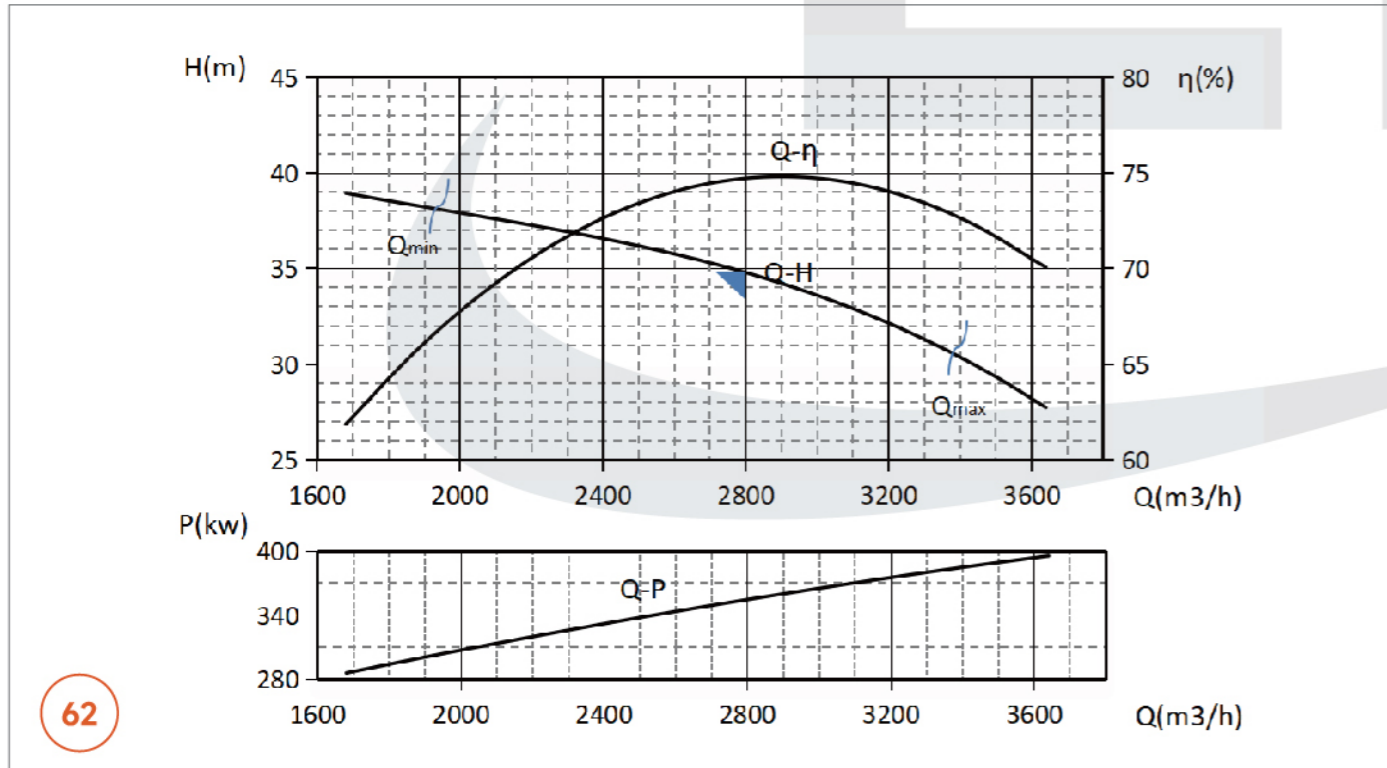

62

700QHD-40 型潜水混流泵性能曲线图 700QHD-40 type submersible Mixed-flow pump performance curve

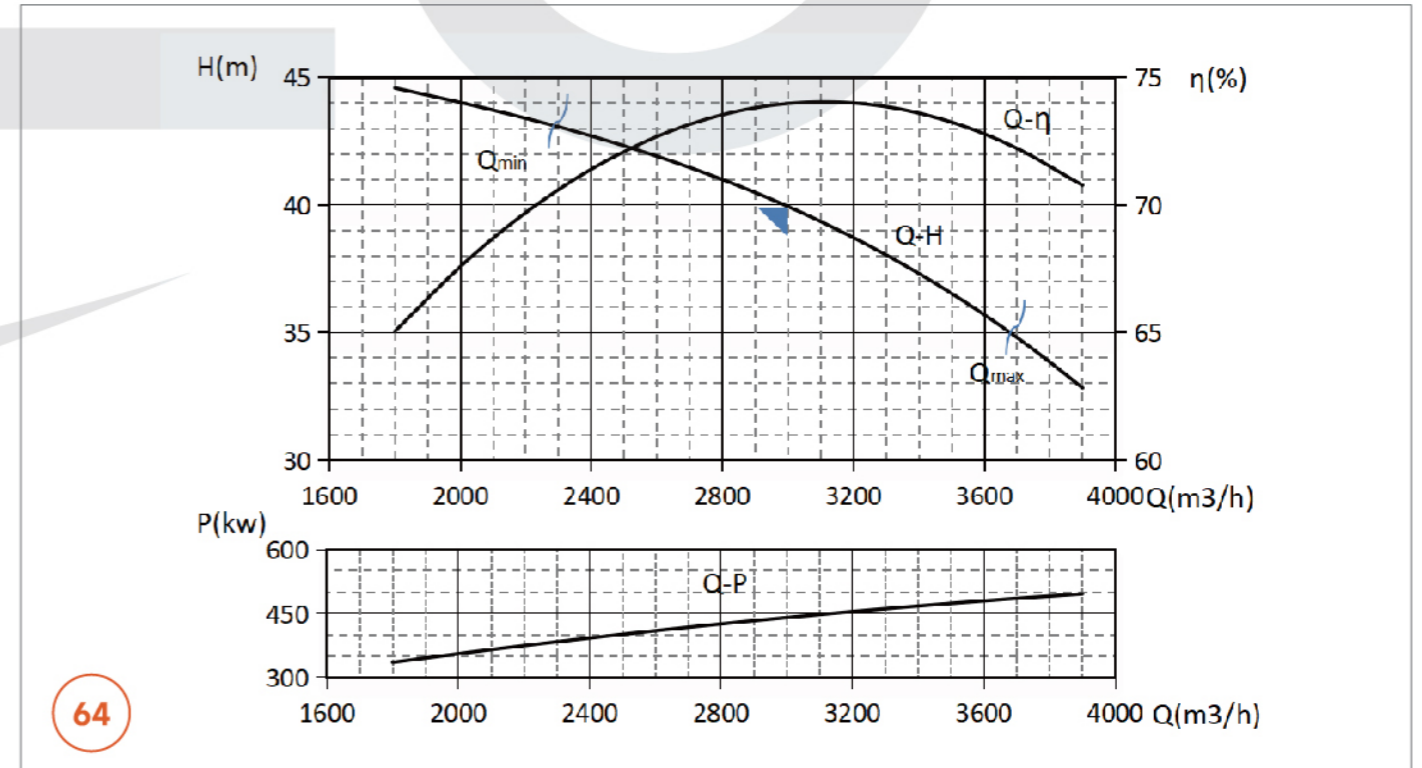

64

性能曲线图 / Performance curve

700QHD-42 型潜水混流泵性能曲线图 700QHD-42 type submersible Mixed-flow pump performance curve

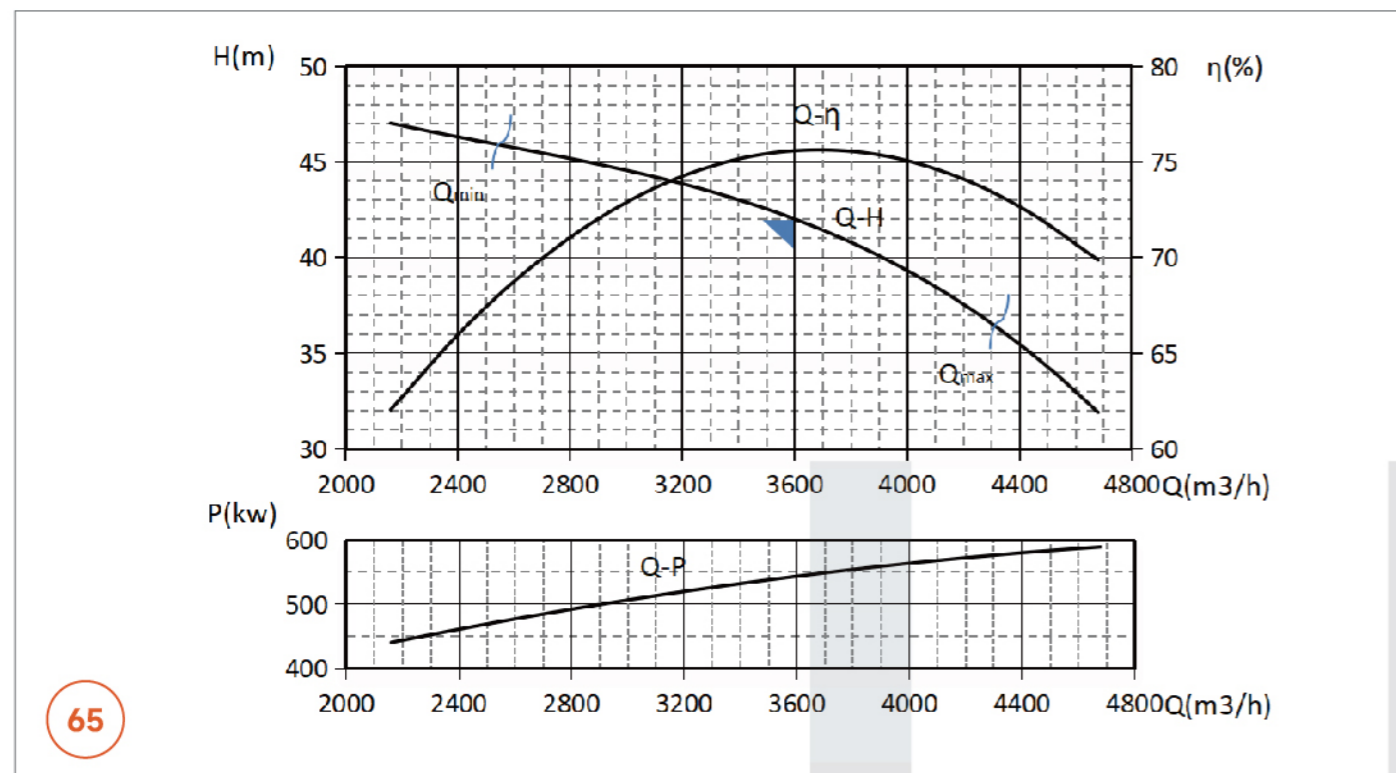

65

性能曲线图 / Performance curve

700QHD-50 型潜水混流泵性能曲线图 700QHD-50 type submersible Mixed-flow pump performance curve

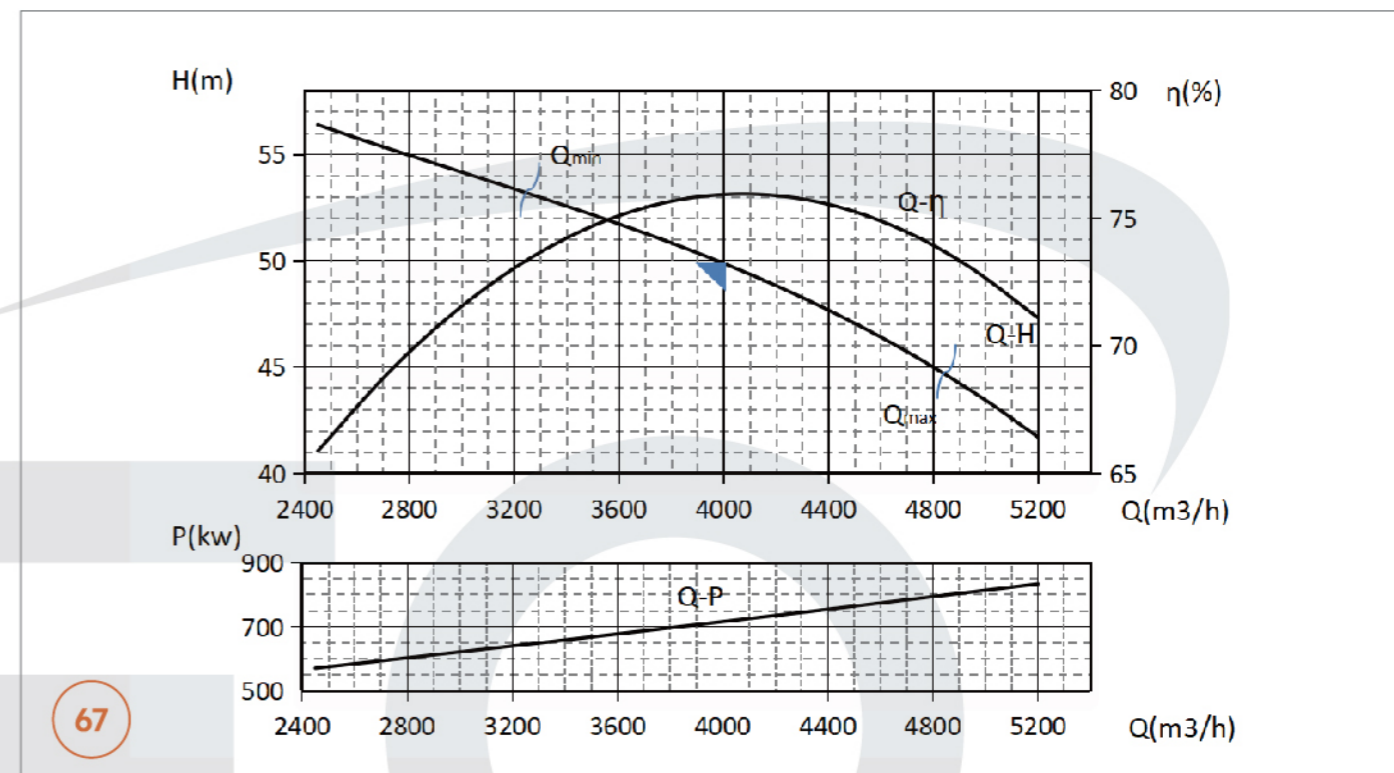

67

700QHD-45 型潜水混流泵性能曲线图 700QHD-45 type submersible Mixed-flow pump performance curve

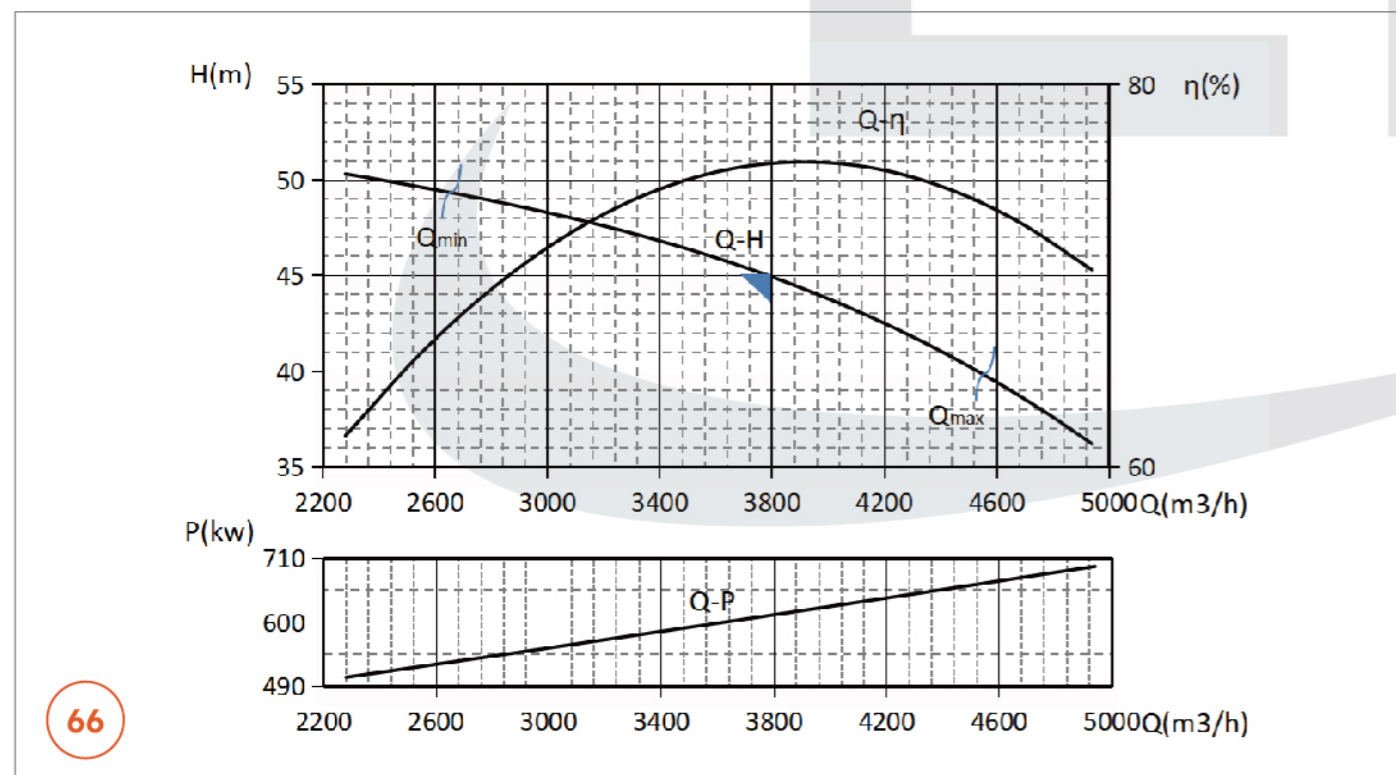

66

800QHD-12 型潜水混流泵性能曲线图 800QHD-12 type submersible Mixed-flow pump performance curve

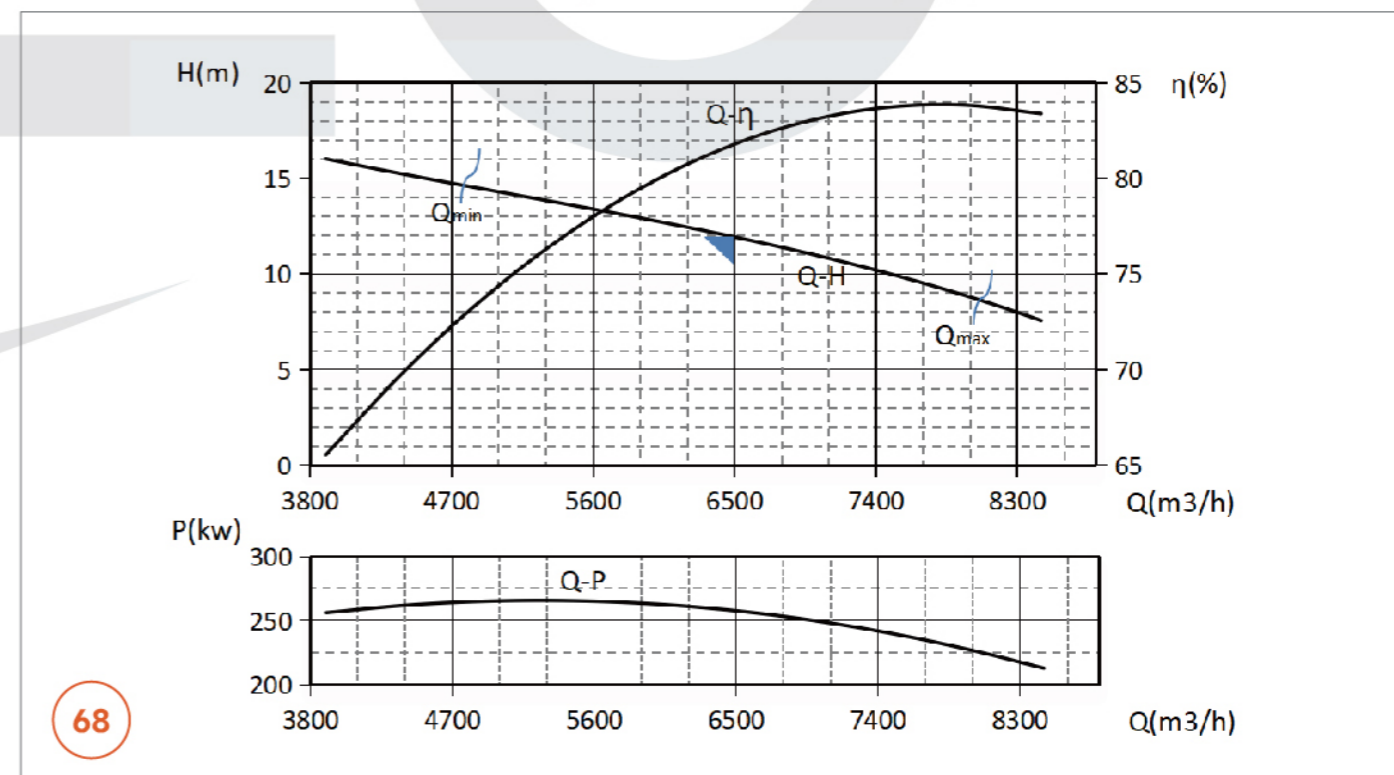

68

性能曲线图 / Performance curve

800QHD-14 型潜水混流泵性能曲线图 800QHD-14 type submersible Mixed-flow pump performance curve

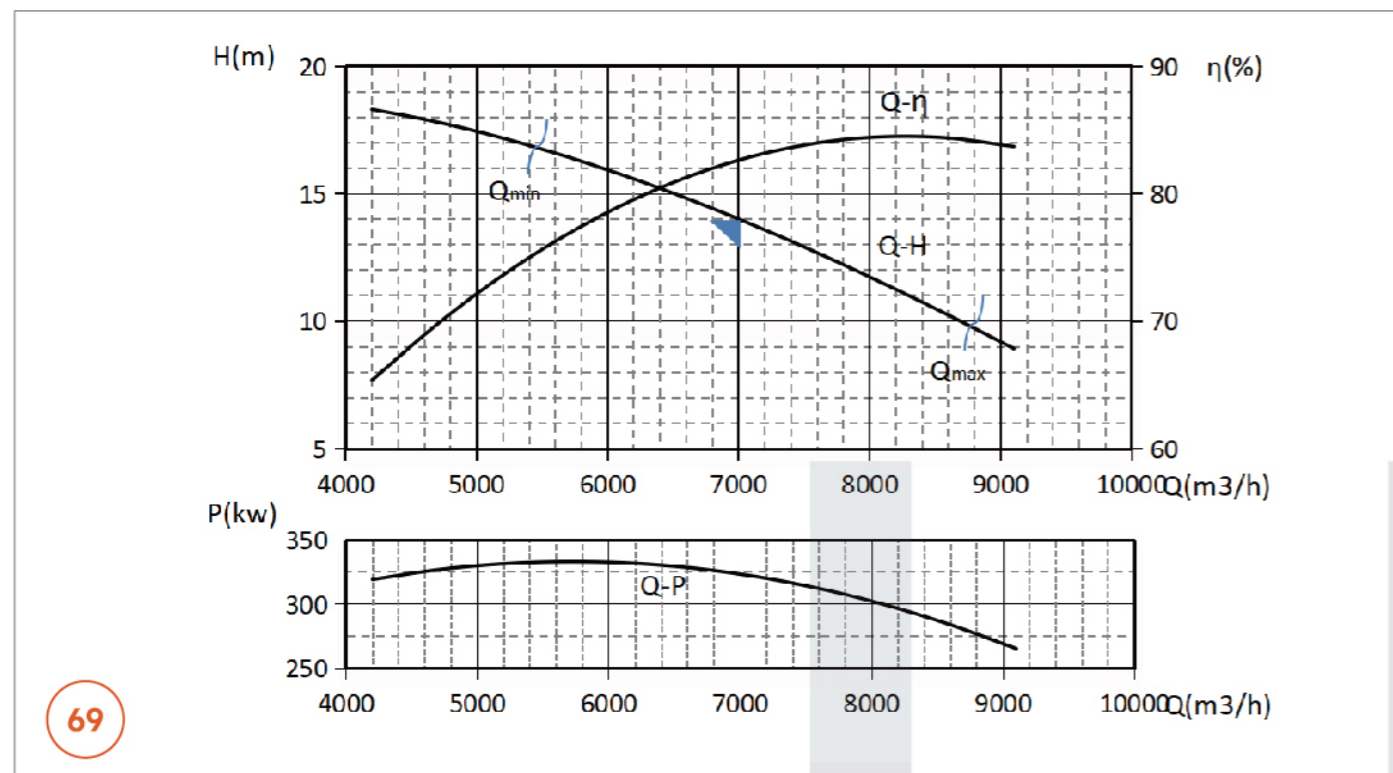

69

性能曲线图 / Performance curve

800QHD-18 型潜水混流泵性能曲线图 800QHD-18 type submersible Mixed-flow pump performance curve

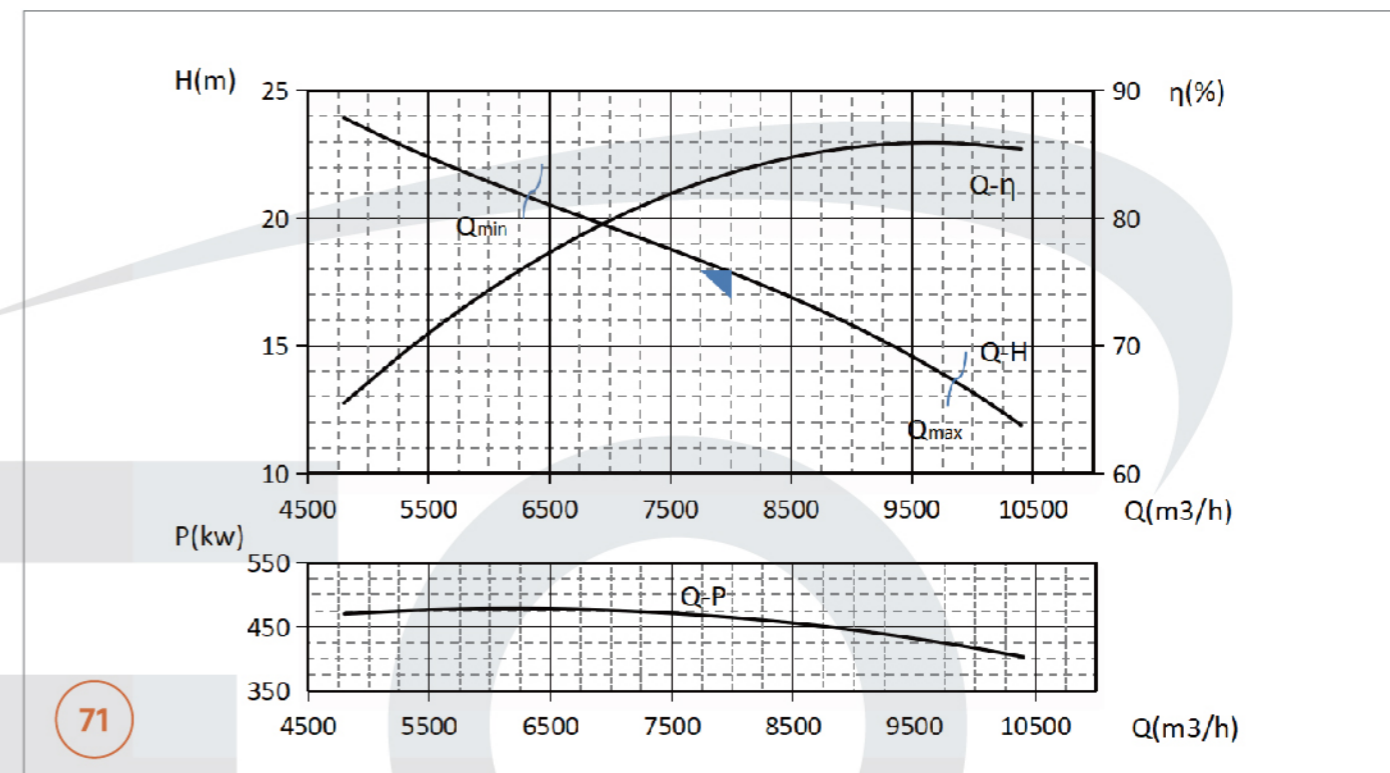

71

800QHD-16 型潜水混流泵性能曲线图 800QHD-16 type submersible Mixed-flow pump performance curve

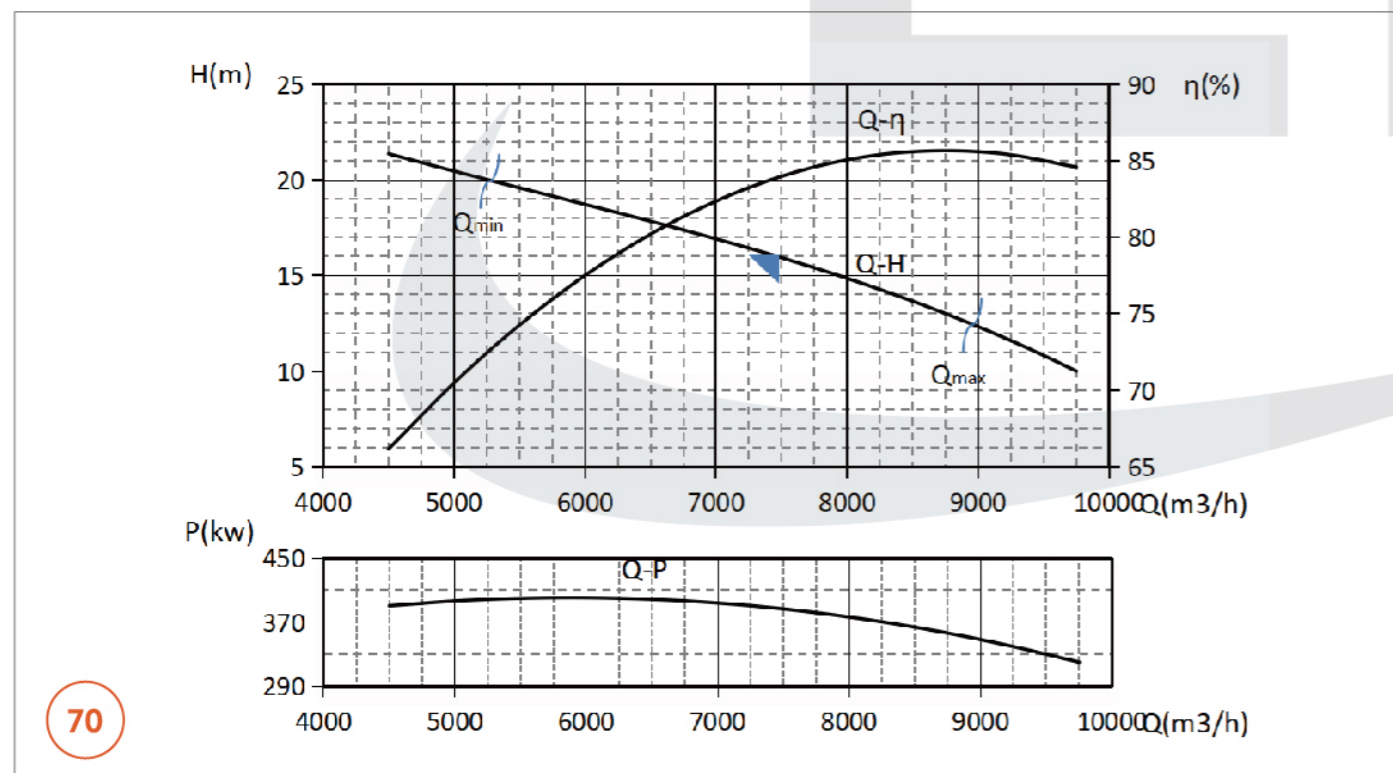

70

800QHD-25 型潜水混流泵性能曲线图 800QHD-25 type submersible Mixed-flow pump performance curve

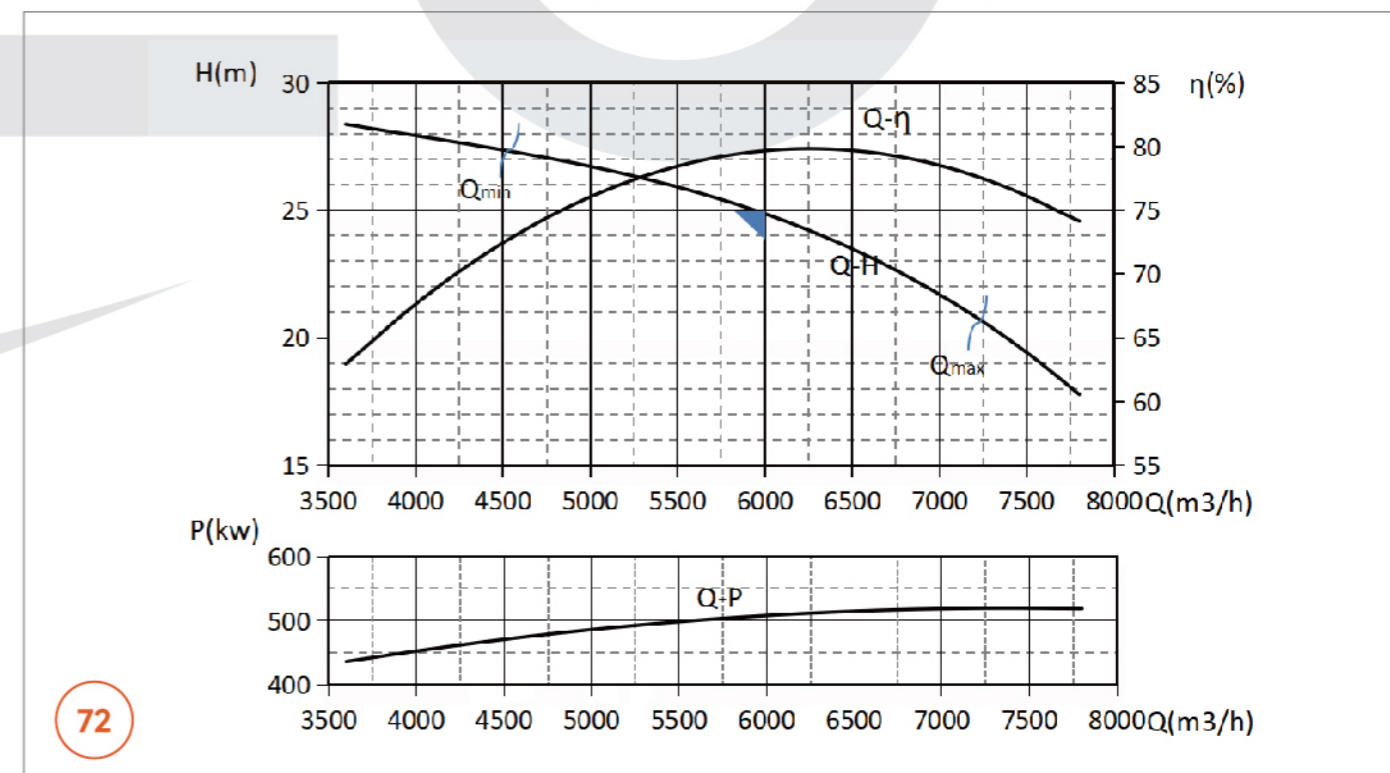

72

性能曲线图 / Performance curve

800QHD-28 型潜水混流泵性能曲线图 800QHD-28 type submersible Mixed-flow pump performance curve

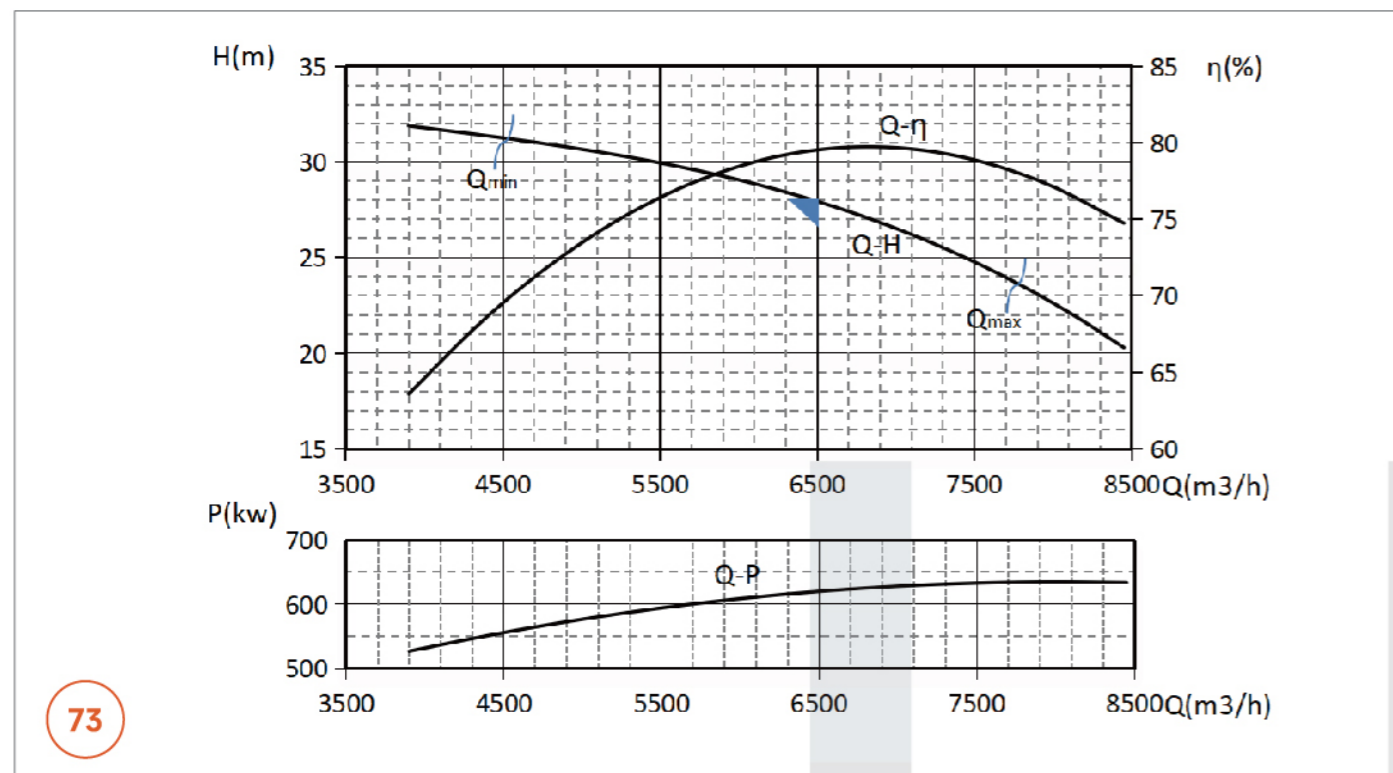

73

性能曲线图 / Performance curve

800QHD-33 型潜水混流泵性能曲线图 800QHD-33 type submersible Mixed-flow pump performance curve

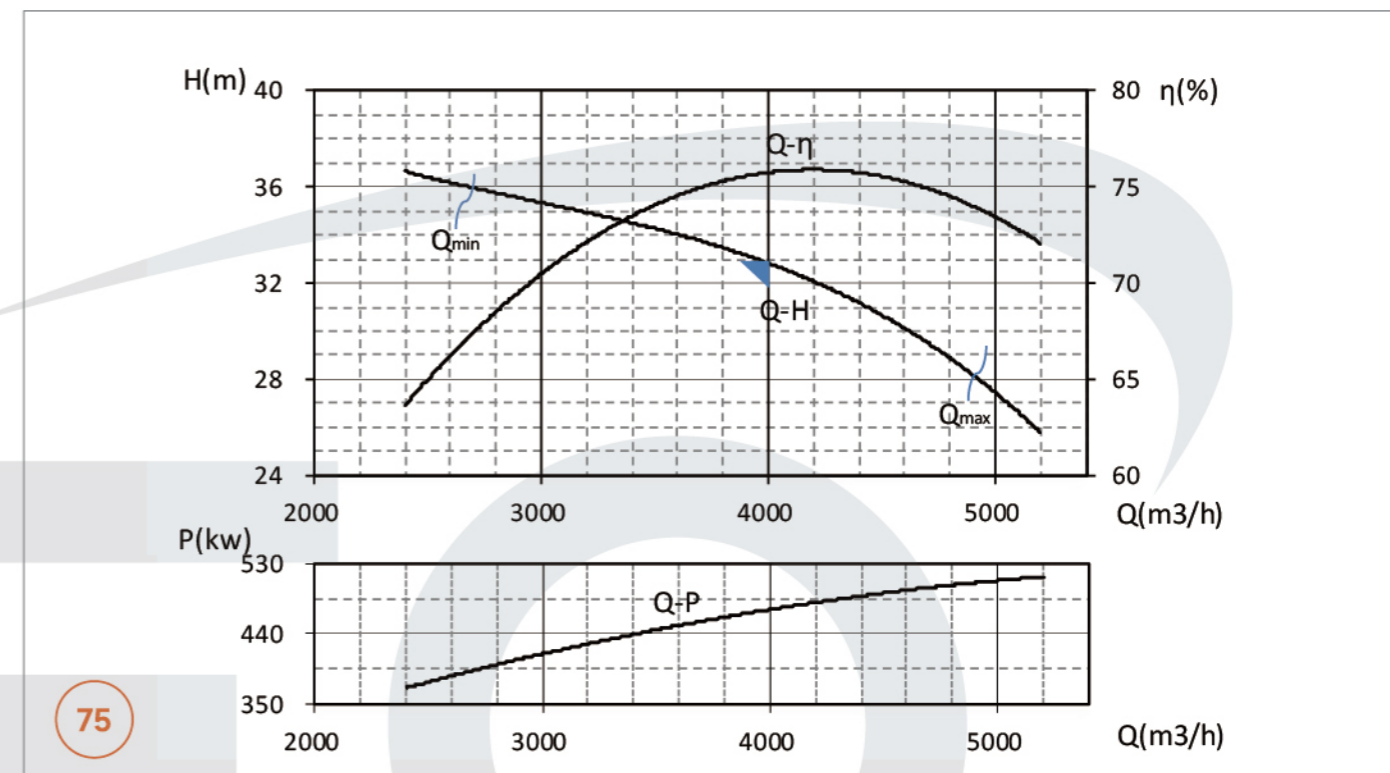

75

800QHD-31 型潜水混流泵性能曲线图 800QHD-31 type submersible Mixed-flow pump performance curve

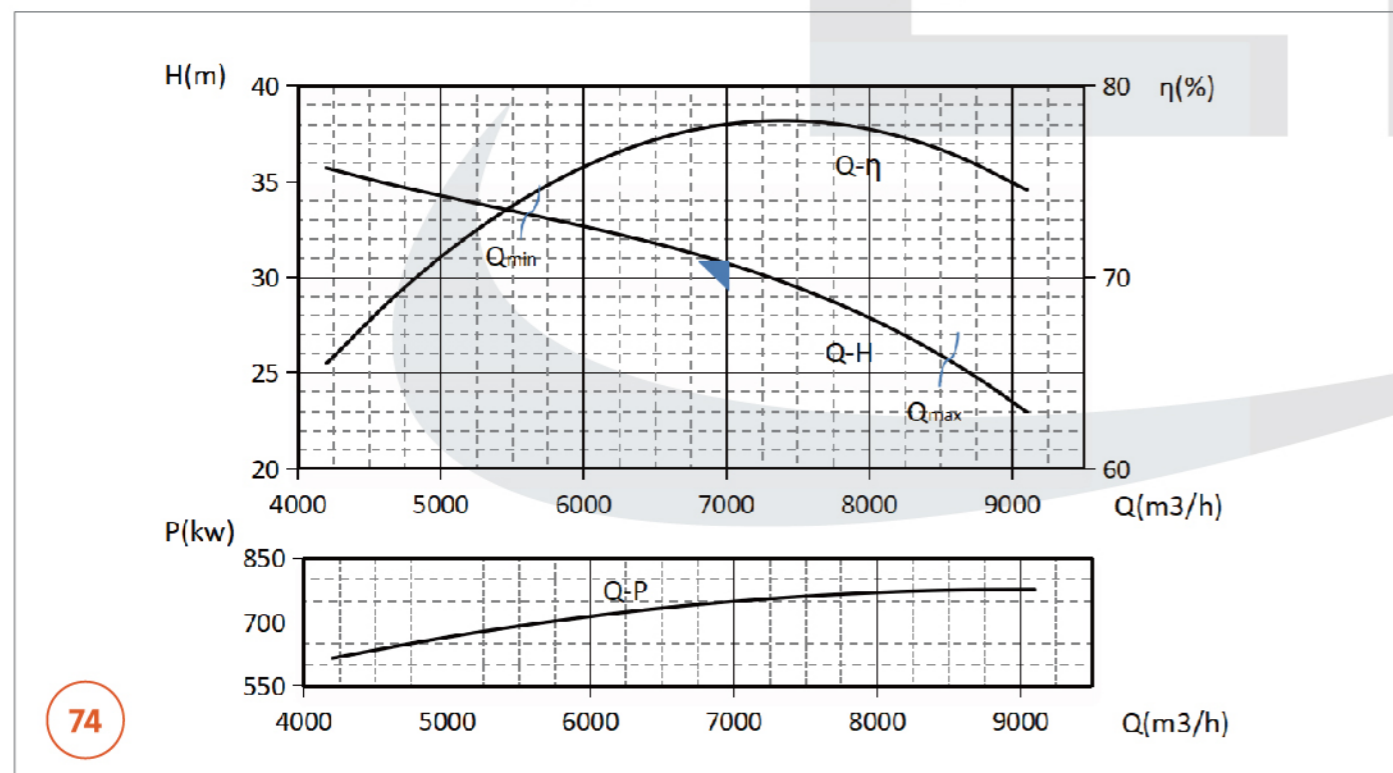

74

800QHD-35 型潜水混流泵性能曲线图 800QHD-35 type submersible Mixed-flow pump performance curve

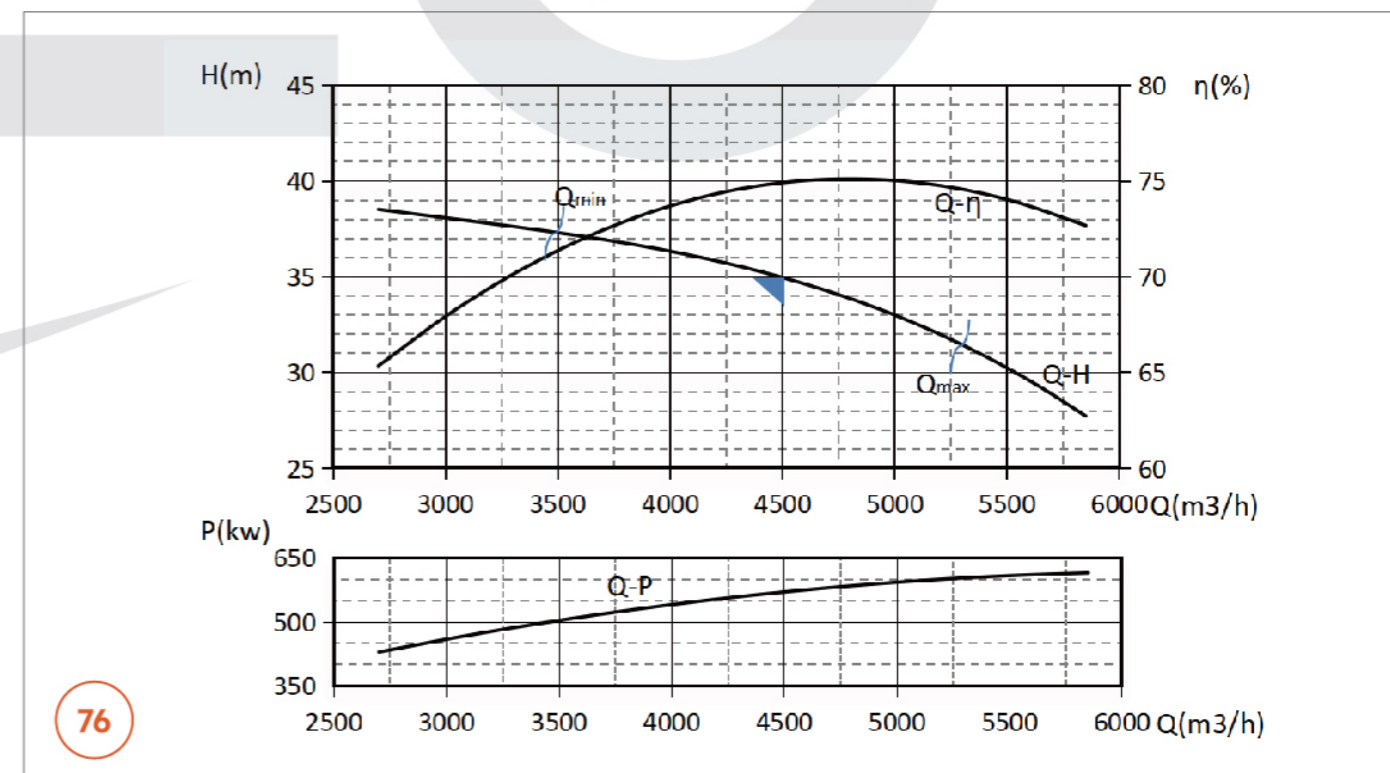

76

性能曲线图 / Performance curve

800QHD-38 型潜水混流泵性能曲线图 800QHD-38 type submersible Mixed-flow pump performance curve

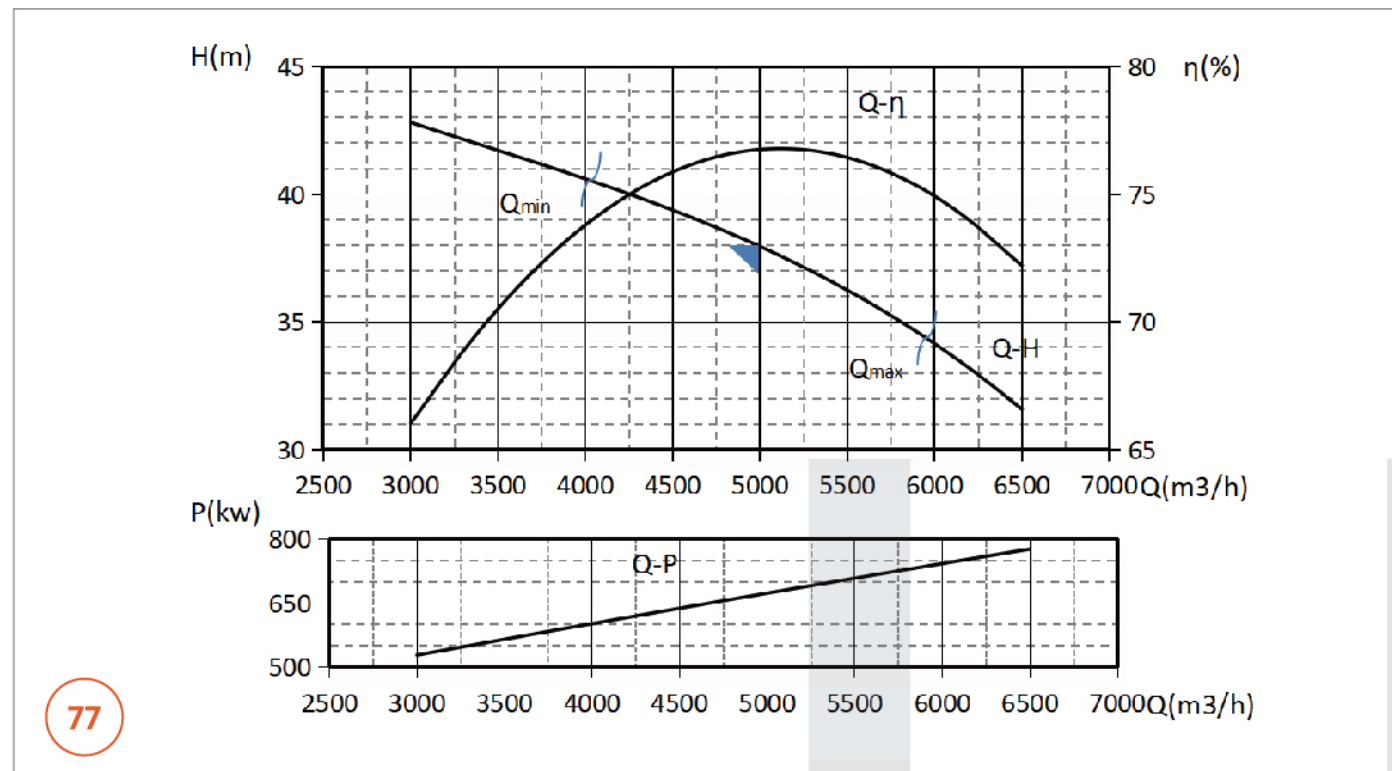

性能曲线图 / Performance curve

900QHD-10 型潜水混流泵性能曲线图 900QHD-10 type submersible Mixed-flow pump performance curve

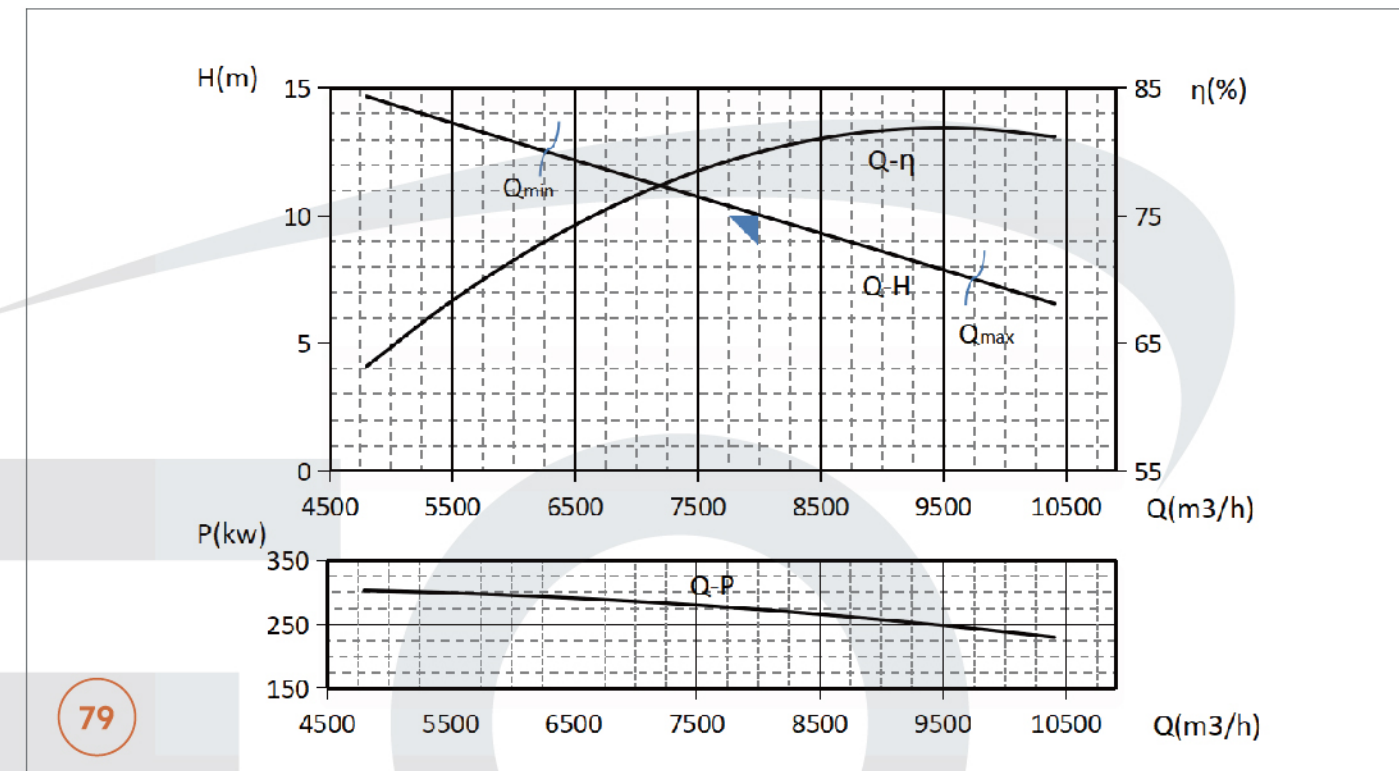

900QHD-9 型潜水混流泵性能曲线图 900QHD-9 type submersible Mixed-flow pump performance curve

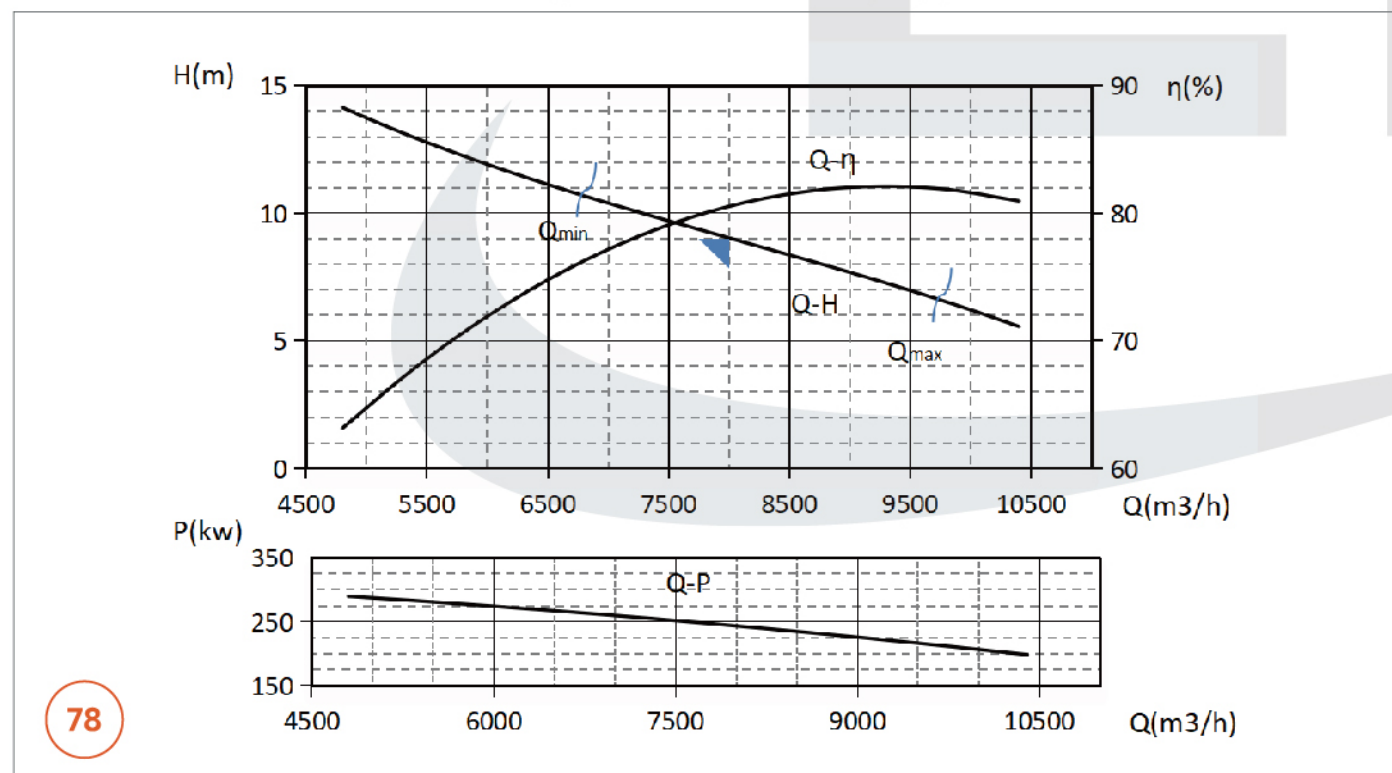

900QHD-11 型潜水混流泵性能曲线图 900QHD-11 type submersible Mixed-flow pump performance curve

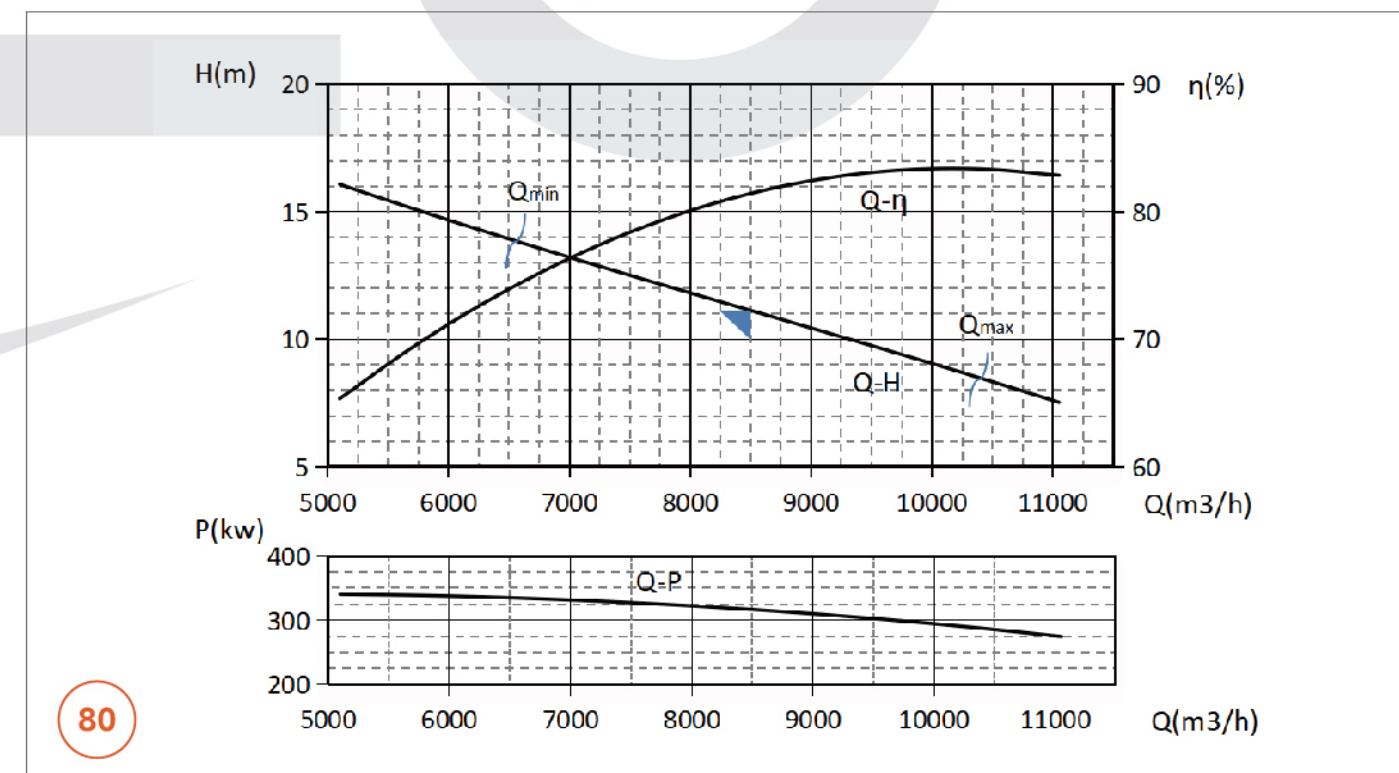

性能曲线图 / Performance curve

900QHD-12 型潜水混流泵性能曲线图 900QHD-12 type submersible Mixed-flow pump performance curve

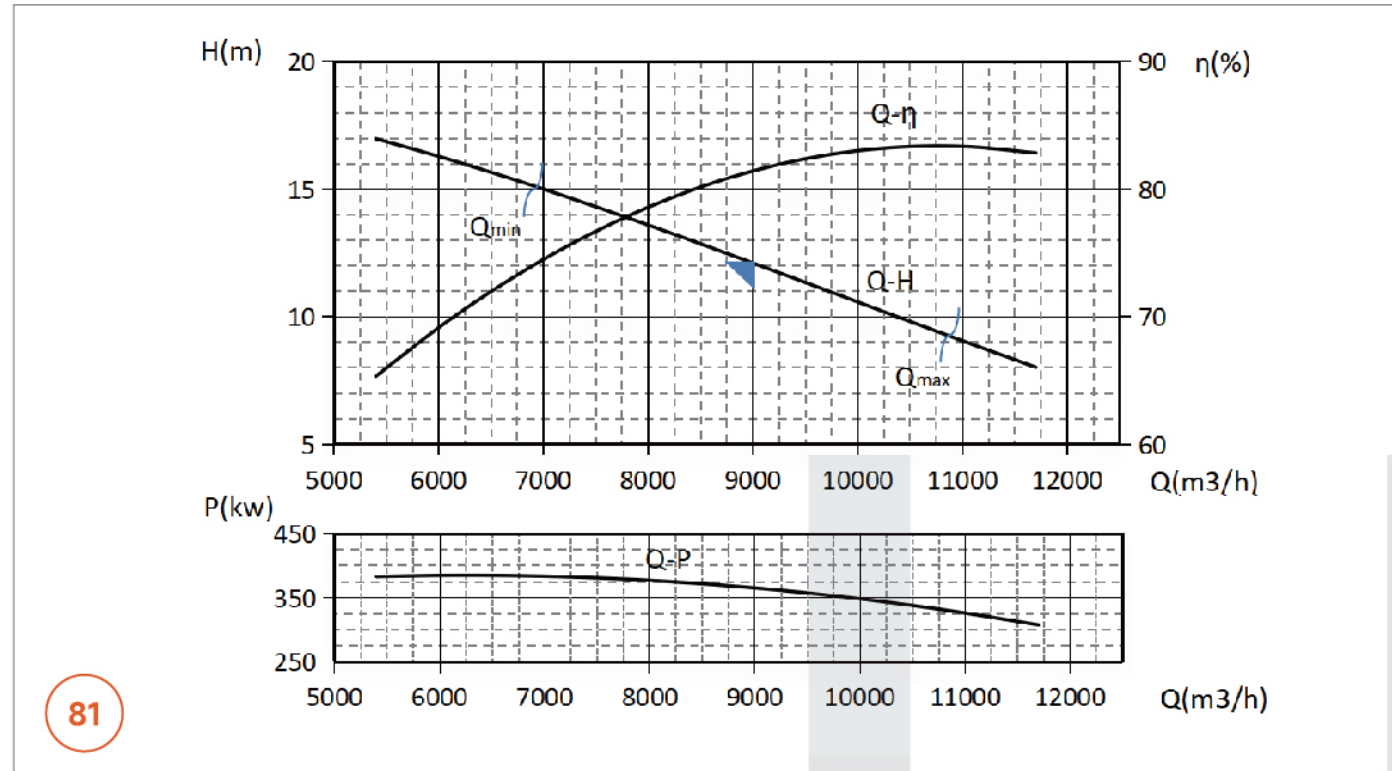

81

性能曲线图 / Performance curve

900QHD-14 型潜水混流泵性能曲线图 900QHD-14 type submersible Mixed-flow pump performance curve

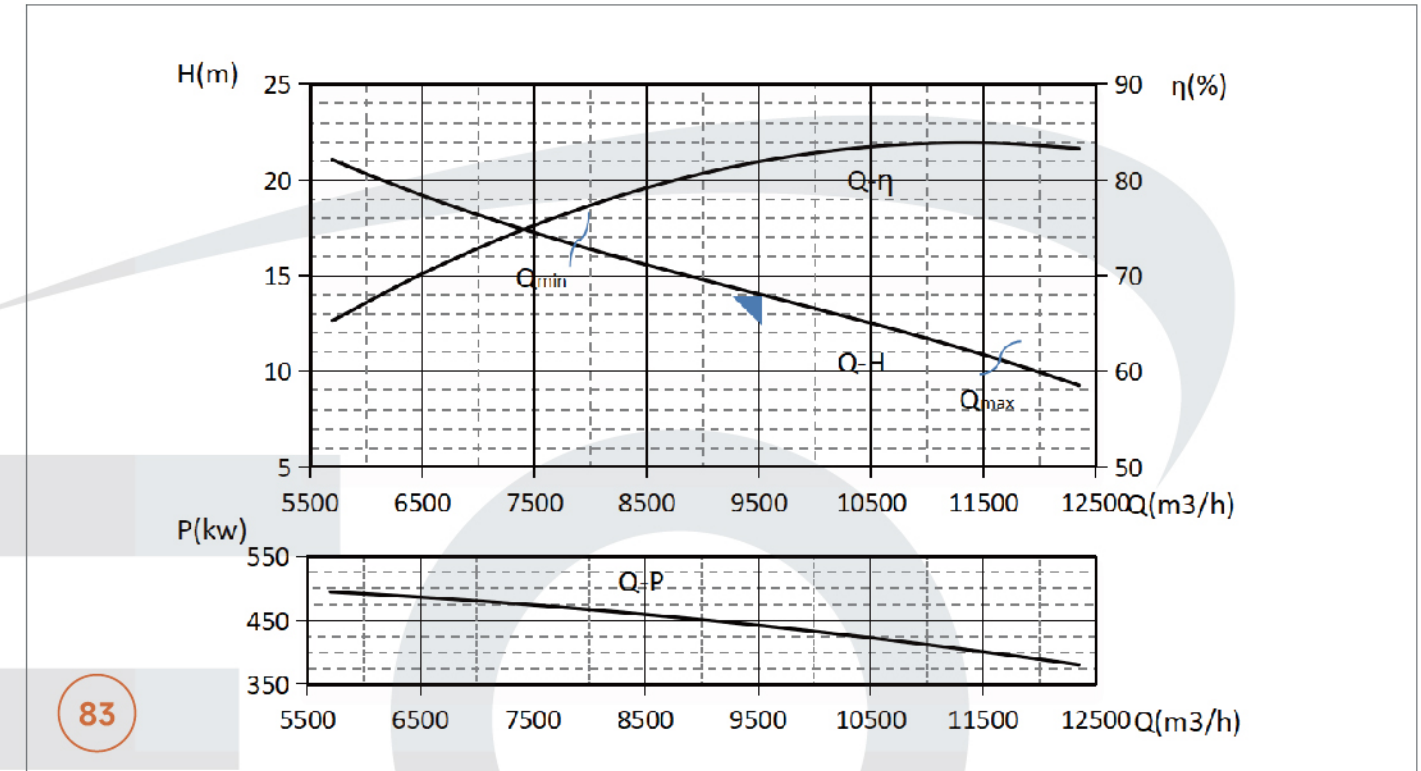

83

900QHD-13 型潜水混流泵性能曲线图 900QHD-13 type submersible Mixed-flow pump performance curve

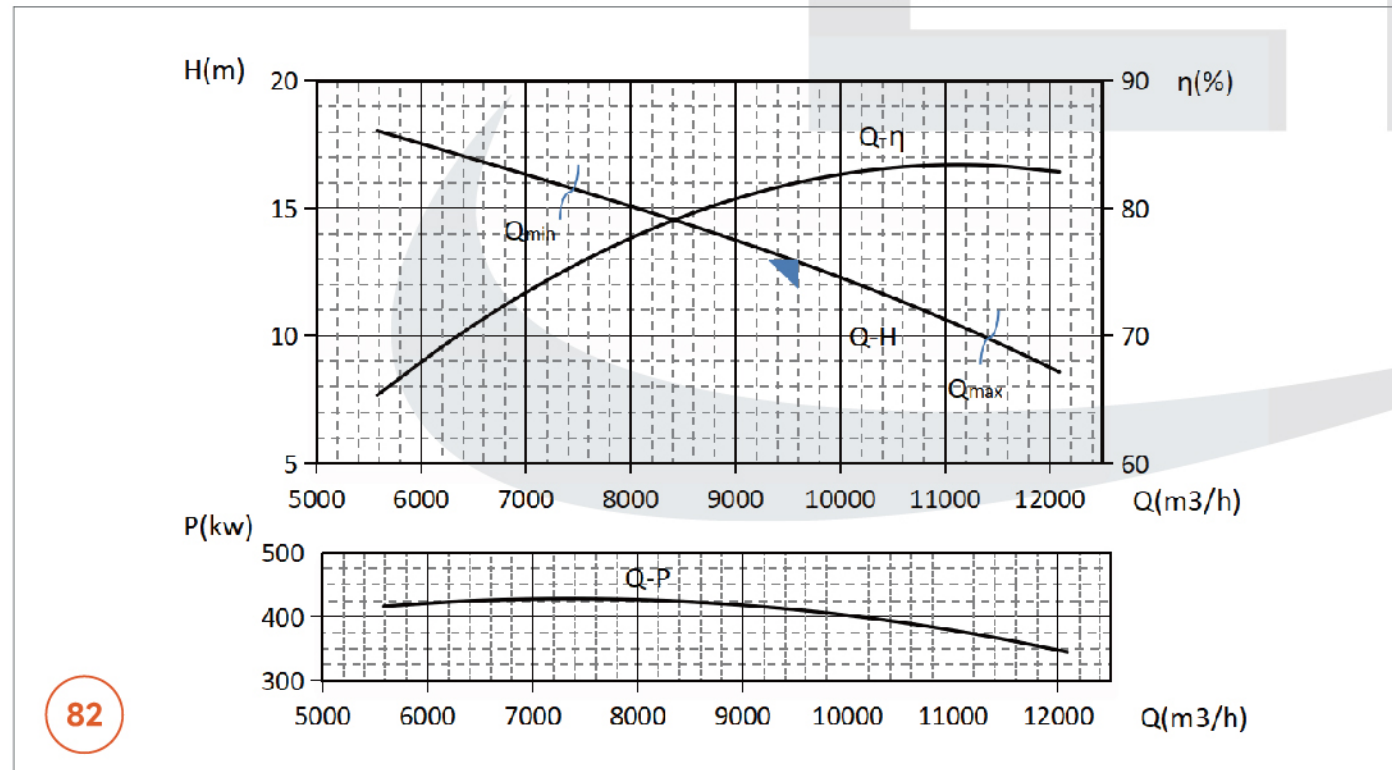

82

900QHD-15 型潜水混流泵性能曲线图 900QHD-15 type submersible Mixed-flow pump performance curve

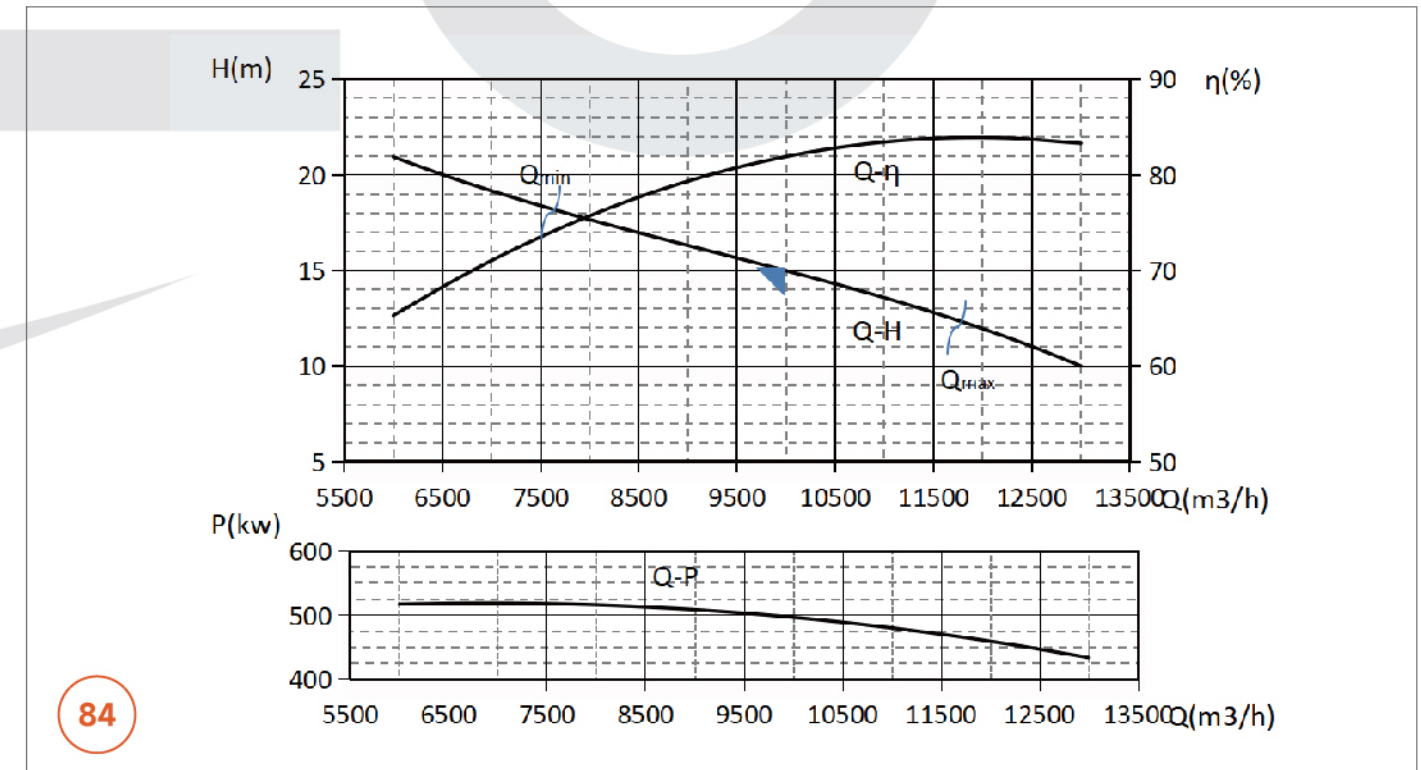

84

性能曲线图 / Performance curve

900QHDX-38 型潜水混流泵性能曲线图 900QHDX-38 type submersible Mixed-flow pump performance curve

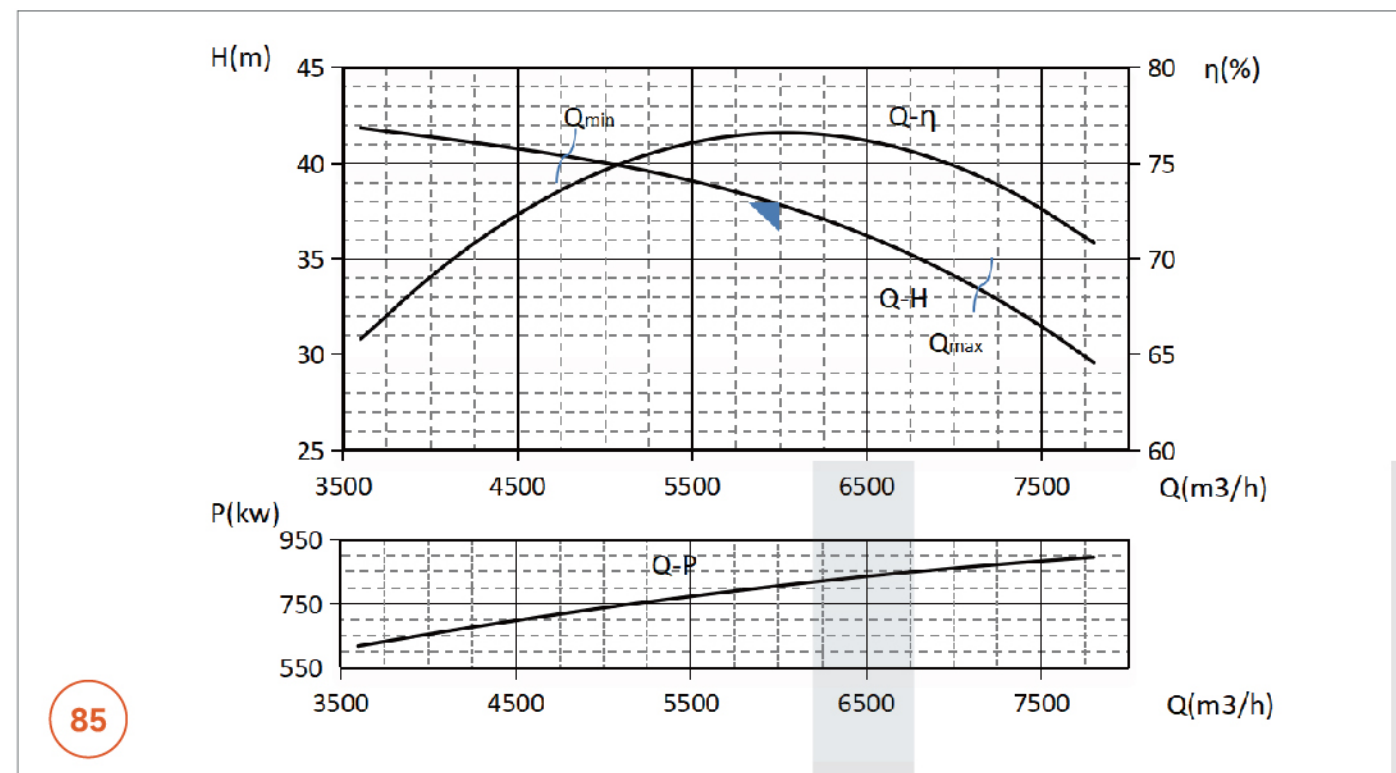

85

性能曲线图 / Performance curve

900QHDX-48 型潜水混流泵性能曲线图 900QHDX-48 type submersible Mixed-flow pump performance curve

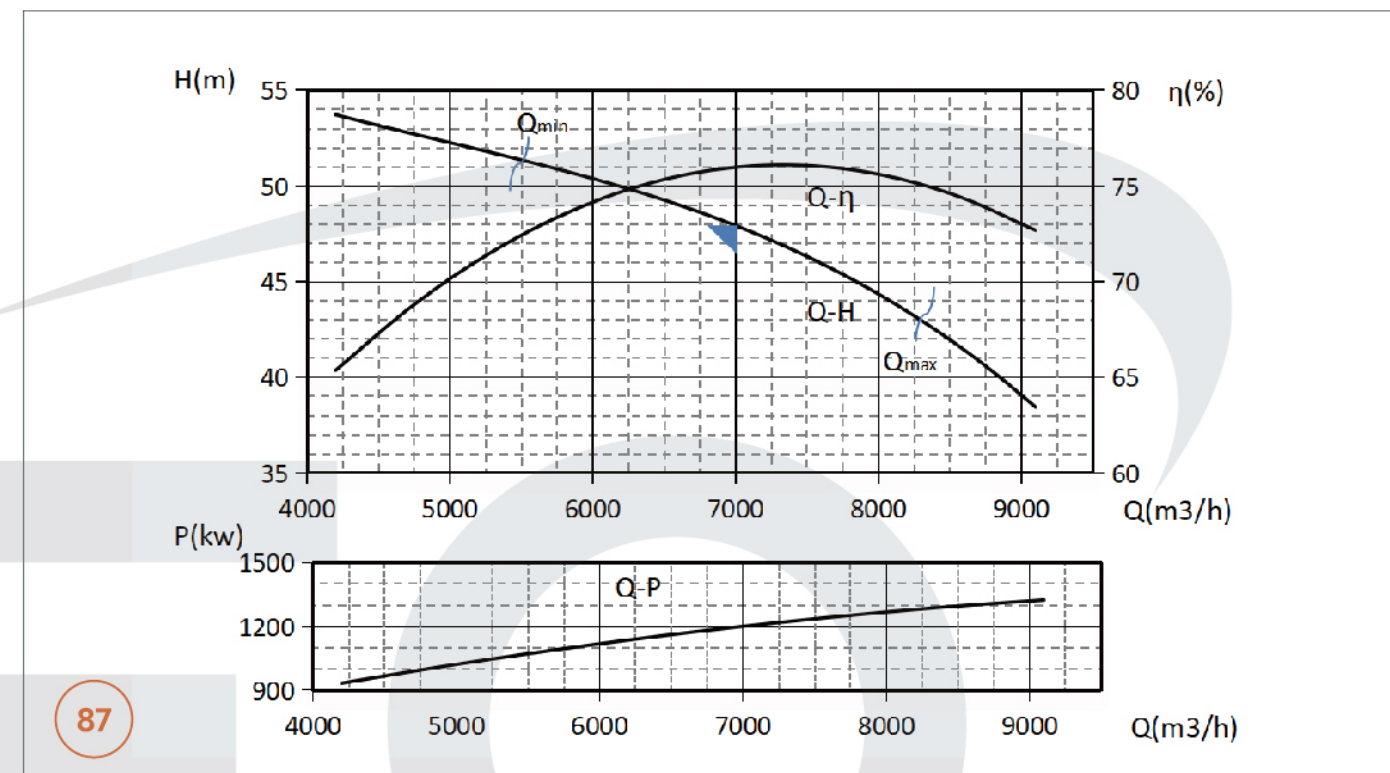

87

900QHDX-43 型潜水混流泵性能曲线图 900QHDX-43 type submersible Mixed-flow pump performance curve

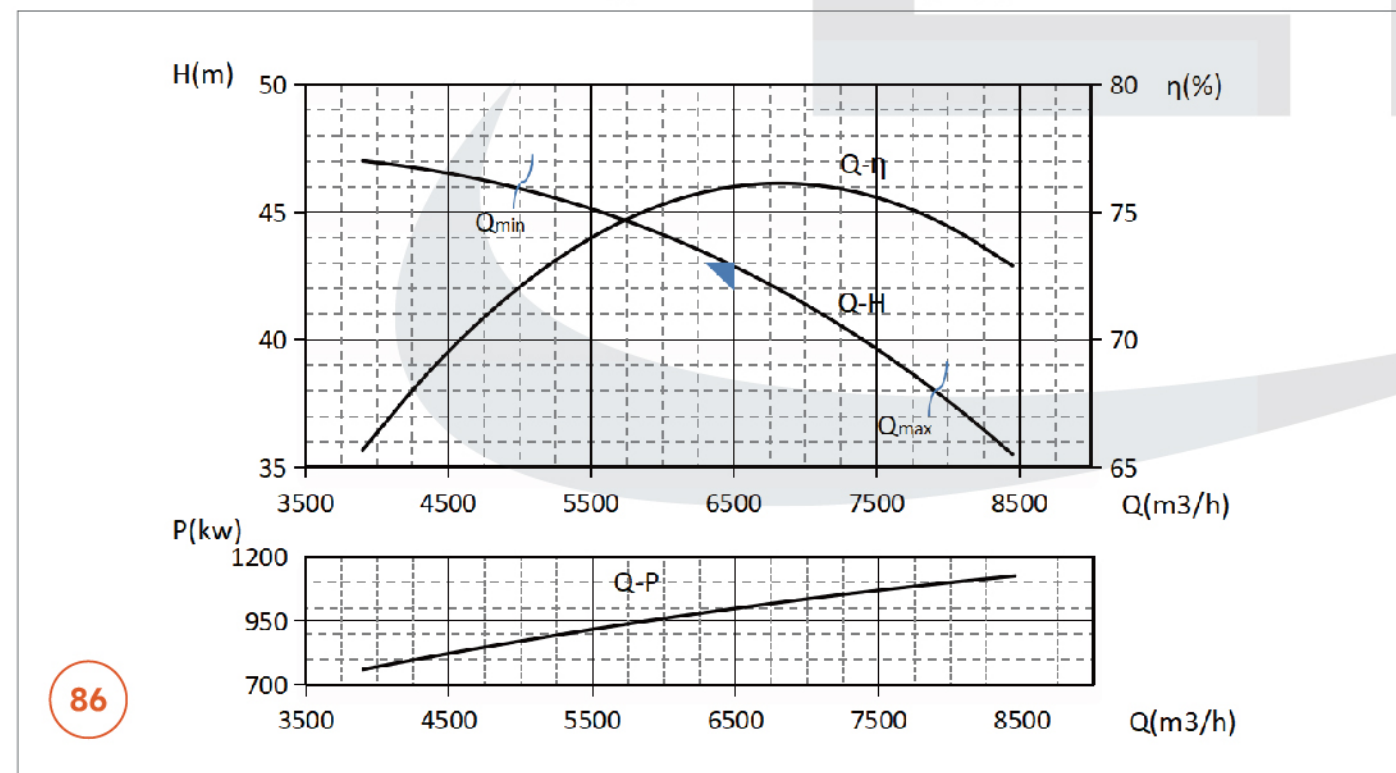

86

1000QHD-8 型潜水混流泵性能曲线图 1000QHD-8 type submersible Mixed-flow pump performance curve

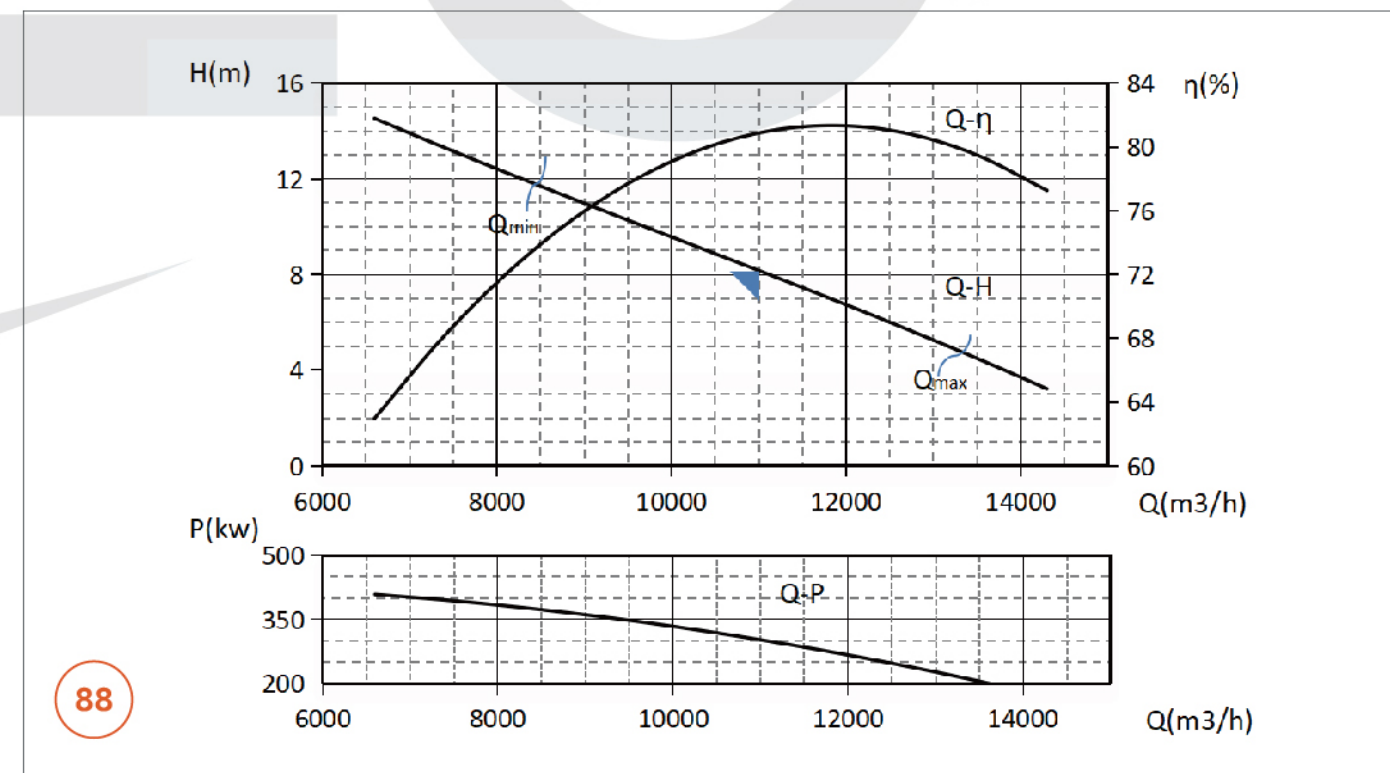

88

性能曲线图 / Performance curve

1000QHD-9 型潜水混流泵性能曲线图 1000QHD-9 type submersible Mixed-flow pump performance curve

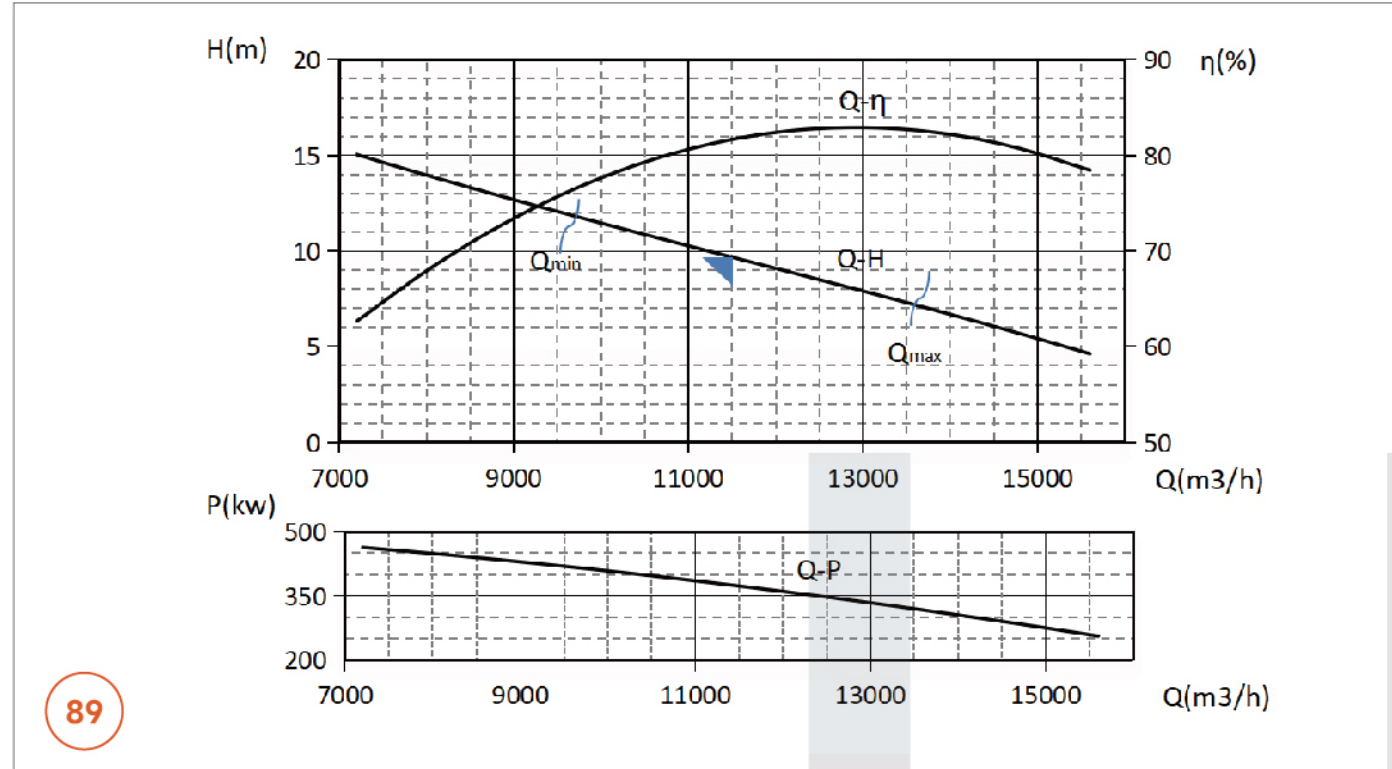

89

性能曲线图 / Performance curve

1000QHD-14 型潜水混流泵性能曲线图 1000QHD-14 type submersible Mixed-flow pump performance curve

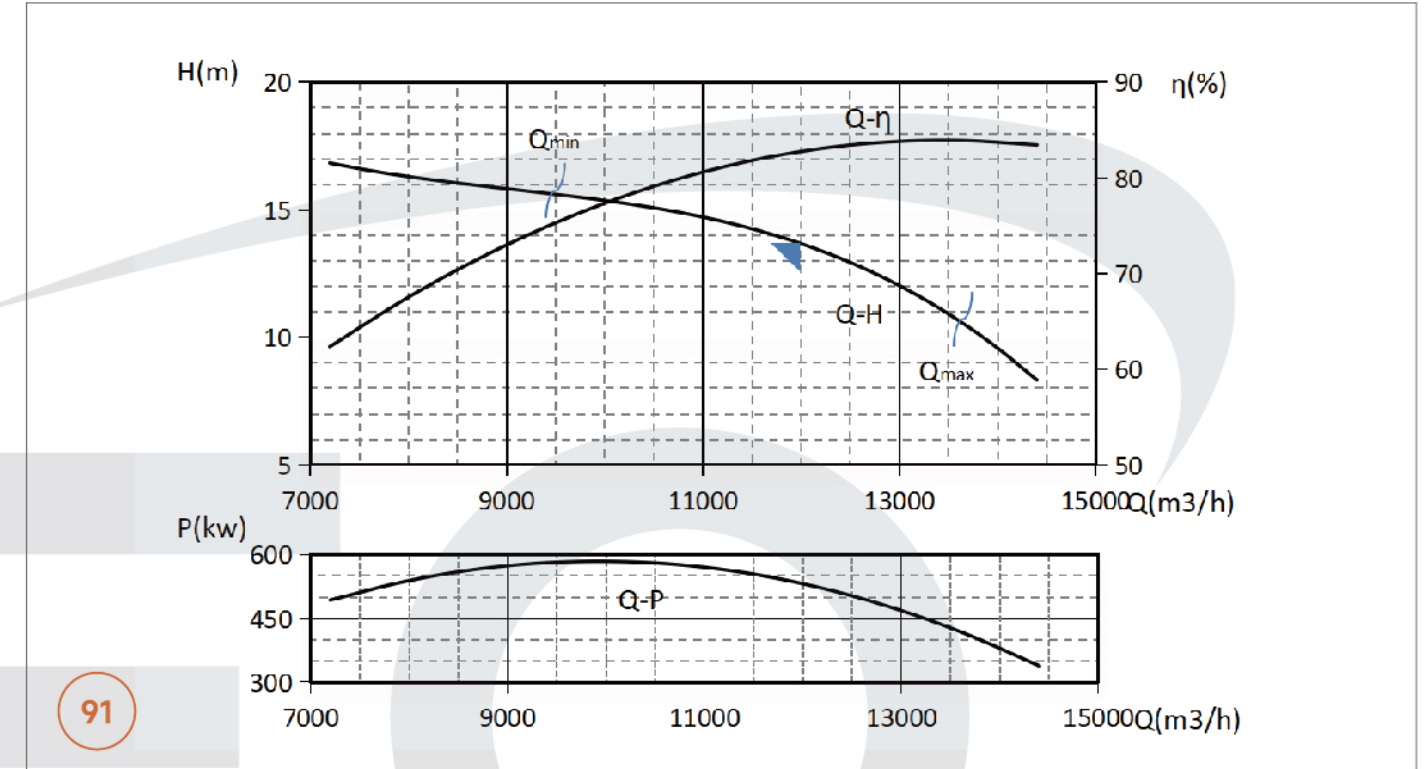

91

1000QHD-10 型潜水混流泵性能曲线图 1000QHD-10 type submersible Mixed-flow pump performance curve

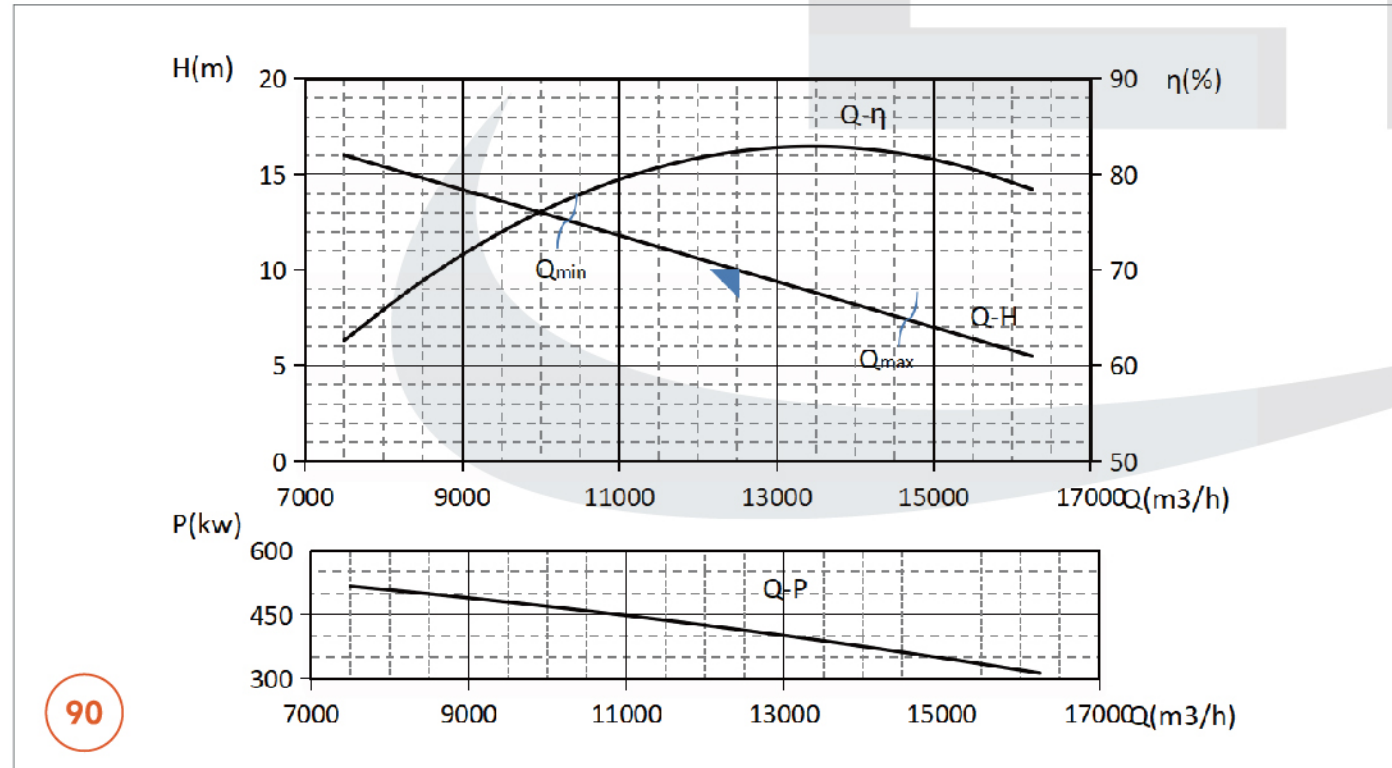

90

1000QHD-15 型潜水混流泵性能曲线图 1000QHD-15 type submersible Mixed-flow pump performance curve

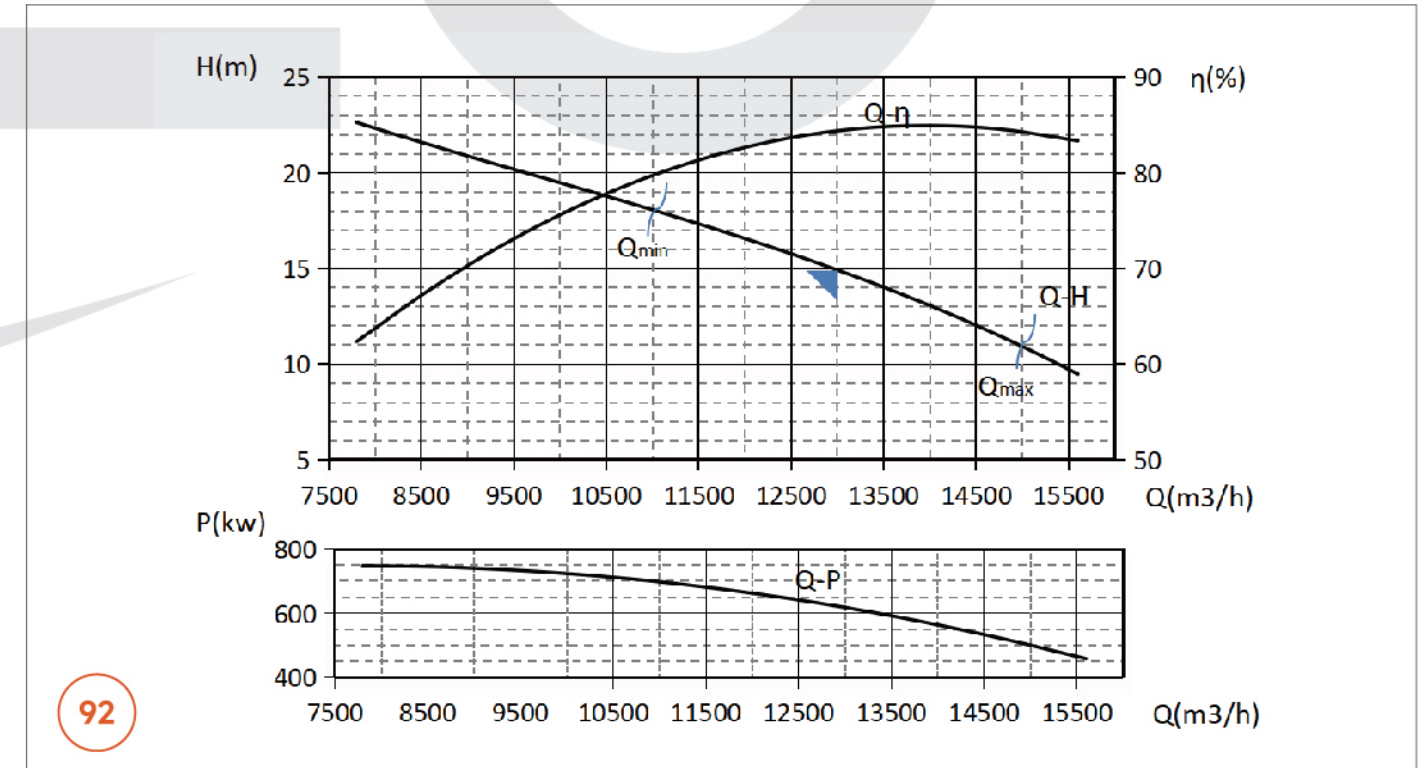

92

性能曲线图 / Performance curve

1000QHD-20 型潜水混流泵性能曲线图 1000QHD-20 type submersible Mixed-flow pump performance curve

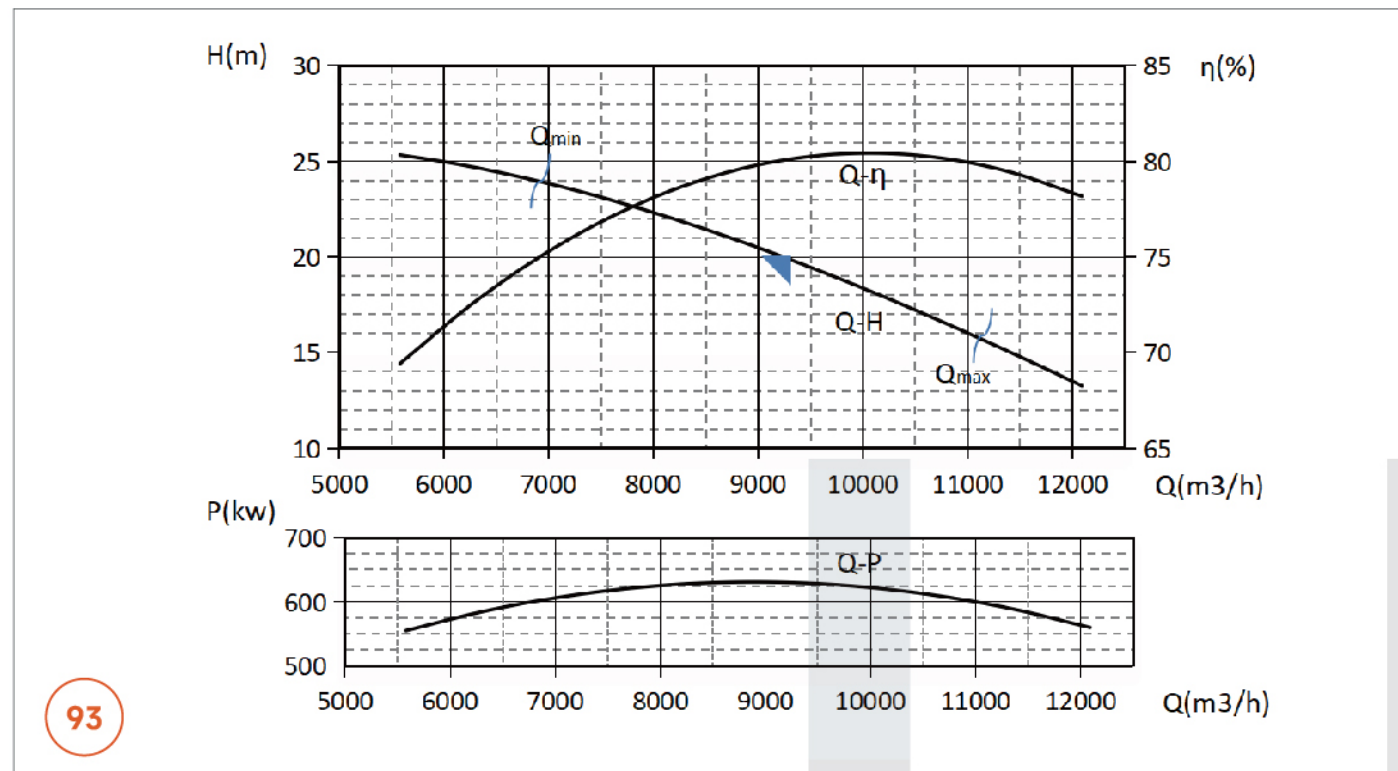

93

性能曲线图 / Performance curve

1000QHDX-26 型潜水混流泵性能曲线图 1000QHDX-26 type submersible Mixed-flow pump performance curve

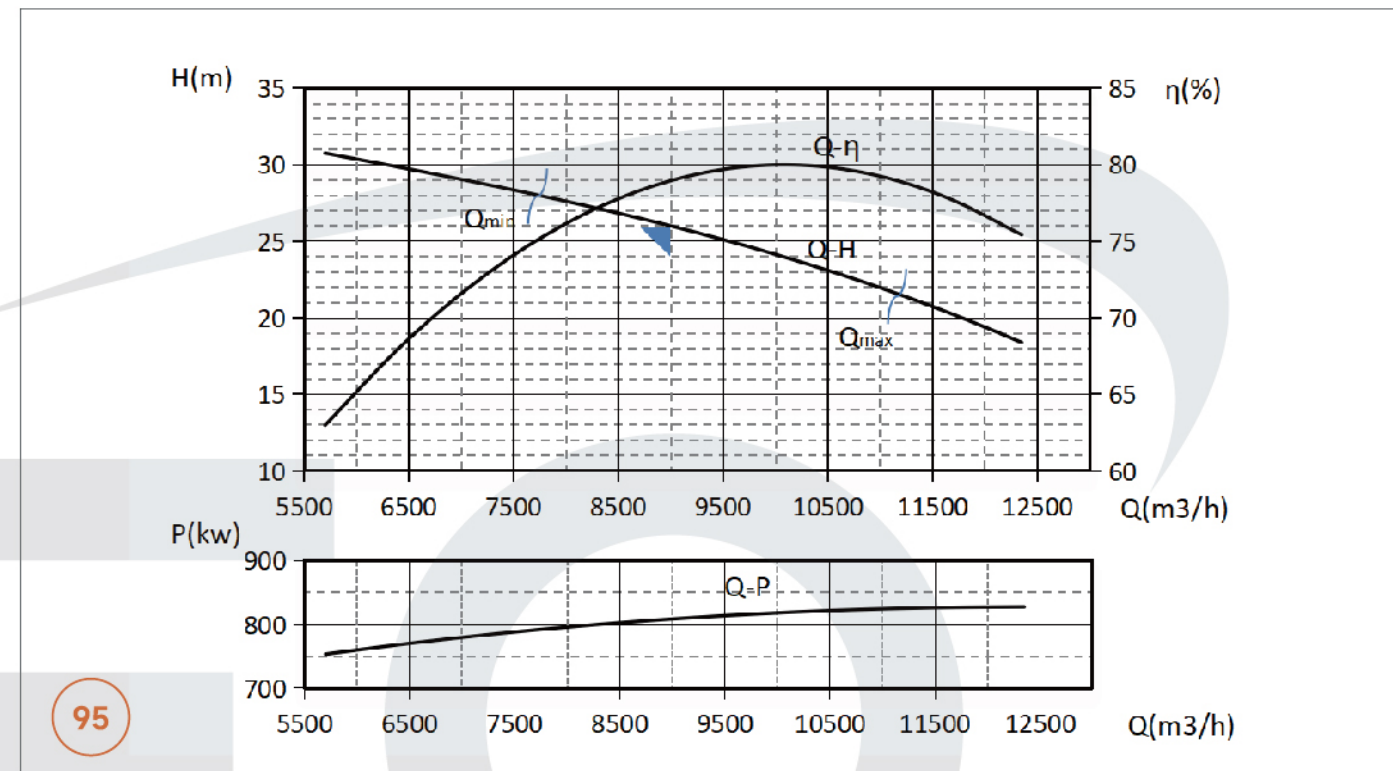

95

1000QHD-22 型潜水混流泵性能曲线图 1000QHD-22 type submersible Mixed-flow pump performance curve

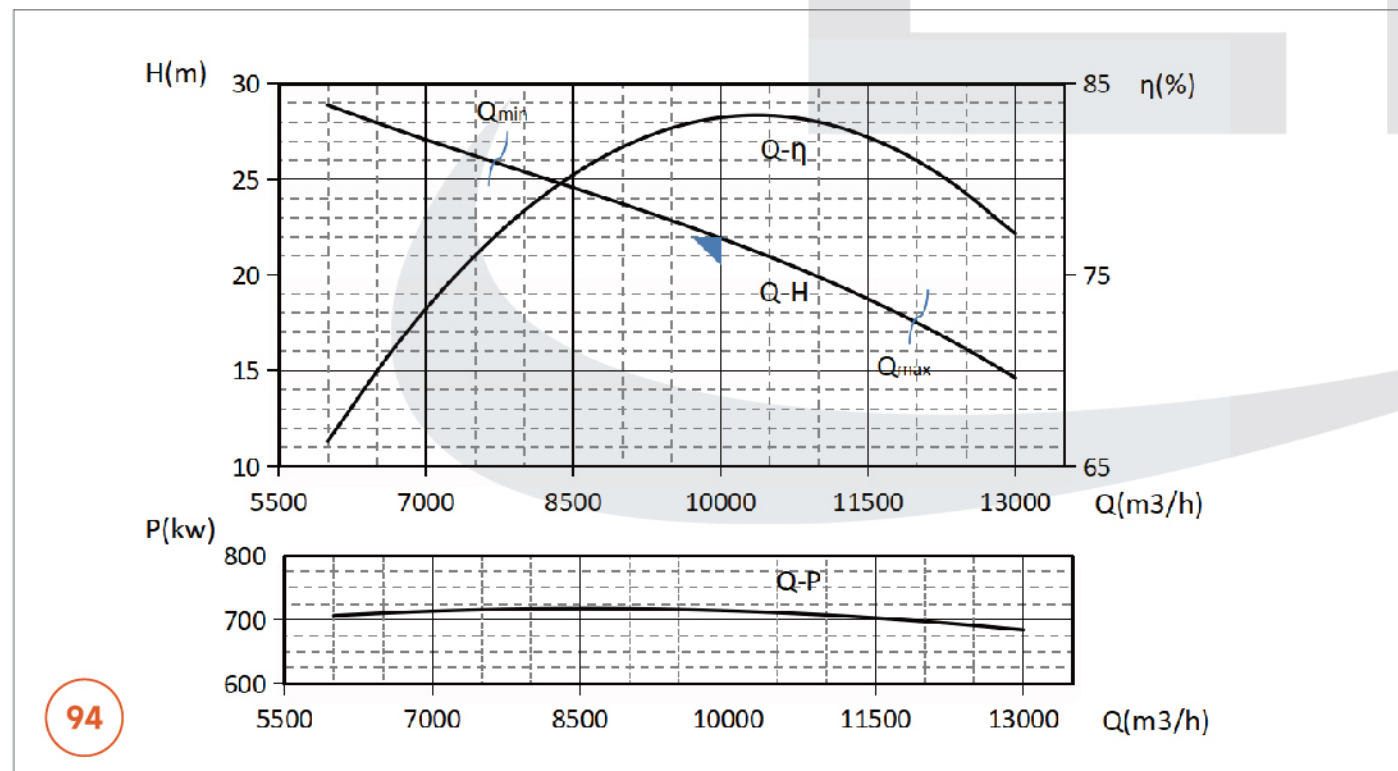

94

1000QHDX-29 型潜水混流泵性能曲线图 1000QHDX-29 type submersible Mixed-flow pump performance curve

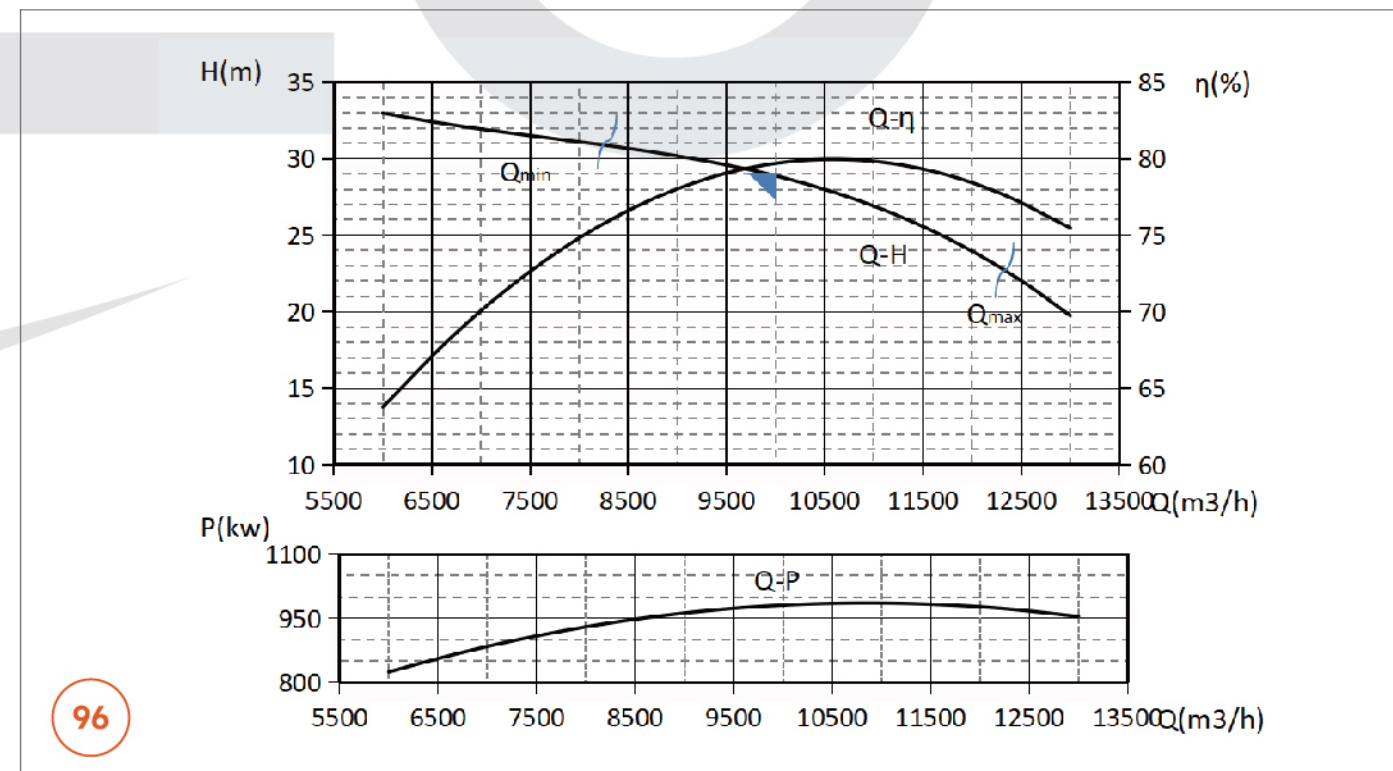

96

性能曲线图 / Performance curve

1000QHDX-35 型潜水混流泵性能曲线图 1000QHDX-35 type submersible Mixed-flow pump performance curve

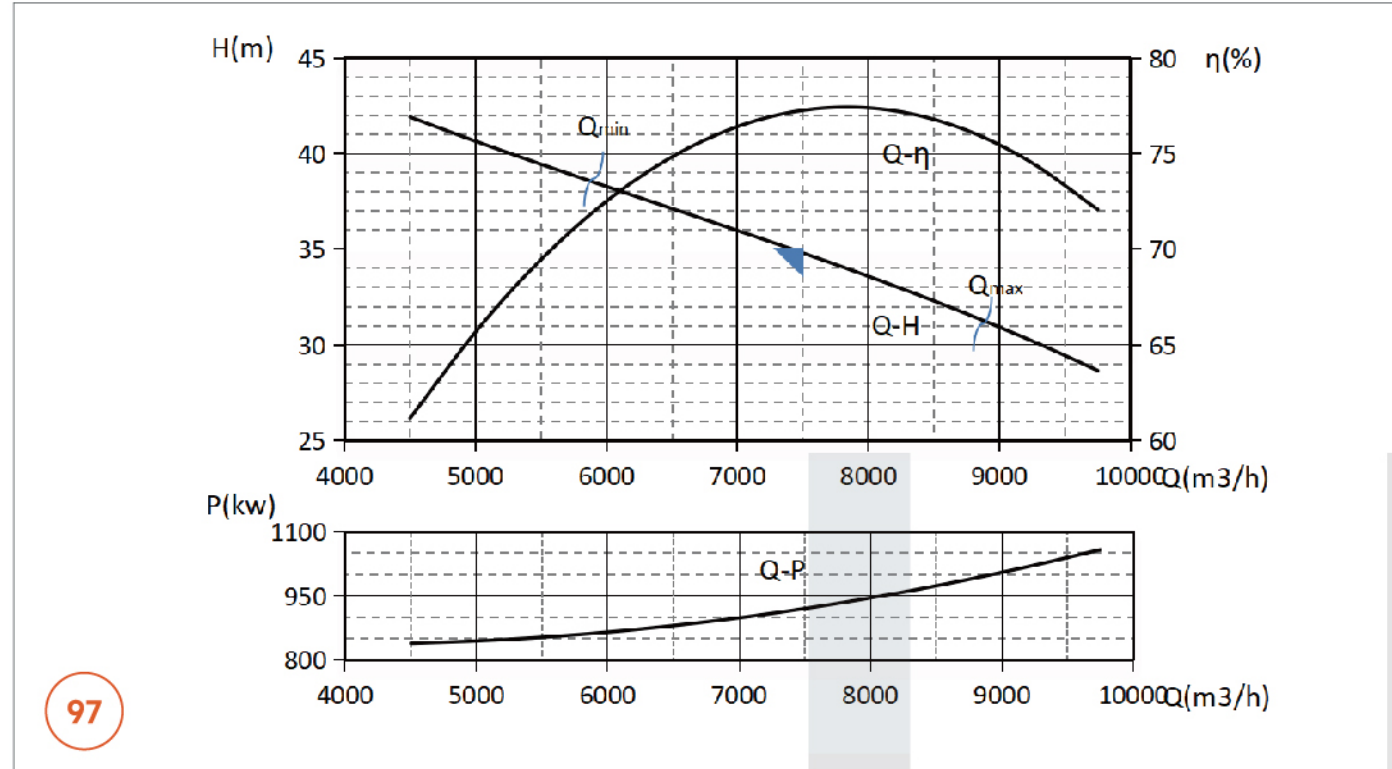

97

性能曲线图 / Performance curve

1200QHD-8.5 型潜水混流泵性能曲线图 1200QHD-8.5 type submersible Mixed-flow pump performance curve

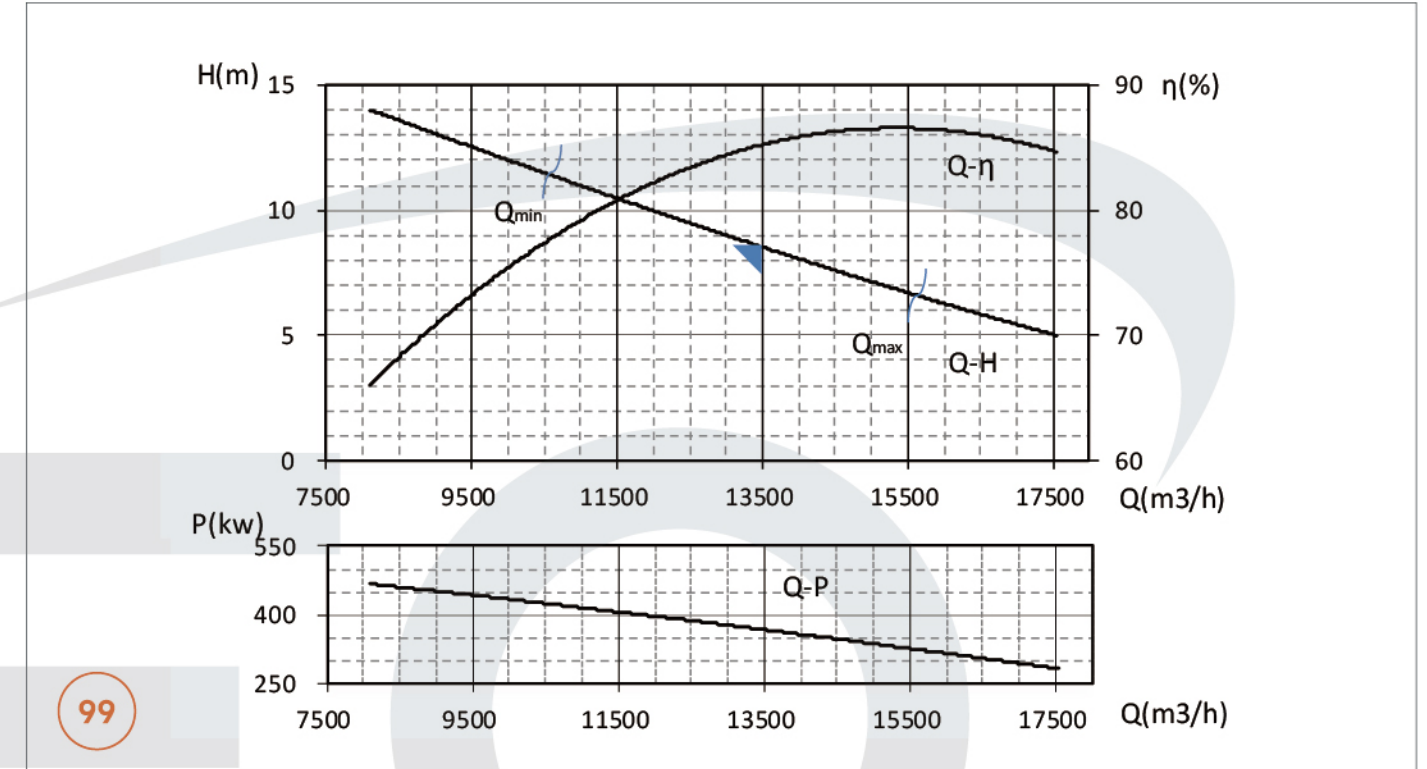

99

1000QHDX-39 型潜水混流泵性能曲线图 1000QHDX-39 type submersible Mixed-flow pump performance curve

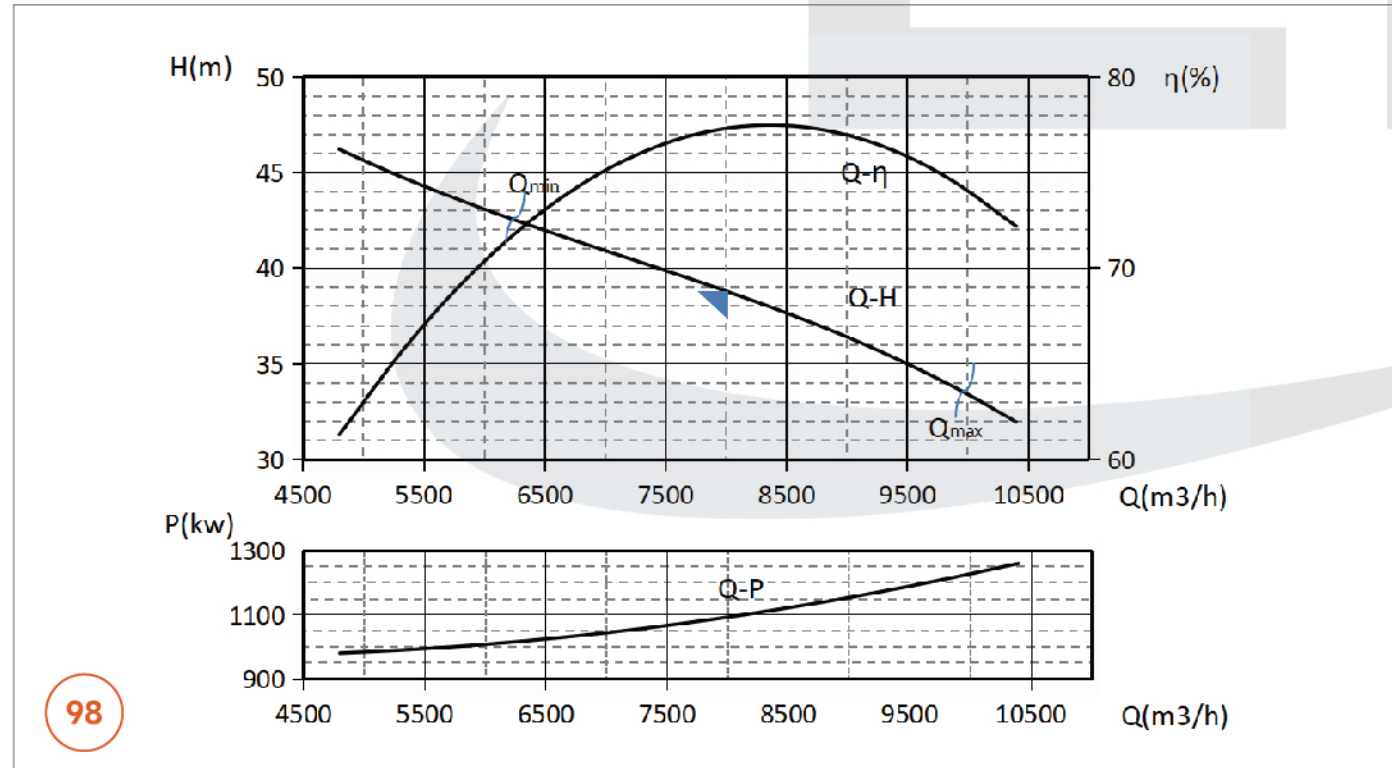

98

1200QHD-10 型潜水混流泵性能曲线图 1200QHD-10 type submersible Mixed-flow pump performance curve

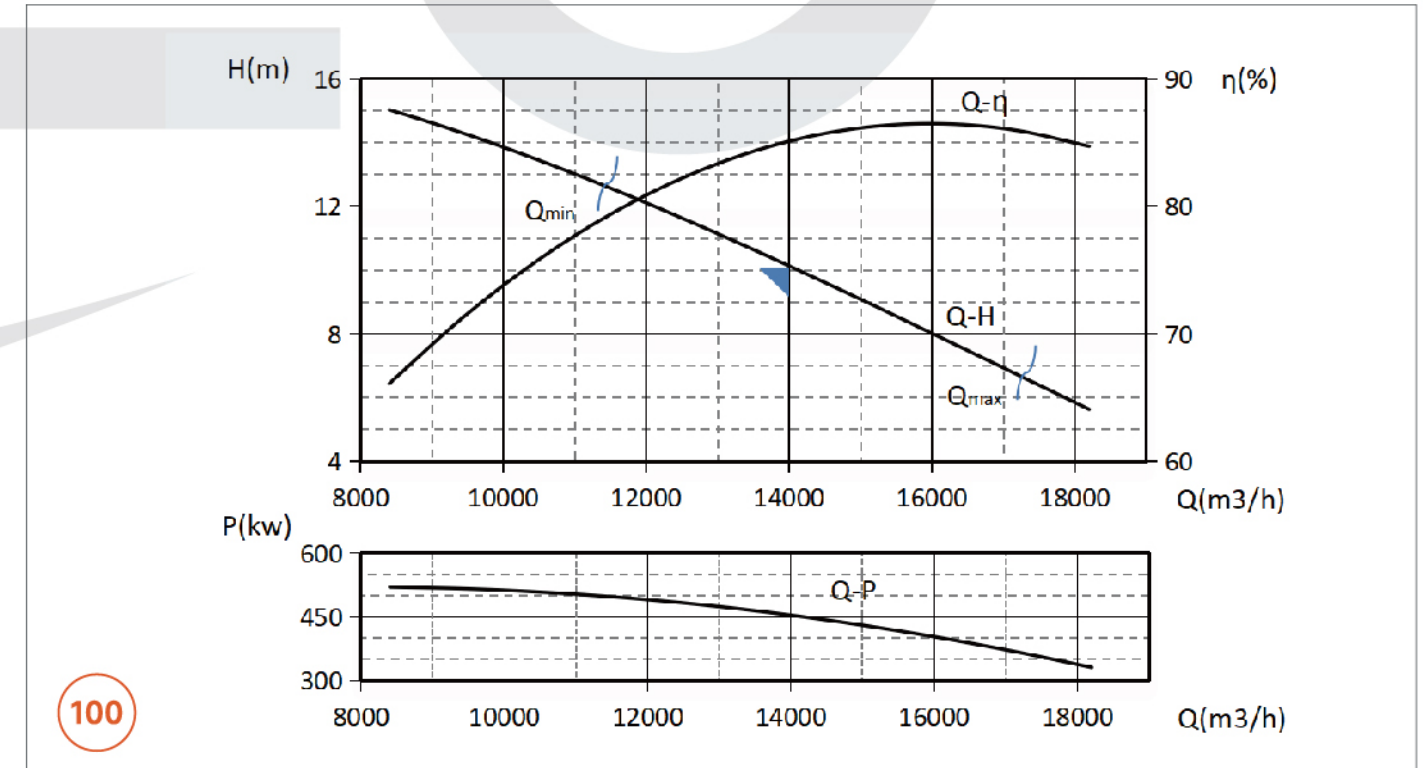

100

性能曲线图 / Performance curve

1200QHD-11 型潜水混流泵性能曲线图 1200QHD-11 type submersible Mixed-flow pump performance curve

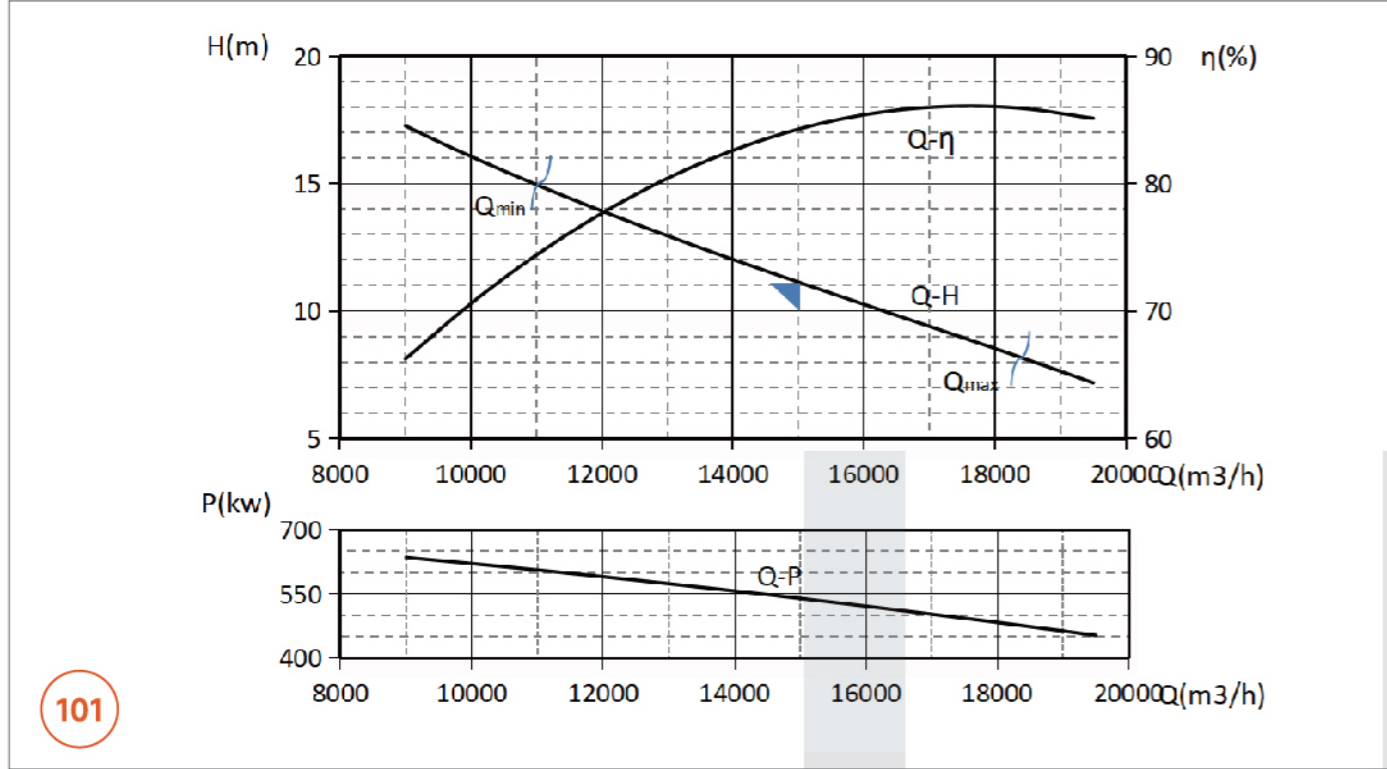

101

性能曲线图 / Performance curve

1200QHD-19 型潜水混流泵性能曲线图 1200QHD-19 type submersible Mixed-flow pump performance curve

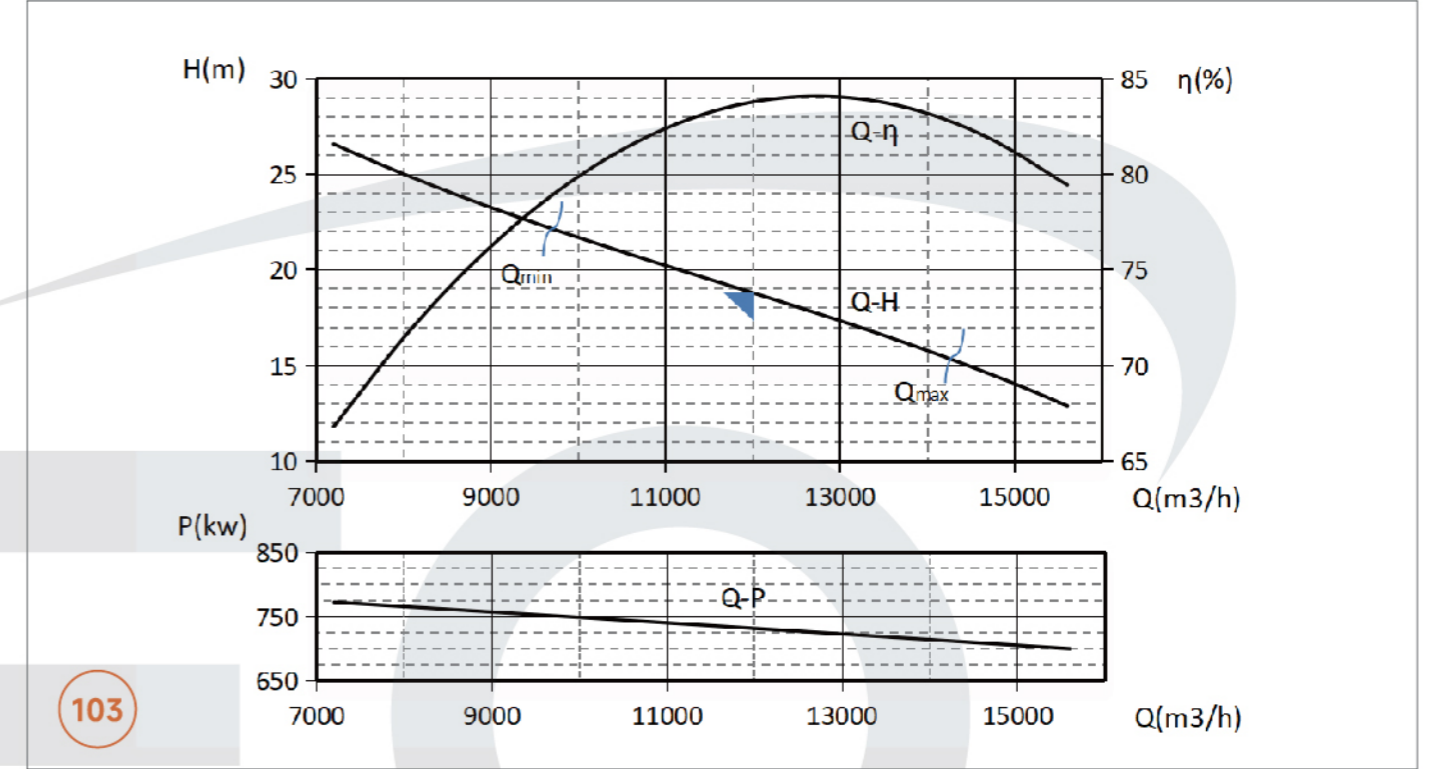

103

1200QHD-12 型潜水混流泵性能曲线图 1200QHD-12 type submersible Mixed-flow pump performance curve

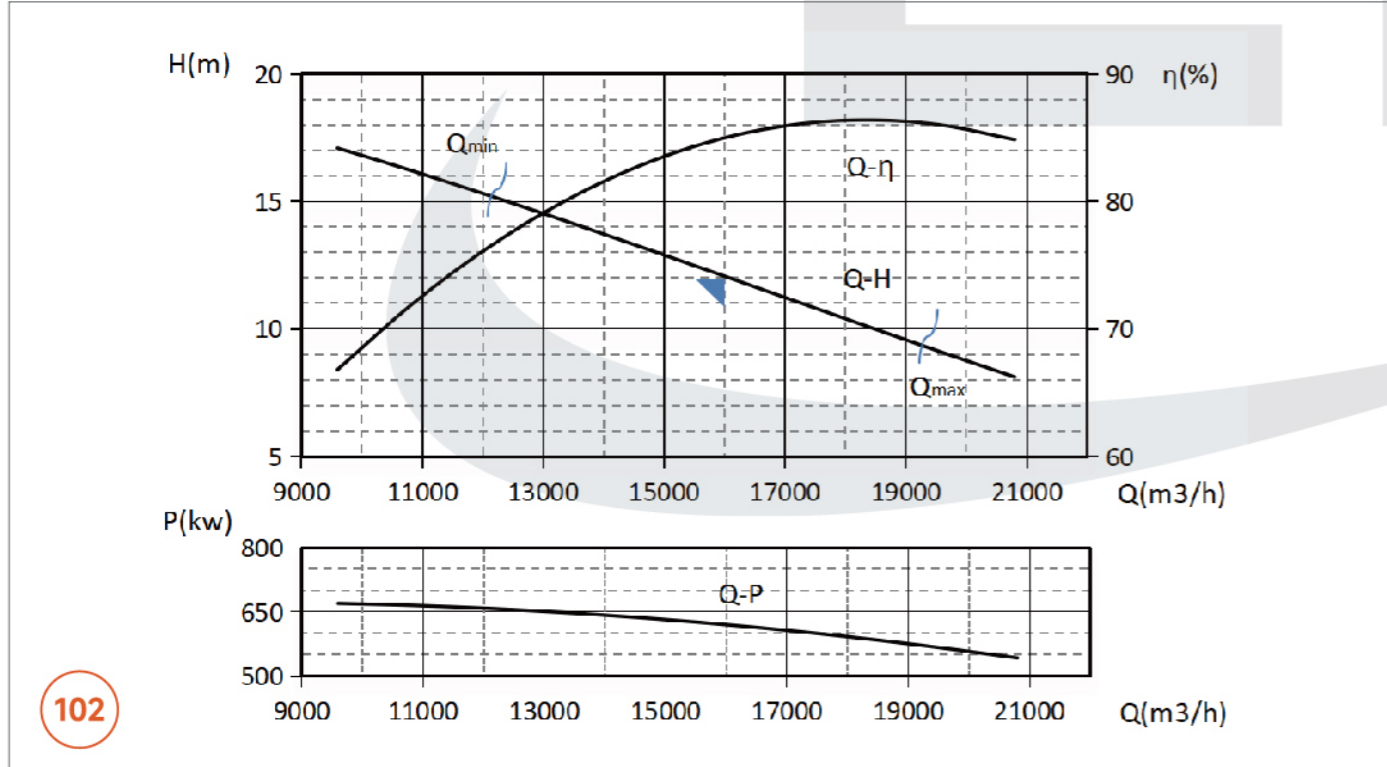

102

1200QHD-21 型潜水混流泵性能曲线图 1200QHD-21 type submersible Mixed-flow pump performance curve

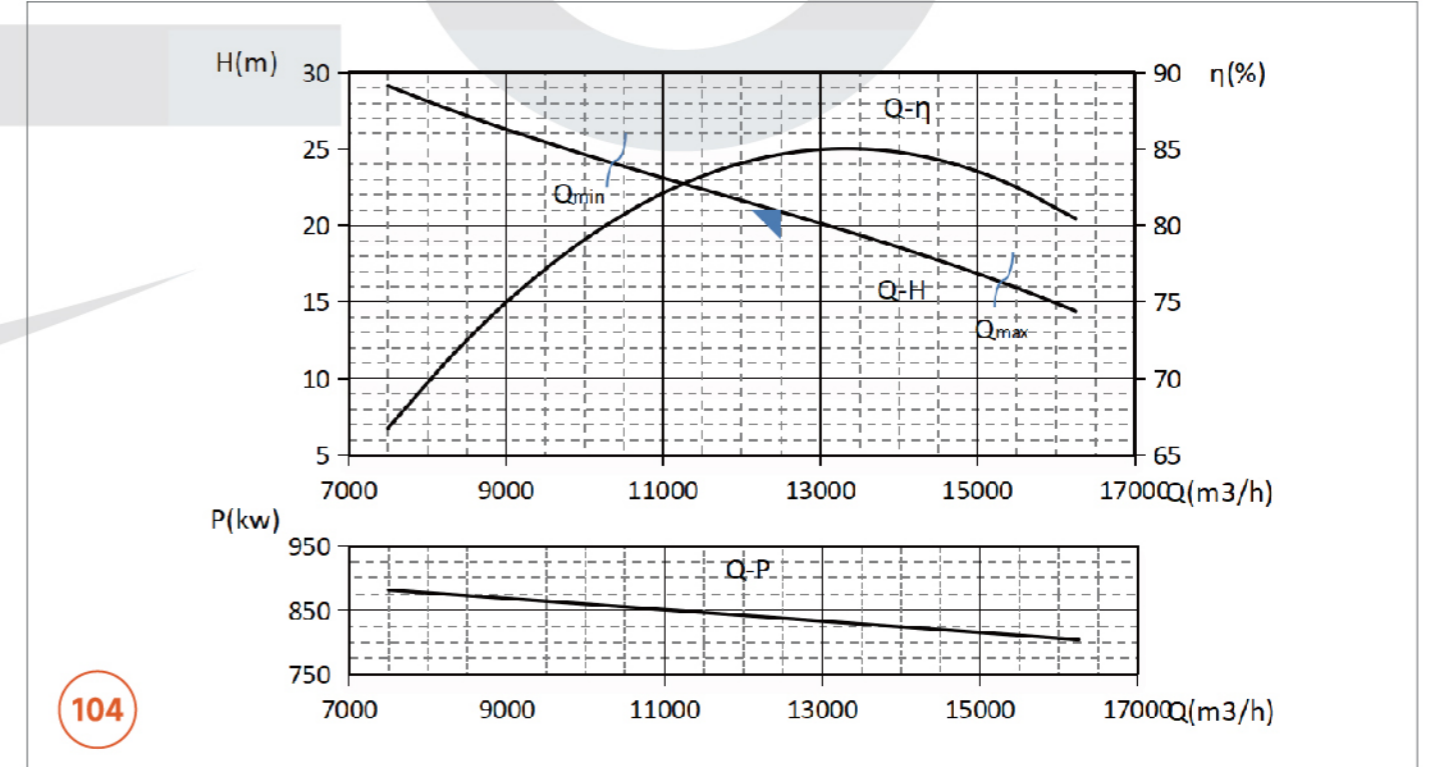

104

性能曲线图 / Performance curve

1200QHDX-22 型潜水混流泵性能曲线图 1200QHDX-22 type submersible Mixed-flow pump performance curve

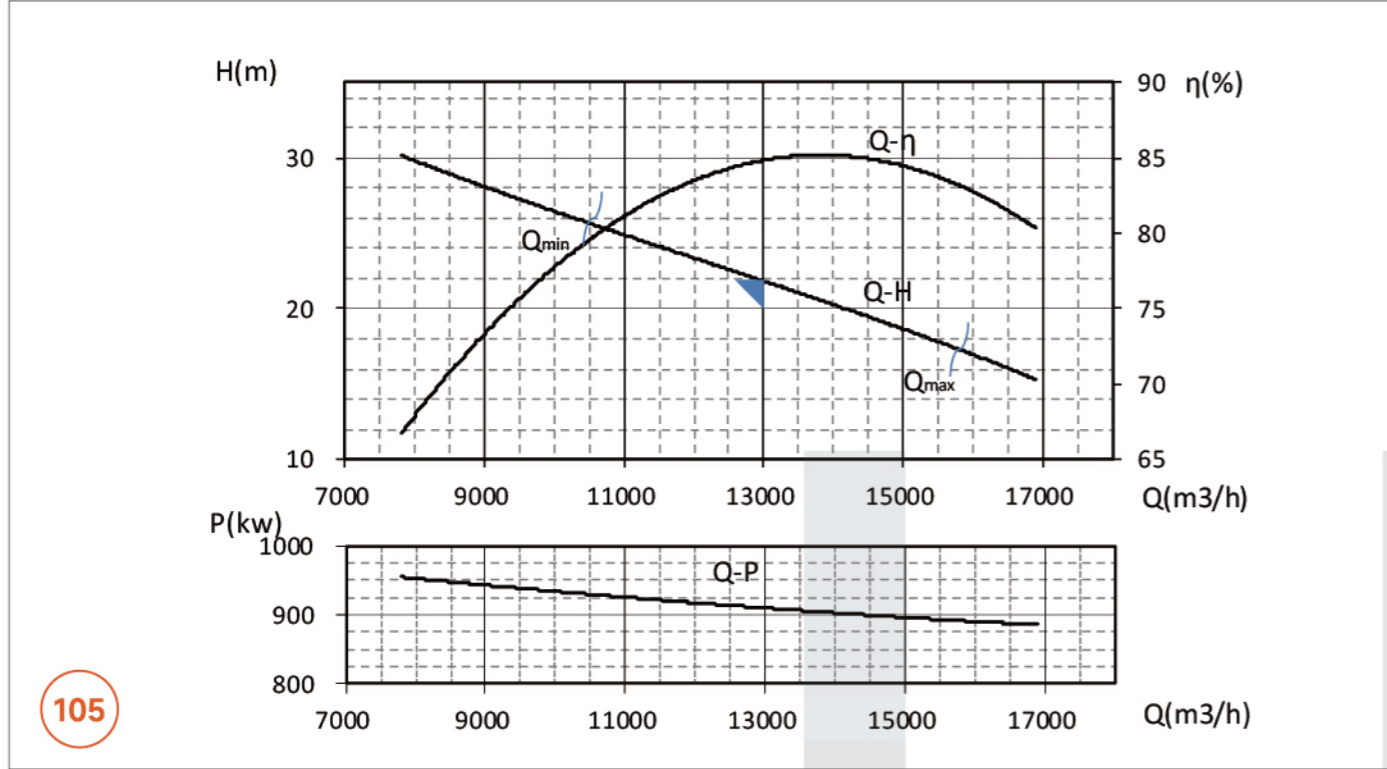

105

性能曲线图 / Performance curve

1200QHDX-30 型潜水混流泵性能曲线图 1200QHDX-30 type submersible Mixed-flow pump performance curve

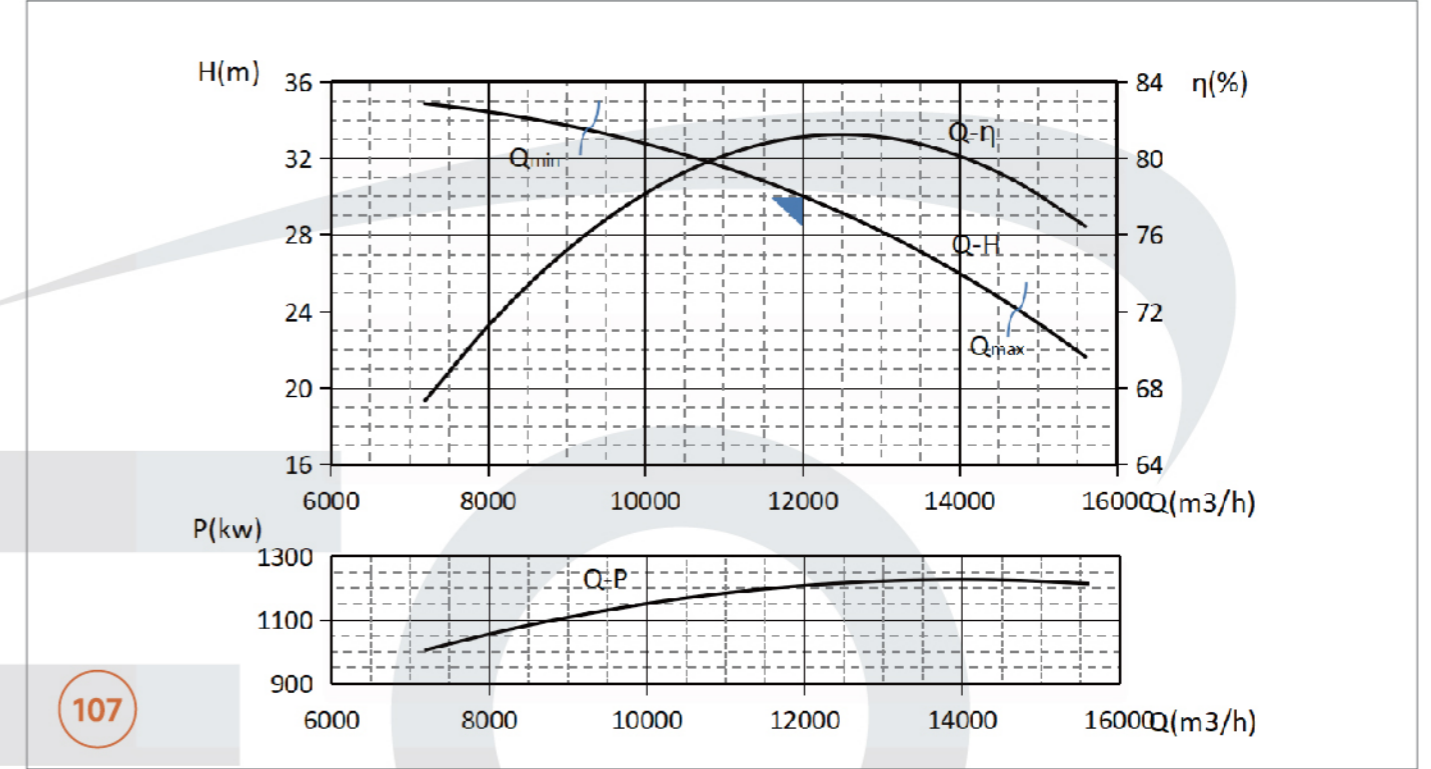

107

1200QHDX-28 型潜水混流泵性能曲线图 1200QHDX-28 type submersible Mixed-flow pump performance curve

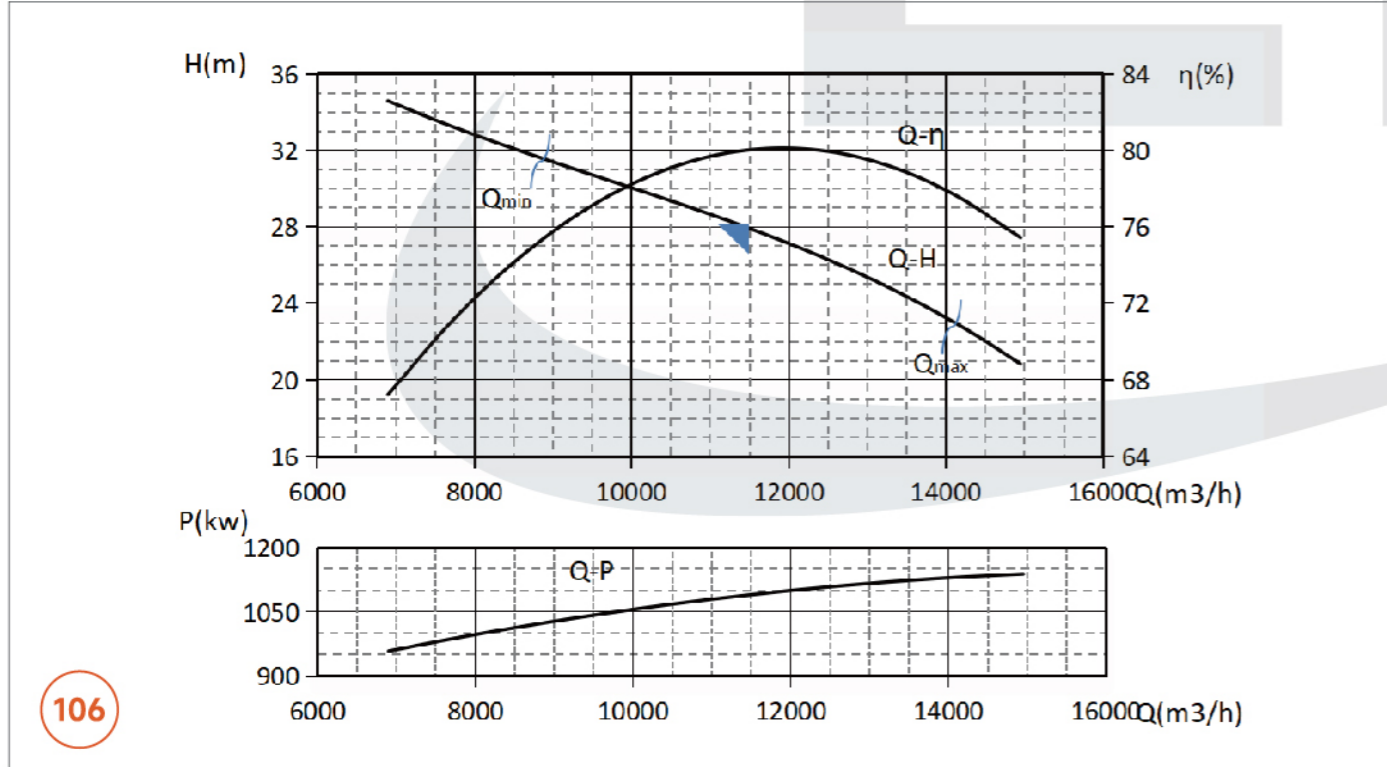

106

1400QHDX-12.5 型潜水混流泵性能曲线图 1400QHDX-12.5 type submersible Mixed-flow pump performance curve

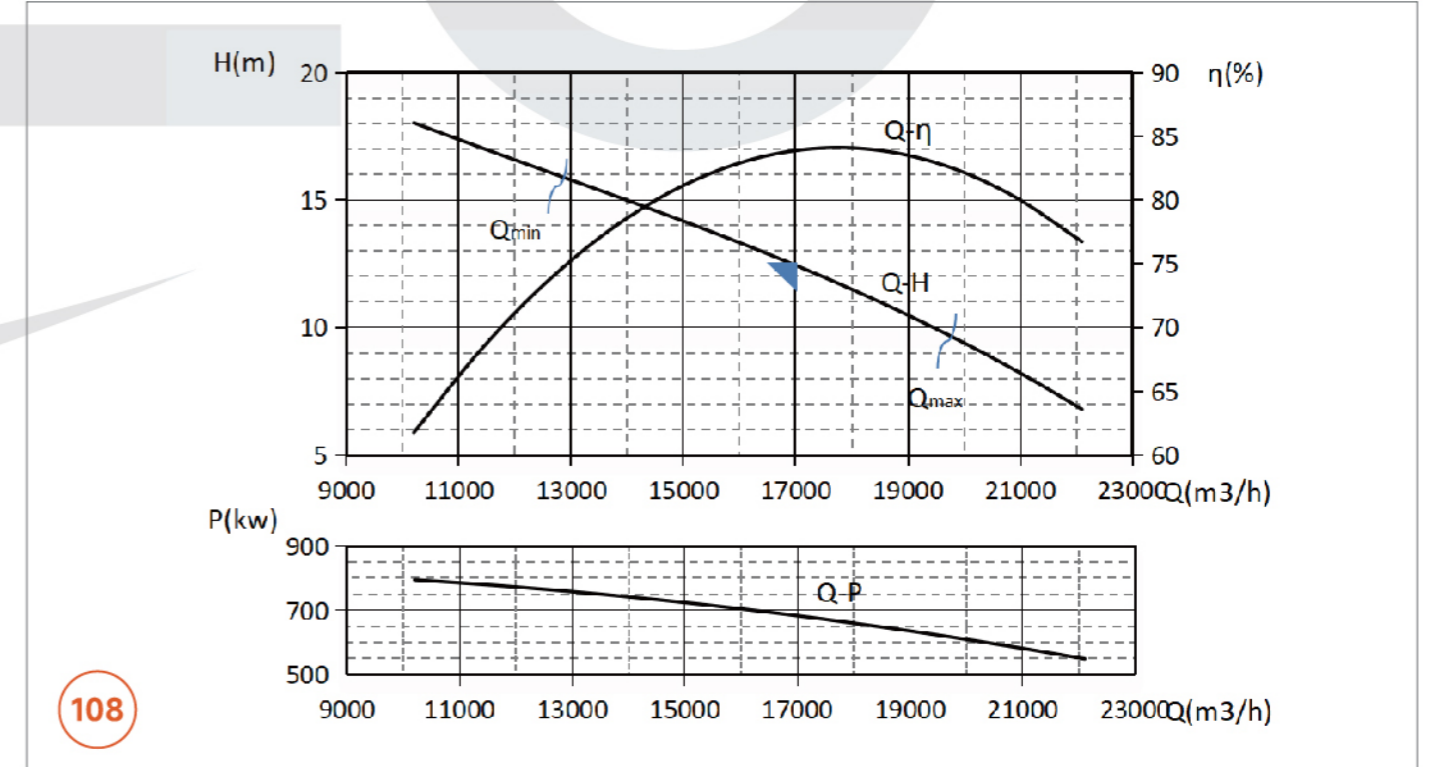

108

性能曲线图 / Performance curve

1400QHDX-13 型潜水混流泵性能曲线图 1400QHDX-13 type submersible Mixed-flow pump performance curve

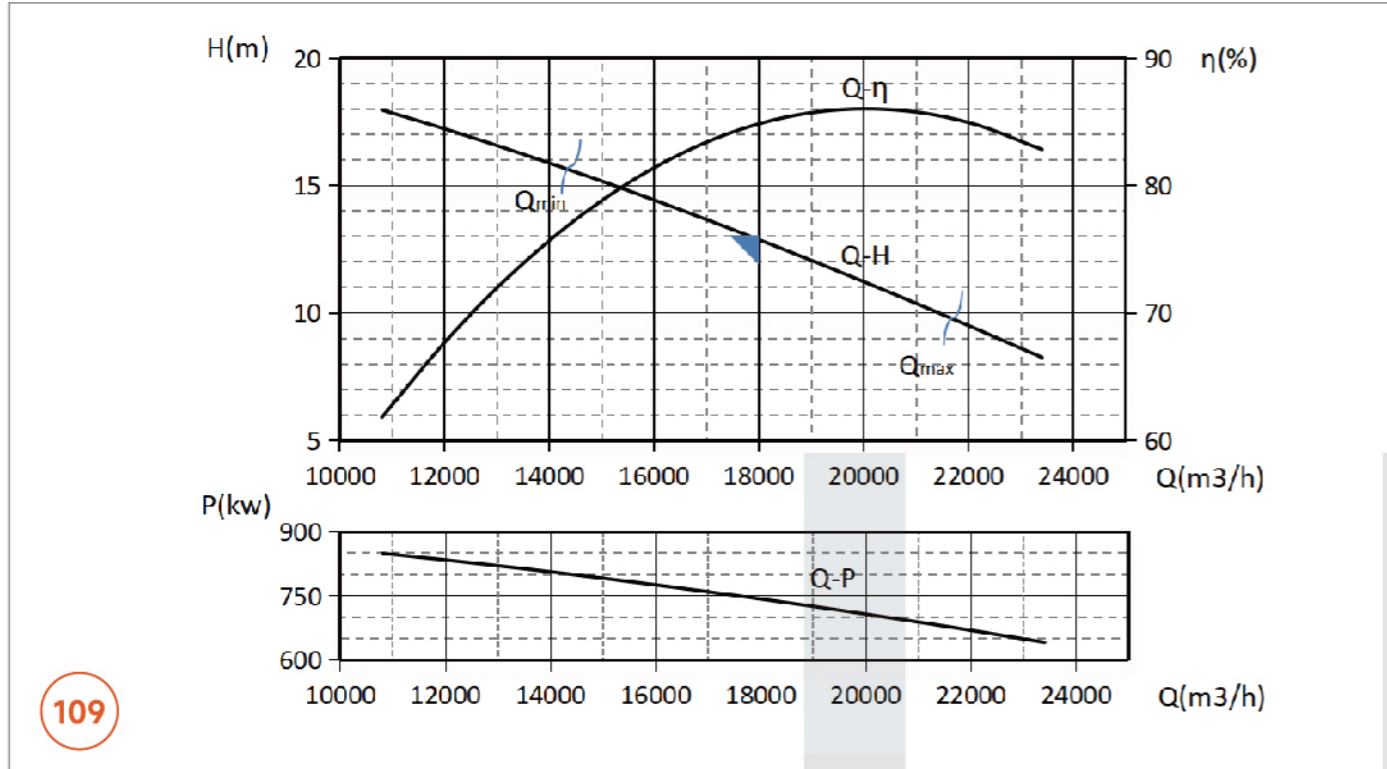

109

性能曲线图 / Performance curve

1400QHDX-15 型潜水混流泵性能曲线图 1400QHDX-15 type submersible Mixed-flow pump performance curve

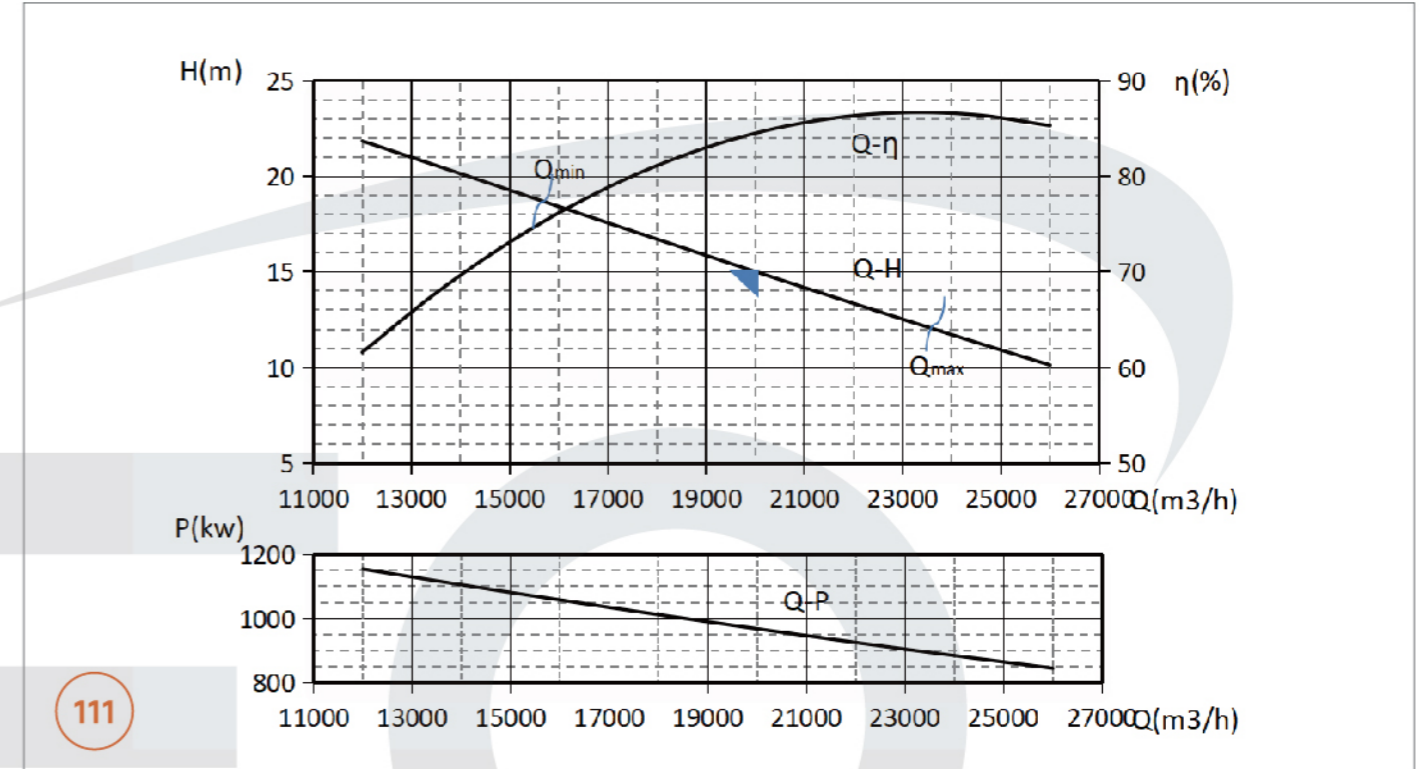

111

1400QHDX-14 型潜水混流泵性能曲线图 1400QHDX-14 type submersible Mixed-flow pump performance curve

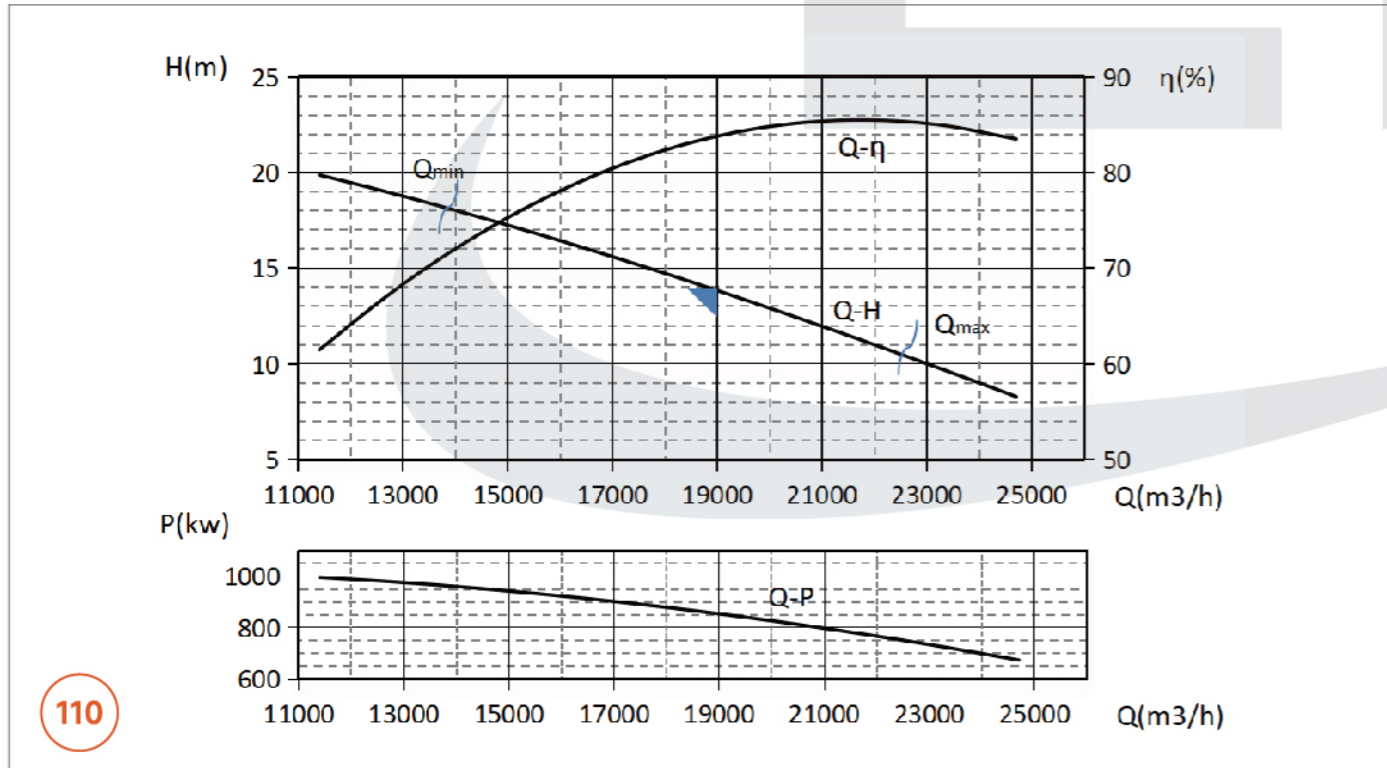

110

1400QHDX-16 型潜水混流泵性能曲线图 1400QHDX-16 type submersible Mixed-flow pump performance curve

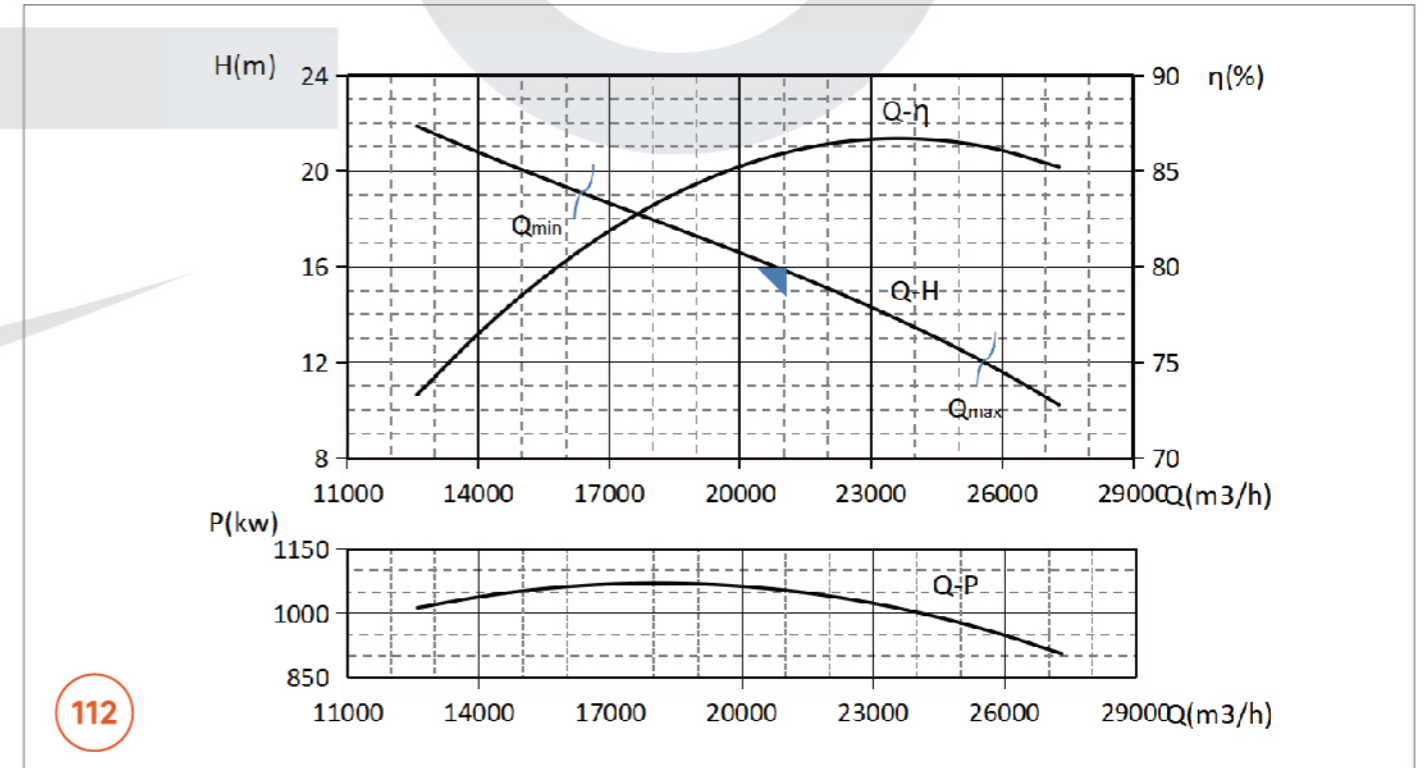

112

性能曲线图 / Performance curve

1400QHDX-18 型潜水混流泵性能曲线图 1400QHDX-18 type submersible Mixed-flow pump performance curve

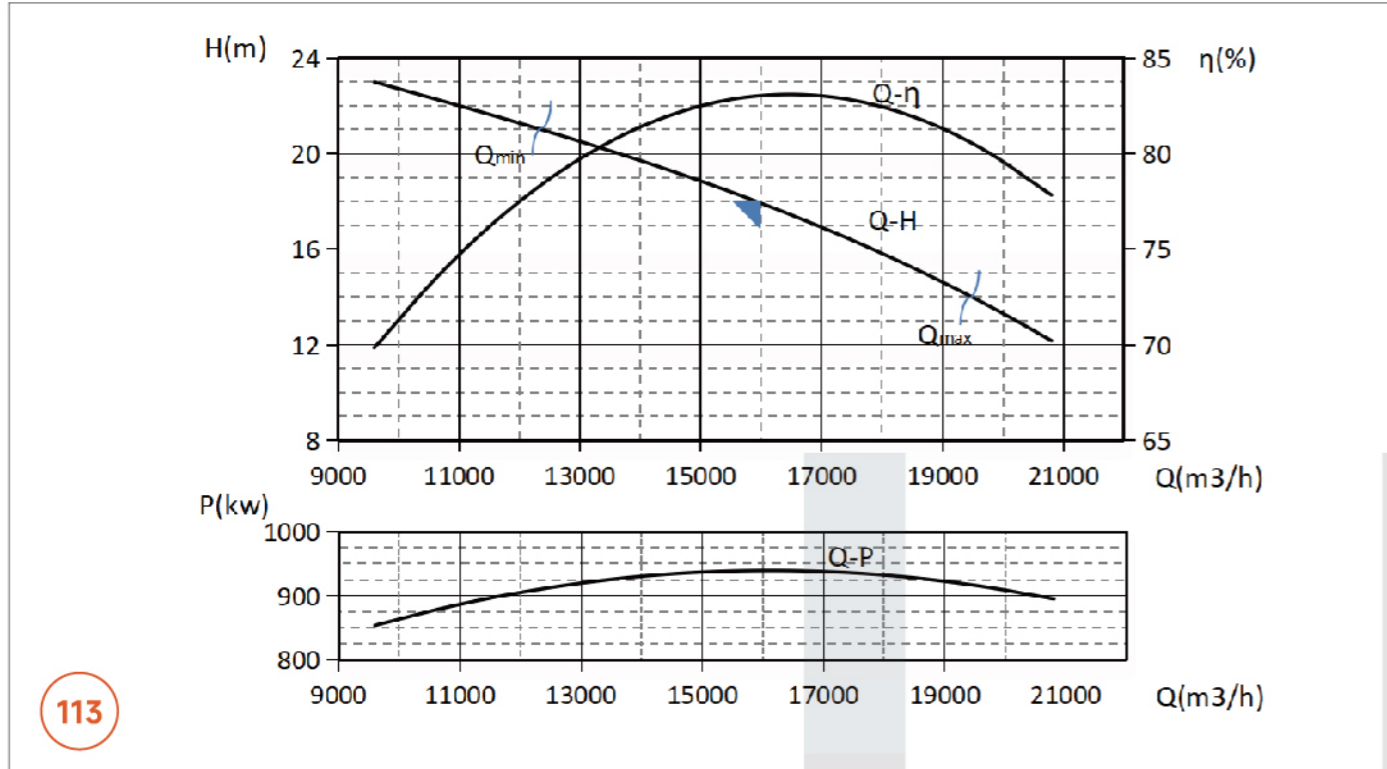

113

性能曲线图 / Performance curve

1400QHDX-22 型潜水混流泵性能曲线图 1400QHDX-22 type submersible Mixed-flow pump performance curve

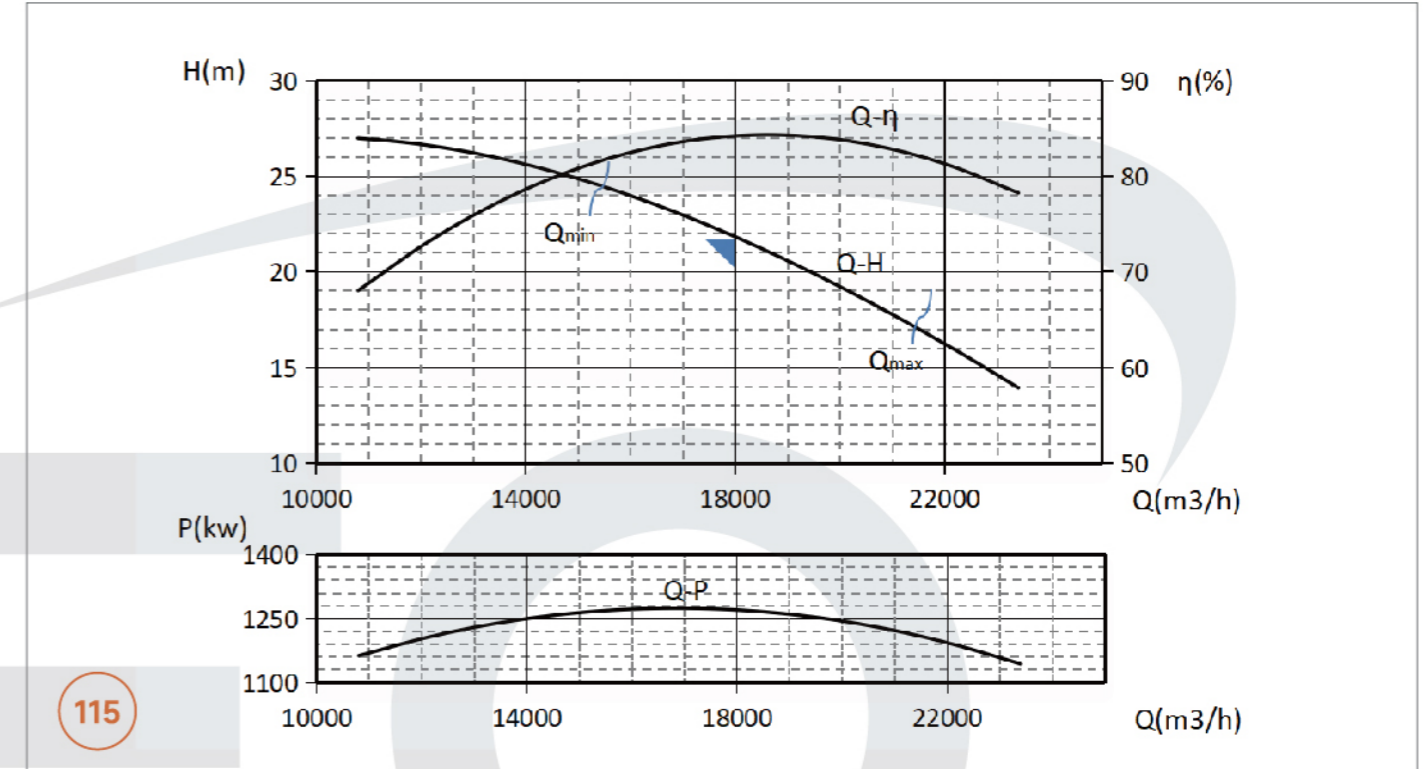

115

1400QHDX-20 型潜水混流泵性能曲线图 1400QHDX-20 type submersible Mixed-flow pump performance curve

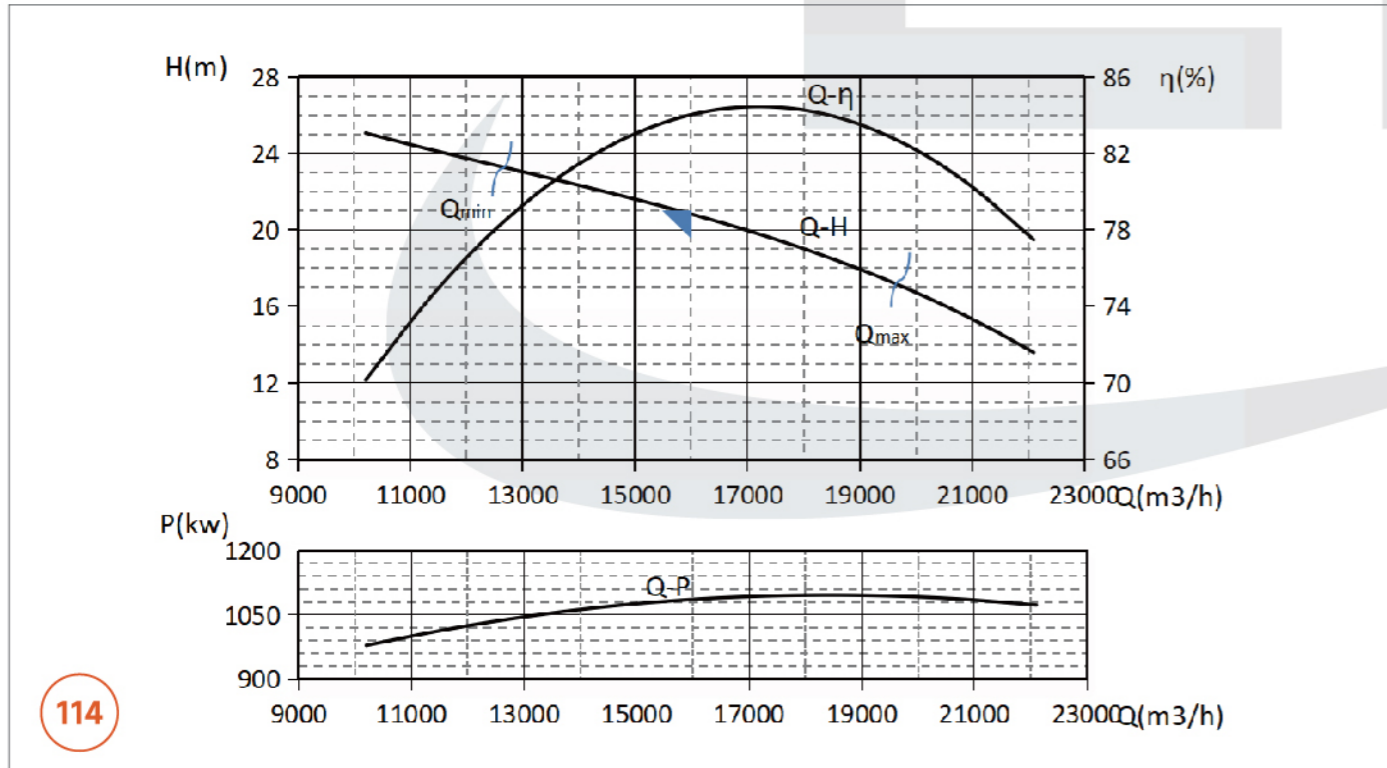

114

1600QHDX-9 型潜水混流泵性能曲线图 1600QHDX-9 type submersible Mixed-flow pump performance curve

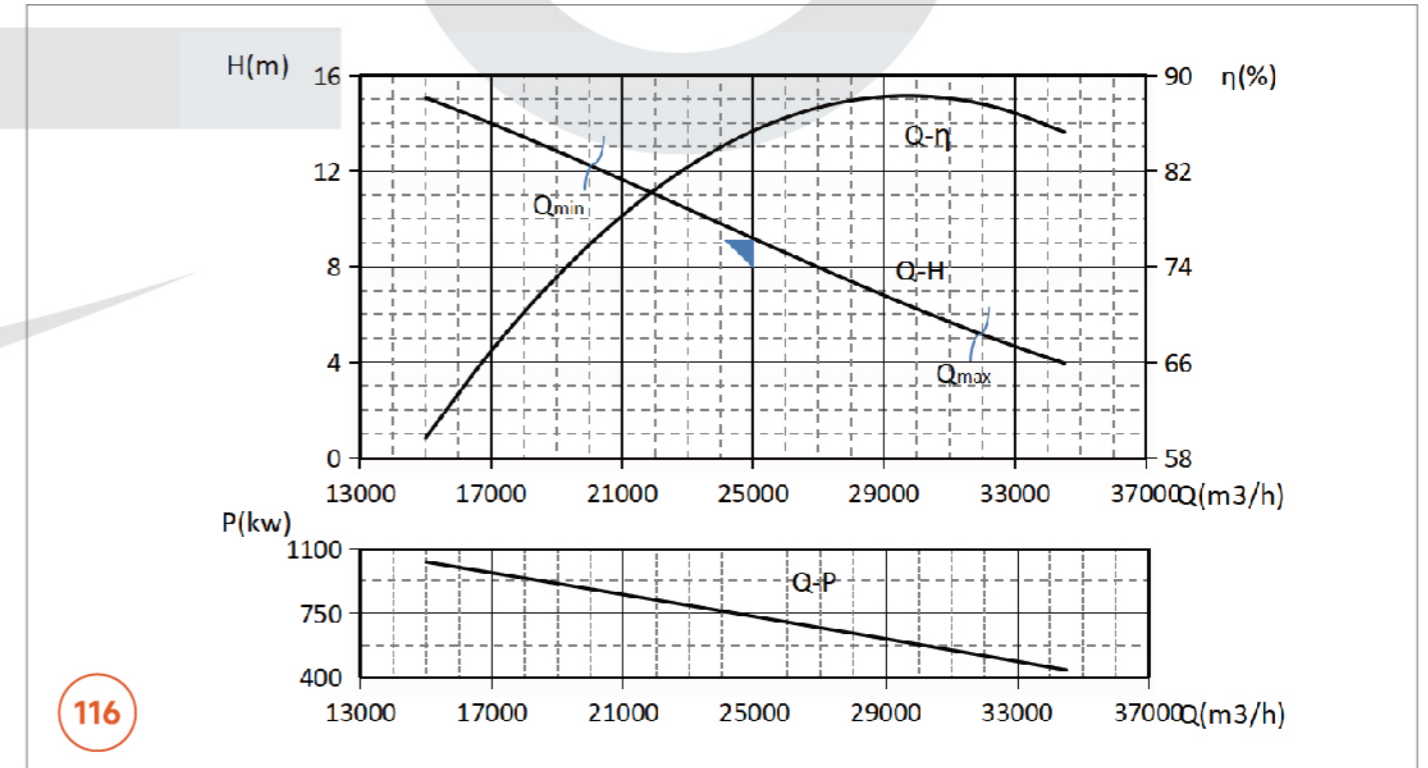

116

性能曲线图 / Performance curve

1600QHDX-10 型潜水混流泵性能曲线图 1600QHDX-10 type submersible Mixed-flow pump performance curve

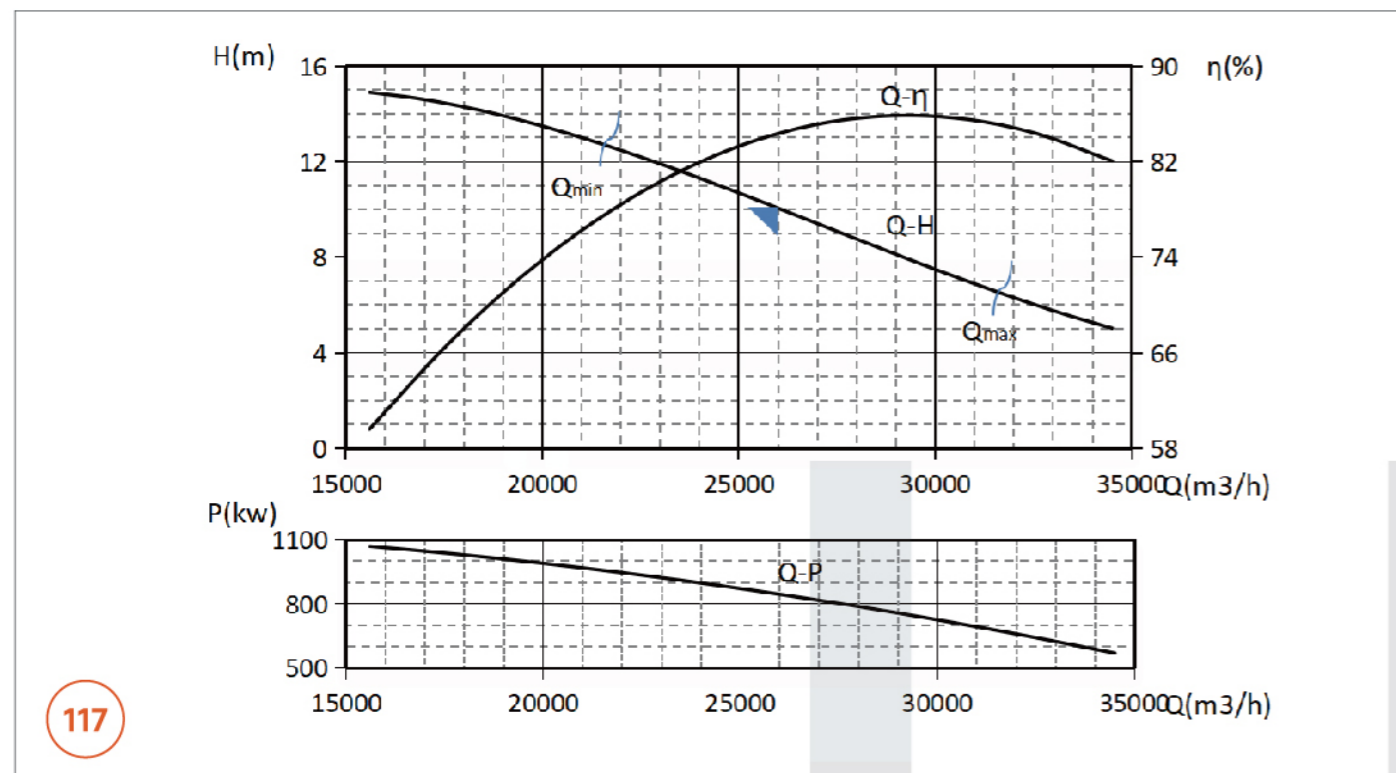

117

性能曲线图 / Performance curve

1600QHDX-12 型潜水混流泵性能曲线图 1600QHDX-12 type submersible Mixed-flow pump performance curve

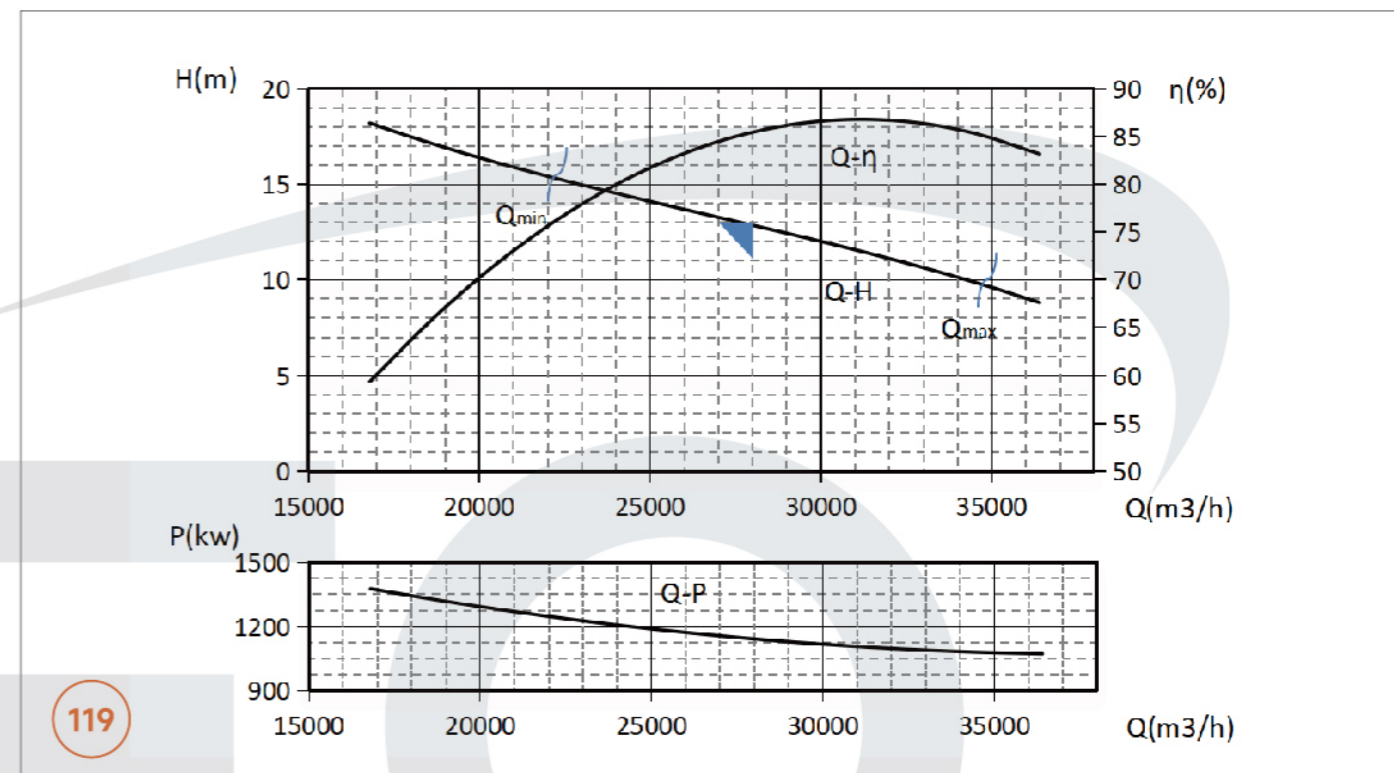

119

1600QHDX-11 型潜水混流泵性能曲线图 1600QHDX-11 type submersible Mixed-flow pump performance curve

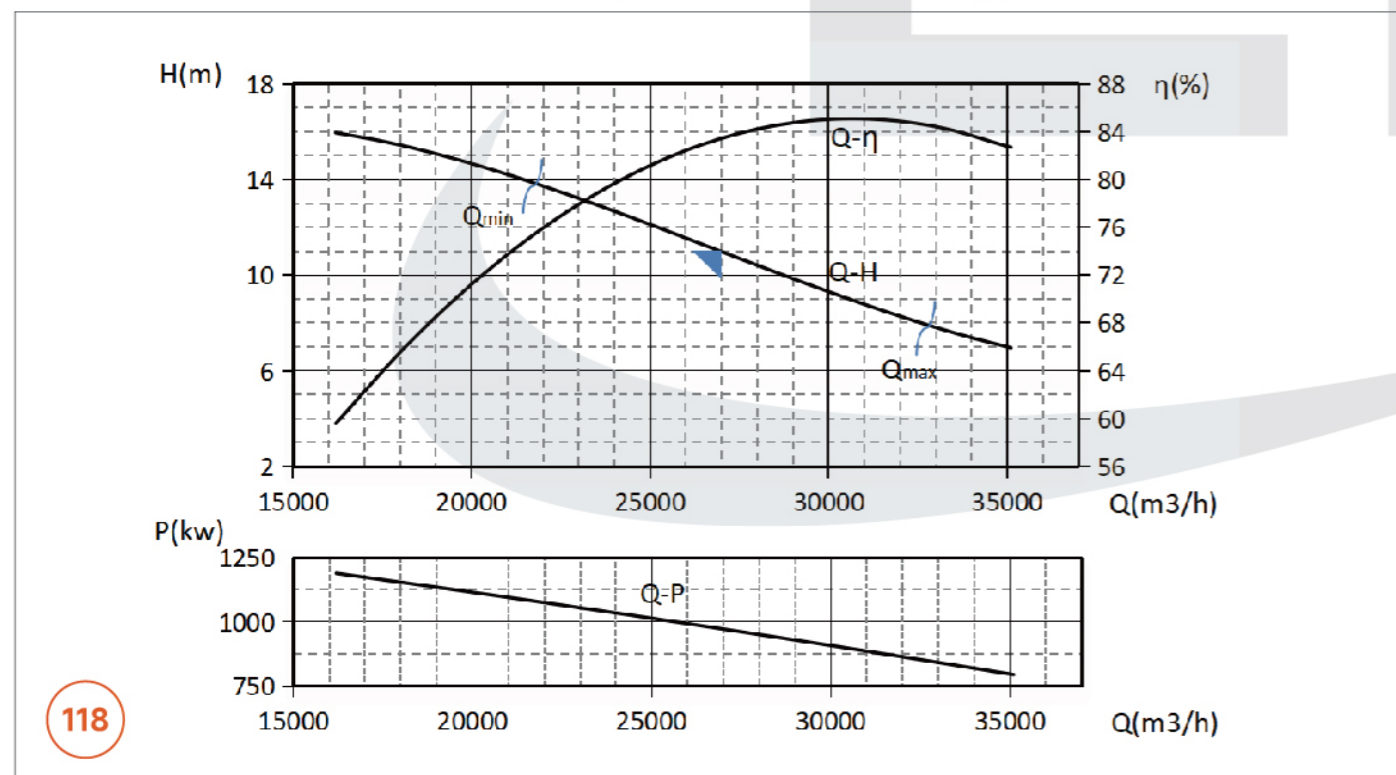

118

1600QHDX-13 型潜水混流泵性能曲线图 1600QHDX-13 type submersible Mixed-flow pump performance curve

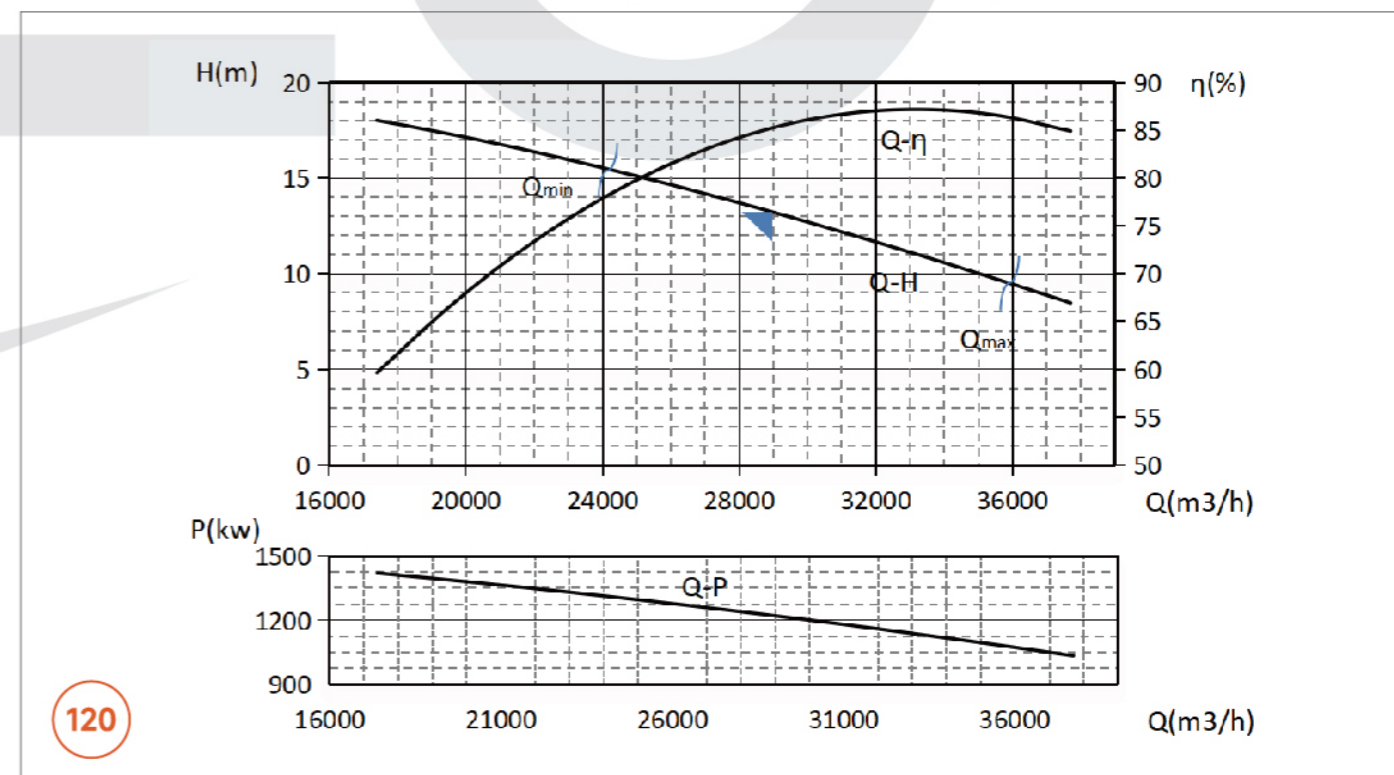

120

1600QHDX-14 型潜水混流泵性能曲线图 1600QHDX-14 type submersible Mixed-flow pump performance curve

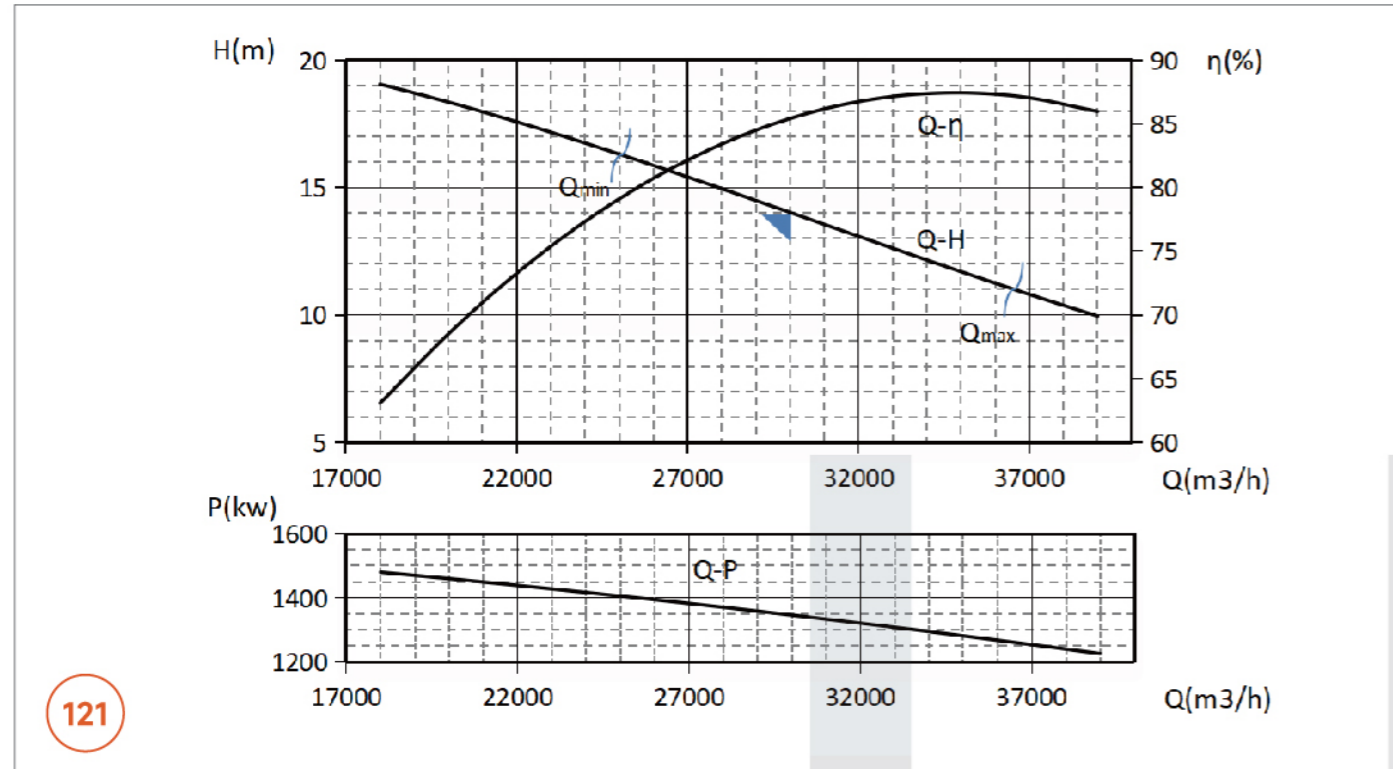

121

低压电机电气性能参数表 / Electric performance parameters of low voltage motor

序号 NO	电机型号 Motor Type	额定电压	转速	额定电流	额定功率	功率因数	电机效率	堵转转矩 / 额定转矩	最大转矩 / 额定转矩	堵转电流 / 额定电流	电机重量
		U(V)	n(r/min)	I(A)	N(kW)	Cos $\Phi$	Eff(%)	Tst/TN	TM/TN	Ist/IN	Weight of motor
1	YQH400-37KW-4P	380	1480	69.7	37	0.87	92.7	2.1	2.3	7.4	340
2	YQH400-45KW-4P	380	1480	84.4	45	0.87	93.1	2.1	2.3	7.4	360
3	YQH400-55KW-4P	380	1480	103.9	55	0.86	93.5	2.1	2.3	7.4	400
4	YQH400-65KW-4P	380	1480	122.4	65	0.86	93.8	2.1	2.3	7.4	450
5	YQH400-75KW-4P	380	1480	141.0	75	0.86	94.0	2.1	2.3	7.0	460
6	YQH400-90KW-4P	380	1480	168.8	90	0.86	94.2	2.1	2.3	7.0	520
7	YQH400-110KW-4P	380	1480	206.3	110	0.86	94.2	2.1	2.3	7.0	565
8	YQH520-110KW-4P	380	1480	203.3	110	0.87	94.5	2.1	2.3	7.0	850
9	YQH520-132KW-4P	380	1480	243.4	132	0.87	94.7	2.1	2.3	7.0	930
10	YQH520-160KW-4P	380	1480	297.9	160	0.86	94.9	2.1	2.3	7.0	1000
11	YQH520-185KW-4P	380	1480	344.0	185	0.86	95.0	2.1	2.3	7.0	1070
12	YQH520-200KW-4P	380	1480	371.6	200	0.86	95.1	2.1	2.3	7.0	1150
13	YQH520-220KW-4P	380	1480	413.5	220	0.85	95.1	2.1	2.3	7.0	1230
14	YQH590-250KW-4P	380	1450	464.4	250	0.86	95.1	2.1	2.3	7.0	1820
15	YQH400-65KW-6P	380	980	123.0	65	0.86	93.4	2.0	2.1	6.8	320
16	YQH400-75KW-6P	380	980	148.3	75	0.82	93.7	2.0	2.1	6.8	350
17	YQH400-90KW-6P	380	980	177.4	90	0.82	94.0	2.0	2.1	6.8	380
18	YQH400-110KW-6P	380	980	221.8	110	0.80	94.2	2.0	2.1	6.8	580
19	YQH520-110KW-6P	380	980	216.1	110	0.82	94.3	2.1	2.3	7.0	910
20	YQH520-132KW-6P	380	980	261.7	132	0.81	94.6	2.0	2.1	6.8	980
21	YQH520-160KW-6P	380	980	316.6	160	0.81	94.8	2.0	2.1	6.8	1080

低压电机电气性能参数表 / Electric performance parameters of low voltage motor

序号 NO	电机型号 Motor Type	额定电压	转速	额定电流	额定功率	功率因数	电机效率	堵转转矩 / 额定转矩	最大转矩 / 额定转矩	堵转电流 / 额定电流	电机重量
		U(V)	n(r/min)	I(A)	N(kW)	CosΦ	Eff(%)	Tst/TN	TM/TN	Ist/IN	Weight of motor
22	YQH520-185KW-6P	380	980	361.6	185	0.82	94.8	2.0	2.1	6.8	1200
23	YQH520-200KW-6P	380	980	390.9	200	0.82	94.8	2.0	2.1	6.8	1340
24	YQH520-220KW-6P	380	980	424.8	220	0.83	94.8	2.0	2.1	6.8	1480
25	YQH590-160KW-6P	380	980	330.2	160	0.78	94.4	2.0	2.1	6.8	1360
26	YQH590-185KW-6P	380	980	376.1	185	0.79	94.6	2.0	2.1	6.8	1420
27	YQH590-200KW-6P	380	980	400.7	200	0.80	94.8	2.0	2.1	6.8	1500
28	YQH590-220KW-6P	380	980	440.8	220	0.80	94.8	2.0	2.1	6.8	1610
29	YQH590-250KW-6P	380	980	493.6	250	0.81	95.0	2.0	2.1	6.8	1730
30	YQH590-280KW-6P	380	980	552.9	280	0.81	95.0	2.0	2.1	6.8	1860
31	YQH590-315KW-6P	380	980	614.4	315	0.82	95.0	2.0	2.1	6.8	2010
32	YQH670-355KW-6P	380	980	692.4	355	0.82	95.0	2.0	2.1	6.8	2600
33	YQH590-132KW-8P	380	740	296.3	132	0.72	94.0	1.8	2.3	6.5	1500
34	YQH590-160KW-8P	380	740	348.7	160	0.74	94.2	1.8	2.3	6.5	1590
35	YQH590-185KW-8P	380	740	391.4	185	0.76	94.5	1.8	2.3	6.5	1680
36	YQH590-200KW-8P	380	740	415.9	200	0.77	94.9	1.8	2.0	6.5	1800
37	YQH590-220KW-8P	380	740	451.6	220	0.78	94.9	1.8	2.0	6.5	1920
38	YQH590-250KW-8P	380	740	506.7	250	0.79	94.9	1.8	2.0	6.5	2060
39	YQH590-280KW-8P	380	740	560.4	280	0.80	94.9	1.8	2.0	6.6	2190
40	YQH670-315KW-8P	380	740	630.4	315	0.80	94.9	1.8	2.0	6.8	2800
41	YQH670-355KW-8P	380	980	710.5	355	0.80	94.9	1.8	2.0	6.8	2920

高压电机电气性能参数表 / Electric performance parameters of high voltage motor

序号 NO	电机型号 Motor Type	额定电压	转速	额定电流	额定功率	功率因数	电机效率	堵转转矩 / 额定转矩	最大转矩 / 额定转矩	堵转电流 / 额定电流	电机重量
		U(V)	n(r/min)	I(A)	N(kW)	CosΦ	Eff(%)	Tst/TN	TM/TN	Ist/IN	Weight of motor
1	YQHG850-800KW-4P	10000	1480	58.7	800	0.83	94.8	0.9	1.8	6.5	4800
2	YQHG990-900KW-4P	10000	1480	65.3	900	0.84	94.8	0.9	1.8	6.5	6200
3	YQHG990-1000KW-4P	10000	1480	72.4	1000	0.84	95.0	0.9	1.8	6.5	6400
4	YQHG990-1120KW-4P	10000	1480	79.8	1120	0.85	95.3	0.9	1.8	6.5	6600
5	YQHG990-1250KW-4P	10000	1480	89.0	1250	0.85	95.4	0.9	1.8	6.5	6800
6	YQHG990-1350KW-4P	10000	1480	94.7	1350	0.86	95.7	0.9	1.8	6.5	6900
7	YQHG990-1400KW-4P	10000	1480	98.2	1400	0.86	95.7	0.9	1.8	6.5	7000
8	YQHG990-1600KW-4P	10000	1480	112.1	1600	0.86	95.8	0.9	1.8	6.5	7300
9	YQHG670-355KW-6P	10000	980	28.4	355	0.78	92.4	0.8	1.8	6.0	3150
10	YQHG740-400KW-6P	10000	980	32.0	400	0.78	92.6	0.8	1.8	6.0	3370
11	YQHG740-450KW-6P	10000	980	35.9	450	0.78	92.8	0.8	1.8	6.0	3470
12	YQHG740-500KW-6P	10000	980	39.7	500	0.78	93.2	0.8	1.8	6.0	3570
13	YQHG740-560KW-6P	10000	980	43.8	560	0.79	93.5	0.8	1.8	6.0	3670
14	YQHG850-630KW-6P	10000	980	49.1	630	0.79	93.8	0.8	1.8	6.0	4500
15	YQHG850-710KW-6P	10000	980	55.2	710	0.79	94.0	0.8	1.8	6.0	4600
16	YQHG850-800KW-6P	10000	980	62.1	800	0.79	94.2	0.8	1.8	6.0	4700
17	YQHG990-900KW-6P	10000	980	68.8	900	0.80	94.4	0.8	1.8	6.0	8500
18	YQHG990-1000KW-6P	10000	980	74.4	1000	0.82	94.6	0.8	1.8	6.0	8630
19	YQHG990-1120KW-6P	10000	980	83.2	1120	0.82	94.8	0.8	1.8	6.0	8780
20	YQHG990-1250KW-6P	10000	980	91.7	1250	0.83	94.8	0.8	1.8	6.0	8930
21	YQHG990-1400KW-6P	10000	980	101.4	1400	0.84	94.9	0.8	1.8	6.0	9100
22	YQHG1080-1600KW-6P	10000	980	115.8	1600	0.84	95.0	0.8	1.8	6.0	10800
23	YQHG670-315KW-8P	10000	740	27.2	315	0.72	92.8	0.8	1.8	6.0	3610
24	YQHG740-355KW-8P	10000	740	30.7	355	0.72	92.8	0.8	1.8	5.5	3950
25	YQHG740-400KW-8P	10000	740	33.0	400	0.75	93.2	0.8	1.8	5.5	4050
26	YQHG740-450KW-8P	10000	740	36.1	450	0.77	93.4	0.8	1.8	5.5	4150
27	YQHG740-500KW-8P	10000	740	40.0	500	0.77	93.8	0.8	1.8	5.5	4450
28	YQHG850-530KW-8P	10000	740	41.3	530	0.79	93.8	0.8	1.8	5.5	4550
29	YQHG850-560KW-8P	10000	740	43.6	560	0.79	93.9	0.8	1.8	5.5	4700
30	YQHG850-630KW-8P	10000	740	48.4	630	0.80	94.0	0.8	1.8	5.5	4950
31	YQHG990-710KW-8P	10000	740	52.8	710	0.82	94.6	0.8	1.8	5.5	6200

高压电机电气性能参数表 / Electric performance parameters of high voltage motor

序号 NO	电机型号 Motor Type	额定电压	转速	额定电流	额定功率	功率因数	电机效率	堵转转矩 / 额定转矩	最大转矩 / 额定转矩	堵转电流 / 额定电流	电机重量
		U(V)	n(r/min)	I(A)	N(kW)	CosΦ	Eff(%)	Tst/TN	TM/TN	Ist/IN	Weight of motor
32	YQHG990-760KW-8P	10000	740	56.5	760	0.82	94.7	0.8	1.8	5.5	6450
33	YQHG990-800KW-8P	10000	740	59.5	800	0.82	94.7	0.8	1.8	5.5	6700
34	YQHG1080-1000KW-8P	10000	740	72.6	1000	0.84	94.7	0.8	1.8	5.5	8700
35	YQHG1080-1120KW-8P	10000	740	80.2	1120	0.85	94.8	0.8	1.8	5.5	9000
36	YQHG1180-1350KW-8P	10000	740	95.6	1350	0.86	94.8	0.8	1.8	5.5	11200
37	YQHG740-280KW-10P	10000	590	24.3	280	0.72	92.3	0.8	1.8	5.5	4260
38	YQHG740-315KW-10P	10000	590	26.9	315	0.73	92.5	0.8	1.8	5.5	4350
39	YQHG740-355KW-10P	10000	590	29.9	355	0.74	92.7	0.8	1.8	5.5	4550
40	YQHG740-400KW-10P	10000	590	33.1	400	0.75	92.9	0.8	1.8	5.5	4550
41	YQHG850-450KW-10P	10000	590	36.7	450	0.76	93.1	0.8	1.8	5.5	5400
42	YQHG850-500KW-10P	10000	590	40.7	500	0.76	93.3	0.8	1.8	5.5	5580
43	YQHG850-560KW-10P	10000	590	44.3	560	0.78	93.5	0.8	1.8	5.5	5760
44	YQHG990-630KW-10P	10000	590	49.8	630	0.78	93.7	0.8	1.8	5.5	7800
45	YQHG990-710KW-10P	10000	590	56.0	710	0.78	93.9	0.8	1.8	5.5	8100
46	YQHG990-800KW-10P	10000	590	63.1	800	0.78	93.9	0.8	1.8	5.5	8400
47	YQHG1080-1000KW-10P	10000	590	77.7	1000	0.79	94.0	0.8	1.8	5.5	9700
48	YQHG1080-1120KW-10P	10000	590	87.1	1120	0.79	94.0	0.8	1.8	5.5	10200
49	YQHG1080-1250KW-10P	10000	590	97.2	1250	0.79	94.0	0.8	1.8	5.5	10800
50	YQHG850-400KW-12P	10000	490	34.1	400	0.73	92.9	0.7	1.8	4.8	5050
51	YQHG850-450KW-12P	10000	490	38.3	450	0.73	92.9	0.7	1.8	4.8	5200
52	YQHG900-500KW-12P	10000	490	41.9	500	0.74	93.2	0.7	1.8	4.8	6300
53	YQHG900-560KW-12P	10000	490	46.7	560	0.74	93.5	0.7	1.8	4.8	6500
54	YQHG990-630KW-12P	10000	490	52.5	630	0.74	93.7	0.7	1.8	4.8	8200
55	YQHG990-710KW-12P	10000	490	59.1	710	0.74	93.8	0.7	1.8	4.8	8500
56	YQHG990-800KW-12P	10000	490	65.7	800	0.75	93.8	0.7	1.8	4.8	8900
57	YQHG990-450KW-14P	10000	490	40.2	450	0.70	92.3	0.7	1.8	4.8	9800
58	YQHG990-530KW-14P	10000	490	47.3	530	0.70	92.5	0.7	1.8	4.8	10000
59	YQHG990-630KW-14P	10000	425	54.5	630	0.72	92.7	0.6	1.8	5.0	10350
60	YQHG990-710KW-14P	10000	425	61.4	710	0.72	92.7	0.6	1.8	5.0	10750
61	YQHG990-800KW-14P	10000	425	68.1	800	0.73	92.9	0.6	1.8	5.0	11300

水泵和电机型号对照表一 / Comparison Table of Low pressure Water Pump and Motor Models One

序号 NO	水泵型号 pump type	电机型号 motor type
1	350QHD-8	YQH400-37KW-4P
2	350QHD-9	YQH400-45KW-4P
3	350QHD-11	YQH400-65KW-4P
4	350QHD-13	YQH400-75KW-4P
5	350QHD-12	YQH400-37KW-4P
6	350QHD-14	YQH400-45KW-4P
7	350QHD-16	YQH400-55KW-4P
8	350QHD-17	YQH400-65KW-4P
9	350QHD-18	YQH400-75KW-4P
10	350QHD-19	YQH400-90KW-4P
11	350QHD-22	YQH400-55KW-4P
12	350QHD-24	YQH400-65KW-4P
13	350QHD-26	YQH400-75KW-4P
14	350QHD-28	YQH400-90KW-4P
15	350QHD-30	YQH400-110KW-4P
16	350QHD-32	YQH520-132KW-4P
17	500QHD-8	YQH400-90KW-6P
18	500QHD-7.5	YQH400-65KW-6P
19	500QHD-9	YQH400-75KW-6P
20	500QHD-10	YQH400-90KW-6P
21	500QHD-11	YQH400-110KW-6P
22	500QHD-12	YQH520-132KW-6P
23	500QHD-14	YQH520-132KW-6P
24	500QHD-16	YQH520-160KW-6P
25	500QHD-18	YQH520-200KW-6P
26	500QHD-20	YQH520-220KW-6P
27	500QHD-21	YQH520-160KW-6P
28	500QHD-20.5	YQH520-110KW-6P

水泵和电机型号对照表一 / Comparison Table of Low pressure Water Pump and Motor Models One

序号 NO	水泵型号 pump type	电机型号 motor type
29	500QHD-22	YQH520-132KW-6P
30	500QHD-25	YQH520-160KW-6P
31	500QHD-30	YQH520-160KW-4P
32	500QHD-34	YQH520-200KW-4P
33	500QHD-38	YQH520-220KW-4P
34	500QHD-42	YQH590-250KW-4P
35	600QHD-10	YQH590-132KW-8P
36	600QHD-12	YQH590-160KW-8P
37	600QHD-14	YQH590-185KW-8P
38	600QHD-16	YQH590-220KW-8P
39	600QHD-18	YQH590-250KW-8P
40	600QHD-15	YQH590-185KW-8P
41	600QHD-17	YQH590-220KW-8P
42	600QHD-20	YQH590-280KW-8P
43	600QHD-23	YQH590-280KW-6P
44	600QHD-25	YQH590-315KW-6P
45	600QHD-26	YQH520-200KW-6P
46	600QHD-28	YQH590-220KW-6P
47	600QHD-30	YQH590-250KW-6P
48	600QHD-31	YQH590-280KW-6P
49	600QHD-32	YQH590-315KW-6P
50	600QHD-35	YQH590-355KW-6P
51	700QHD-8	YQH590-132KW-8P
52	700QHD-9	YQH590-160KW-8P
53	700QHD-10	YQH590-200KW-8P
54	700QHD-11	YQH590-250KW-8P
55	700QHD-18	YQH590-315KW-8P

水泵和电机型号对照表二 / Comparison Table of Low pressure Water Pump and Motor Models Two

序号 NO	水泵型号 pump type	电机型号 motor type
1	700QHD-20	YQH740-400KW-8P
2	700QHD-22	YQH740-450KW-8P
3	700QHD-24	YQH850-530KW-8P
4	700QHD-27	YQH740-355KW-8P
5	700QHD-30	YQH740-450KW-8P
6	700QHD-32	YQH670-355KW-6P
7	700QHD-35	YQH740-400KW-6P
8	700QHD-37	YQH740-450KW-6P
9	700QHD-40	YQH740-500KW-6P
10	700QHD-42	YQH850-630KW-6P
11	700QHD-45	YQH850-710KW-6P
12	700QHD-50	YQH850-800KW-6P
13	800QHD-12	YQH670-315KW-8P
14	800QHD-14	YQH740-355KW-8P
15	800QHD-16	YQH740-450KW-8P
16	800QHD-18	YQH740-450KW-8P
17	800QHD-25	YQH850-630KW-8P
18	800QHD-28	YQH990-710KW-8P
19	800QHD-31	YQH990-800KW-8P
20	800QHD-33	YQH850-530KW-8P
21	800QHD-35	YQH850-630KW-8P
22	800QHD-38	YQH990-760KW-8P
23	900QHD-9	YQH740-280KW-10P
24	900QHD-10	YQH740-315KW-10P
25	900QHD-11	YQH740-355KW-10P
26	900QHD-12	YQH740-400KW-10P
27	900QHD-13	YQH850-450KW-10P
28	900QHD-14	YQH850-500KW-10P
29	900QHD-15	YQH850-560KW-10P
30	900QHDX-38	YQH990-1000KW-4P
31	900QHDX-43	YQH990-1120KW-4P
32	900QHDX-48	YQH990-1350KW-4P
33	1000QHD-8	YQH850-400KW-12P

水泵和电机型号对照二 / Comparison Table of Low pressure Water Pump and Motor Models Two

序号 NO	水泵型号 pump type	电机型号 motor type
34	1000QHD-9	YQH850-450KW-12P
35	1000QHD-10	YQH900-500KW-12P
36	1000QHD-14	YQH990-630KW-12P
37	1000QHD-15	YQH990-710KW-12P
38	1000QHD-20	YQH990-710KW-10P
39	1000QHD-22	YQH990-800KW-10P
40	1000QHDX-26	YQH850-1000KW-4P
41	1000QHDX-29	YQH850-1120KW-4P
42	1000QHDX-35	YQH850-1120KW-4P
43	1000QHDX-39	YQH850-1250KW-4P
44	1200QHD-8.5	YQH990-450KW-14P
45	1200QHD-10	YQH990-530KW-14P
46	1200QHD-11	YQH990-630KW-14P
47	1200QHD-12	YQH990-710KW-14P
48	1200QHDX-19	YQH850-900KW-4P
49	1200QHDX-21	YQH990-1000KW-4P
50	1200QHDX-22	YQH990-1120KW-4P
51	1200QHDX-28	YQH990-1250KW-4P
52	1200QHDX-30	YQH990-1400KW-4P
53	1400QHDX-12.5	YQH850-800KW-4P
54	1400QHDX-13	YQH990-900KW-4P
55	1400QHDX-14	YQH990-1000KW-4P
56	1400QHDX-15	YQH990-1120KW-4P
57	1400QHDX-16	YQH990-1250KW-4P
58	1400QHDX-18	YQH990-1000KW-4P
59	1400QHDX-20	YQH990-1250KW-4P
60	1400QHDX-22	YQH990-1400KW-8P
61	1600QHDX-9	YQH990-900KW-4P
62	1600QHDX-10	YQH990-1000KW-4P
63	1600QHDX-11	YQH990-1120KW-4P
64	1600QHDX-12	YQH990-1250KW-4P
65	1600QHDX-13	YQH990-1400KW-4P
66	1600QHDX-14	YQH990-1600KW-4P

350QHD 型潜水混流泵外形安装图 (DN800)  
Erection view for 350QHD submersible Mixed-flow pump (DN800)

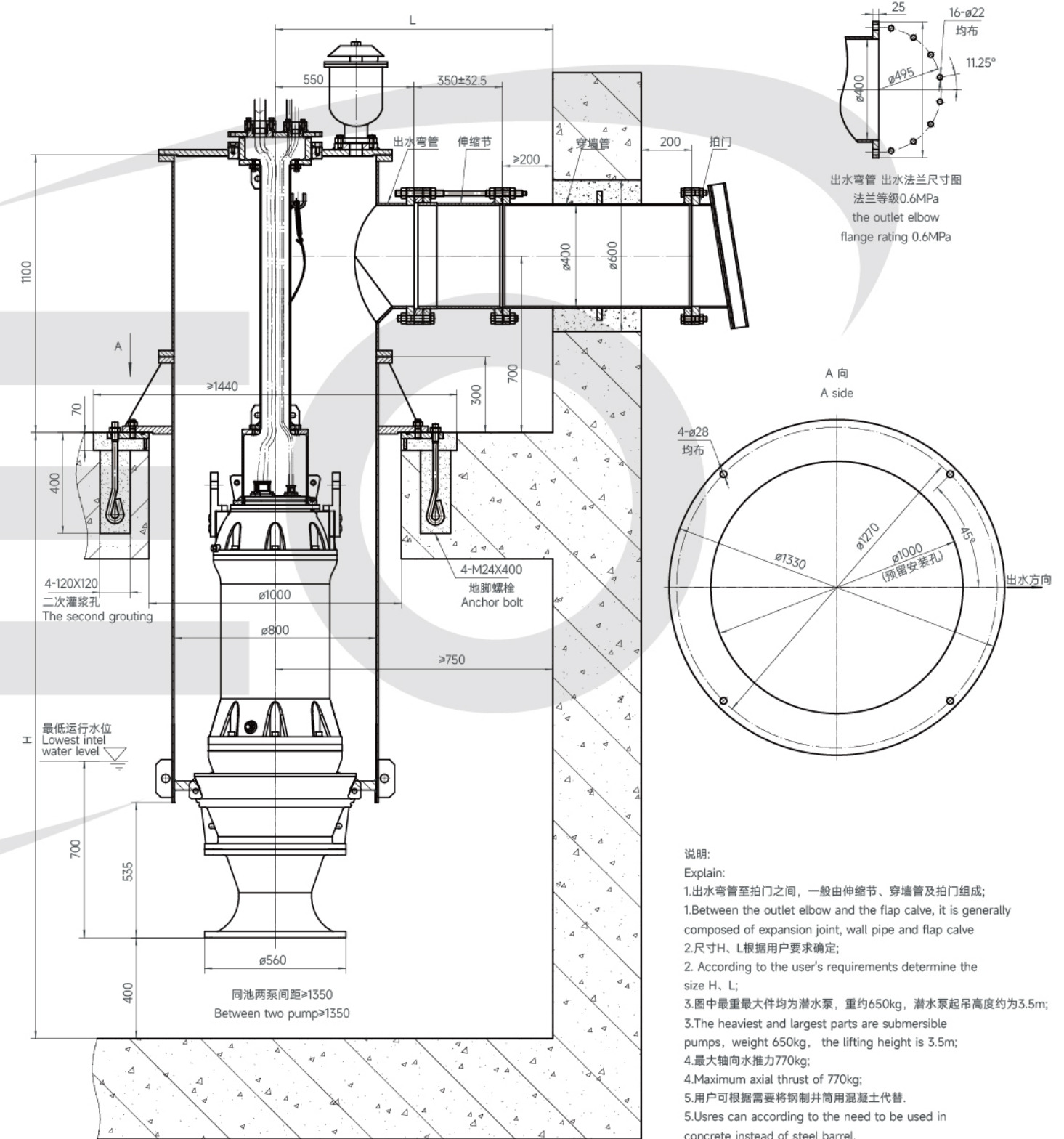

**500QHD-8、7.5、9、10、11 型潜水混流泵外形安装图 (DN850)**

**Erection view for 500QHD-8、7.5、9、10、11 submersible Mixed-flow pump (DN850)**

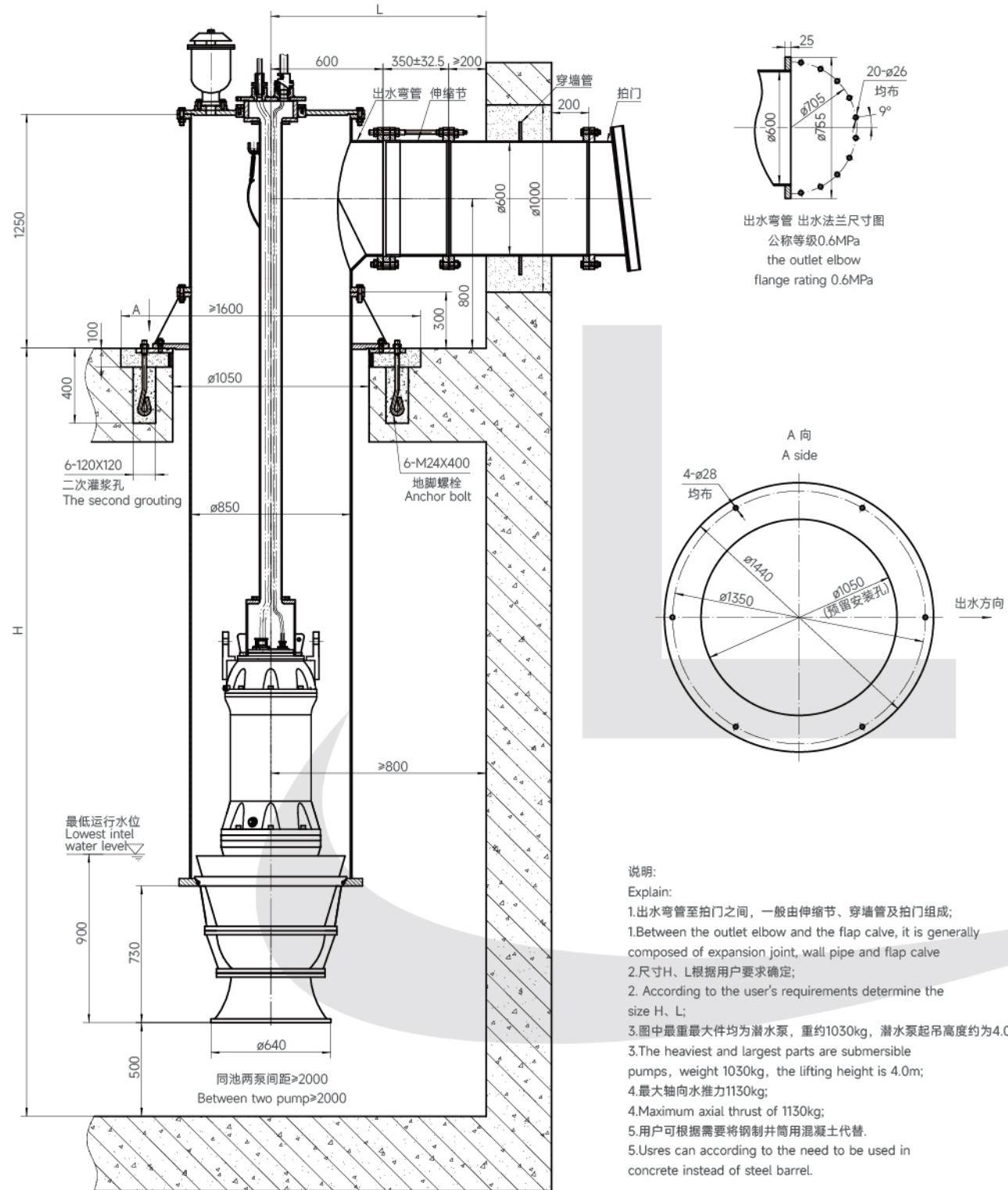

**500QHD-12、14、16、18、20、21、20.5、22、25、30、34、38、42 型潜水混流泵外形安装图 (DN1000)**

**Erection view for 500QHD-12、14、16、18、20、21、20.5、22、25、30、34、38、42 submersible Mixed-flow pump (DN1000)**

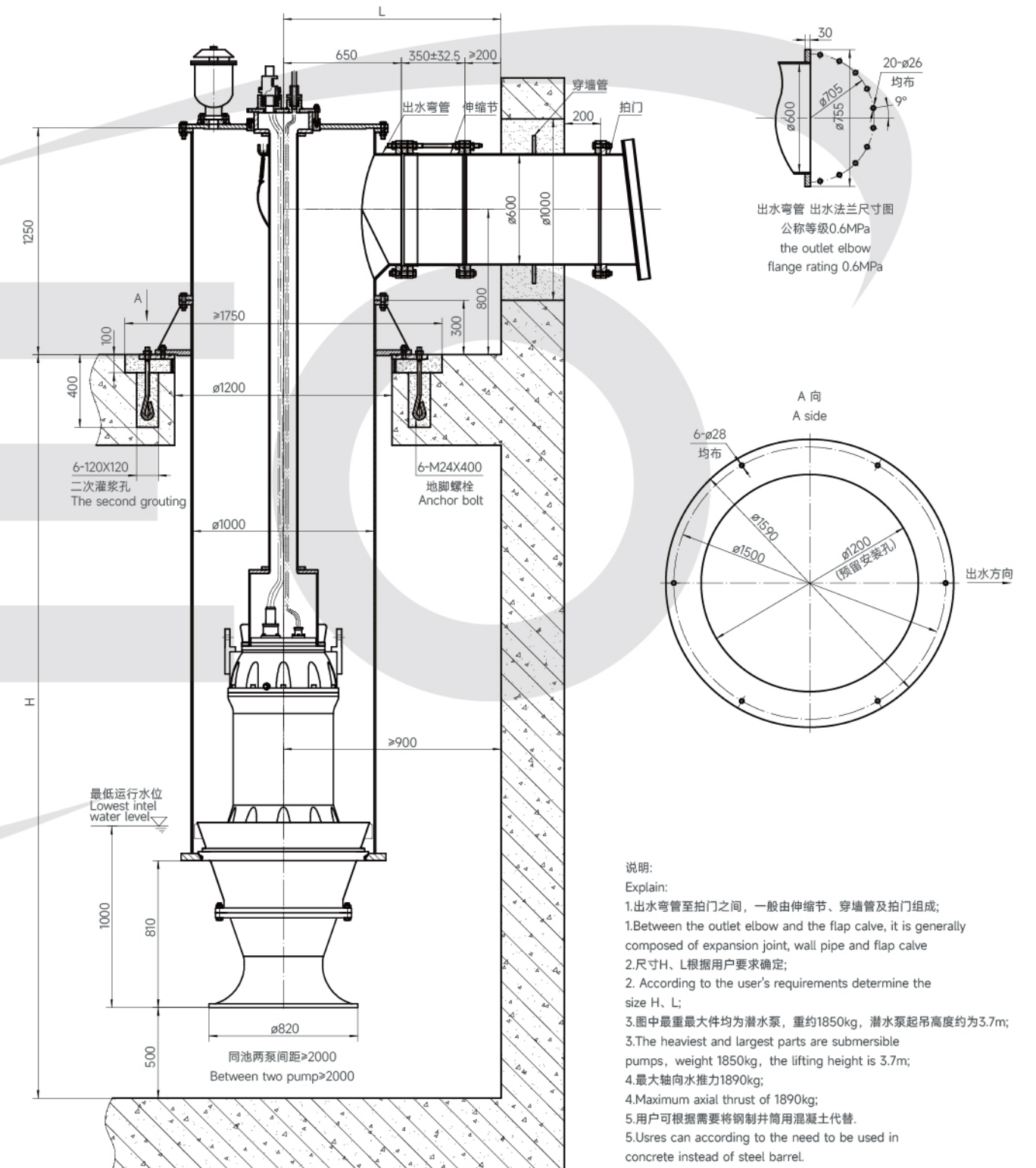

**600QHD-10、12、14、15、16、17、18、20、23、25 型潜水混流泵外形安装图 (DN1000)**  
Erection view for 600QHD-10、12、14、15、16、17、18、20、23、25 submersible Mixed-flow pump (DN1000)

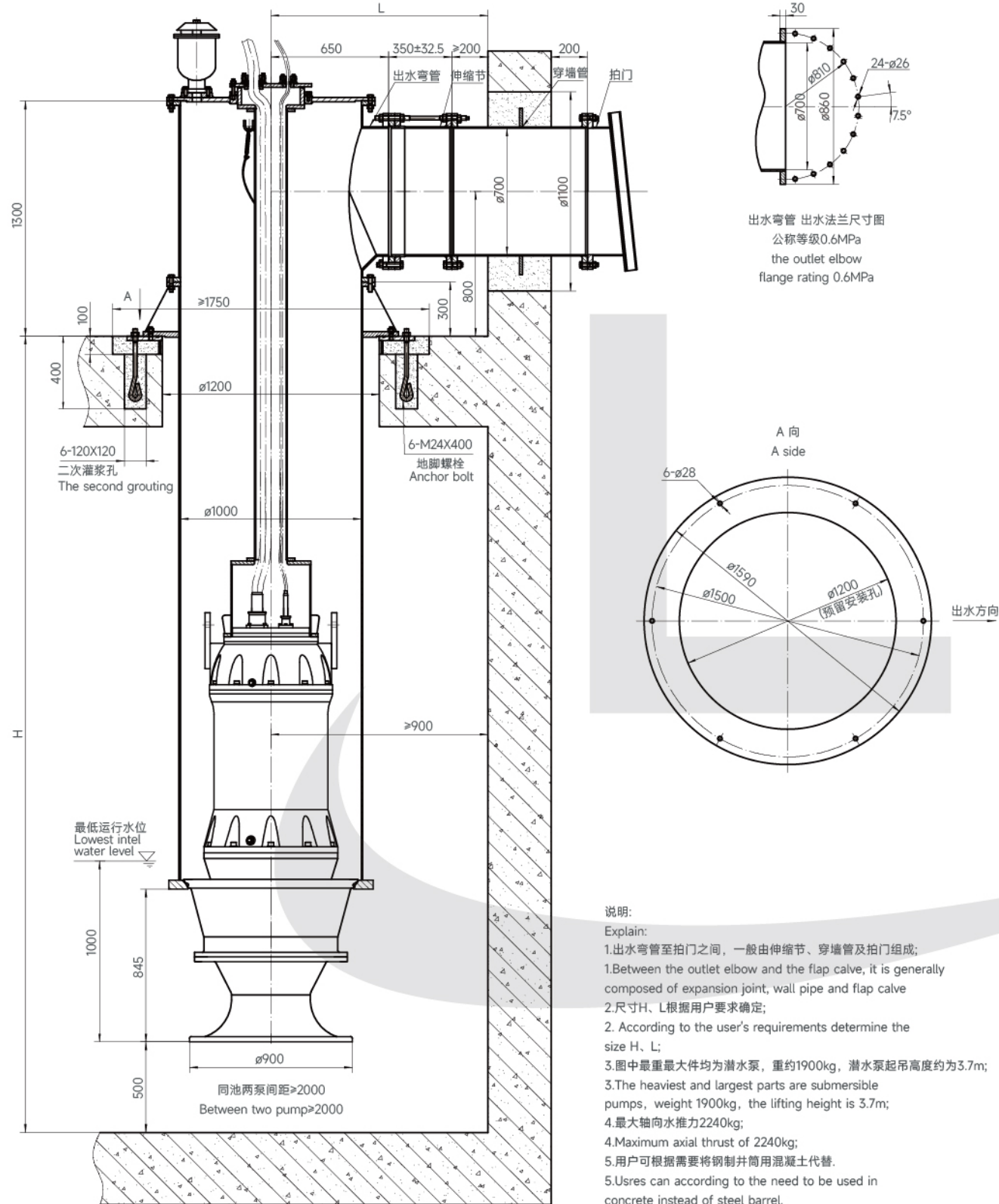

**600QHD-26、28、30、31、32、35 型潜水混流泵外形安装图 (DN1100)**  
Erection view for 600QHD-26、28、30、31、32、35 submersible Mixed-flow pump (DN1100)

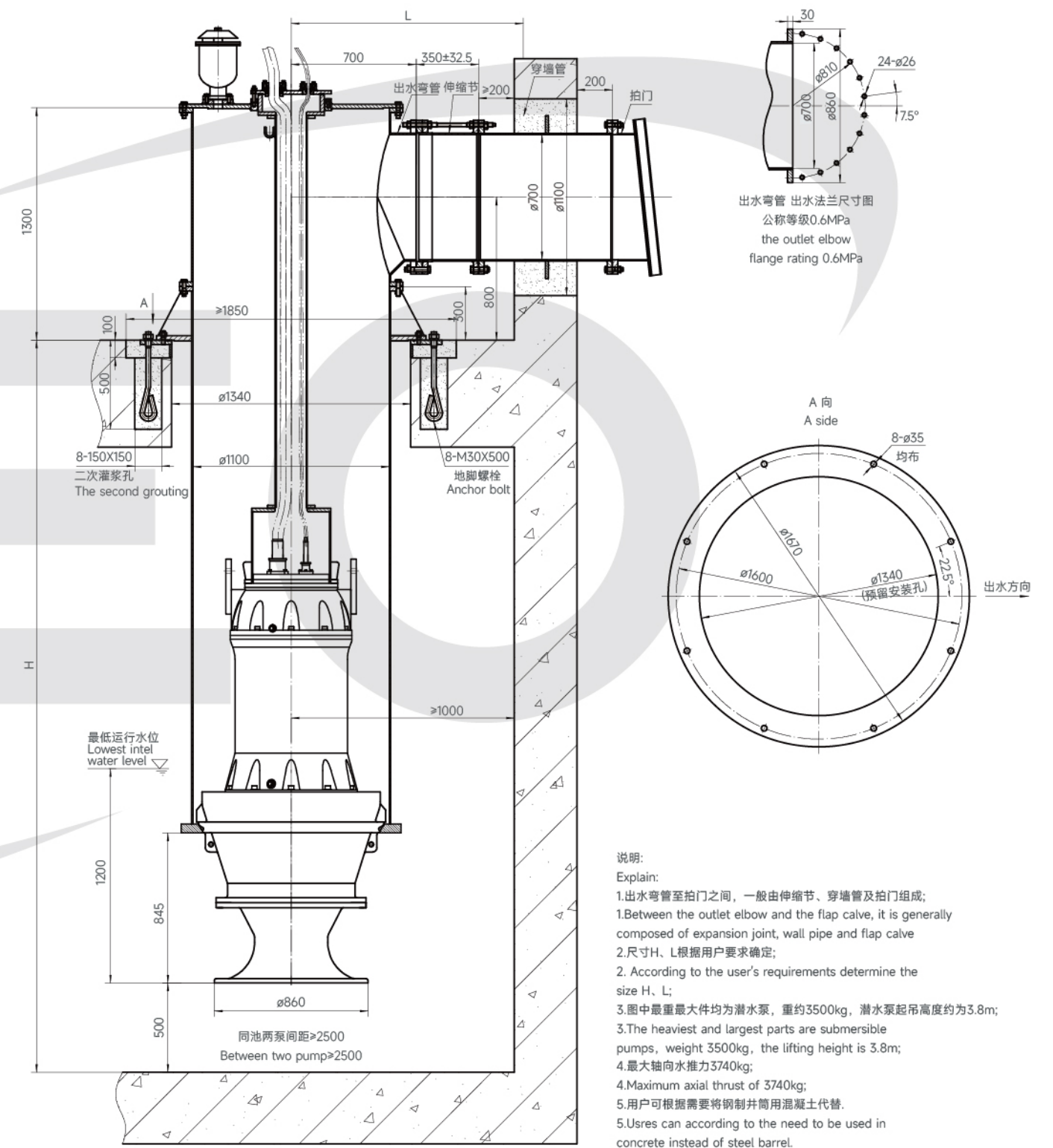

**700QHD-8、9、10、11 型潜水混流泵外形安装图 (DN1100)**

**Erection view for 700QHD-8、9、10、11 submersible Mixed-flow pump (DN1100)**

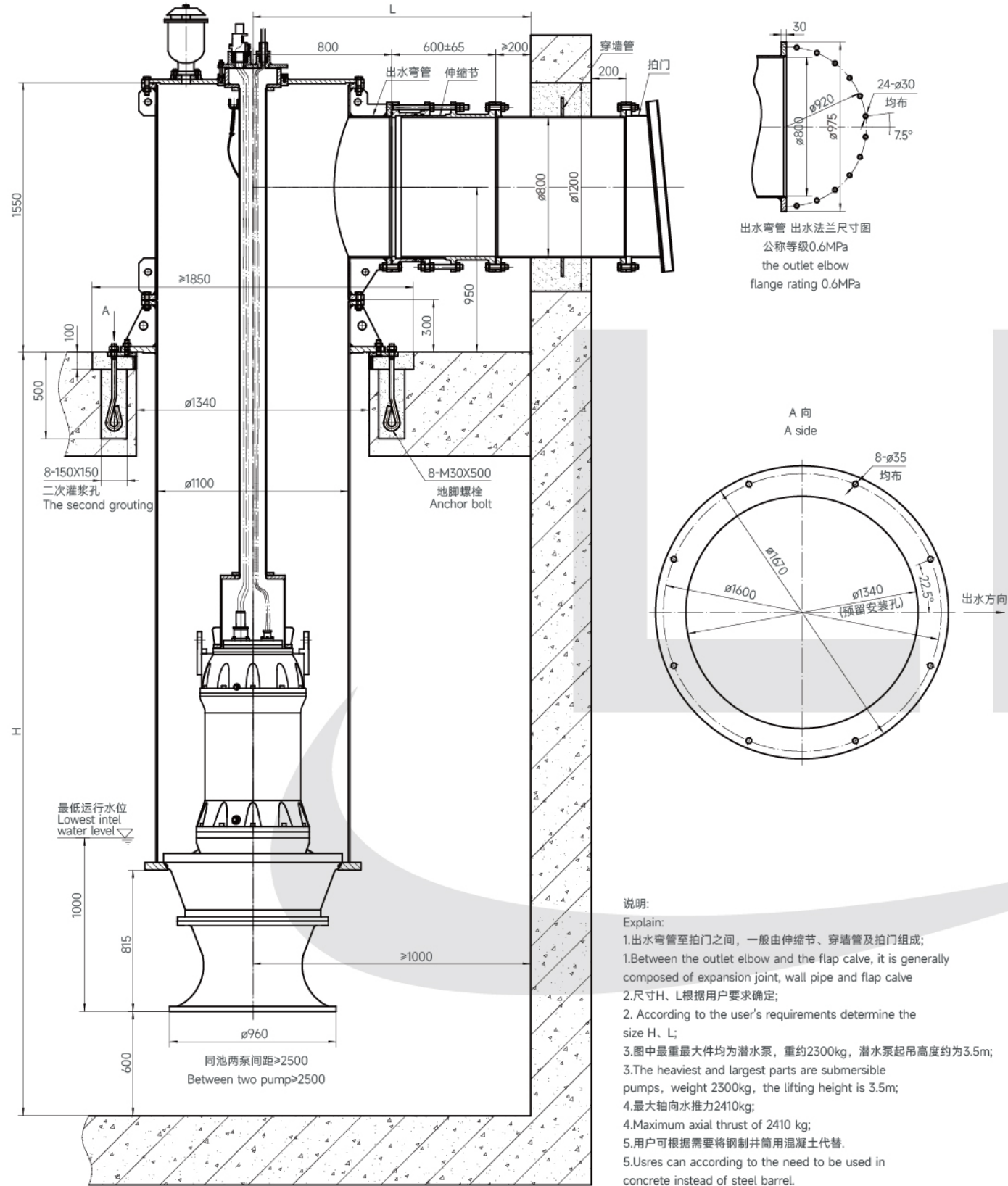

**700QHD-18、20、22、24、27、30、32、35、37、40 型潜水混流泵外形安装图 (DN1350)**

**Erection view for 700QHD-18、20、22、24、27、30、32、35、37、40 submersible Mixed-flow pump (DN1350)**

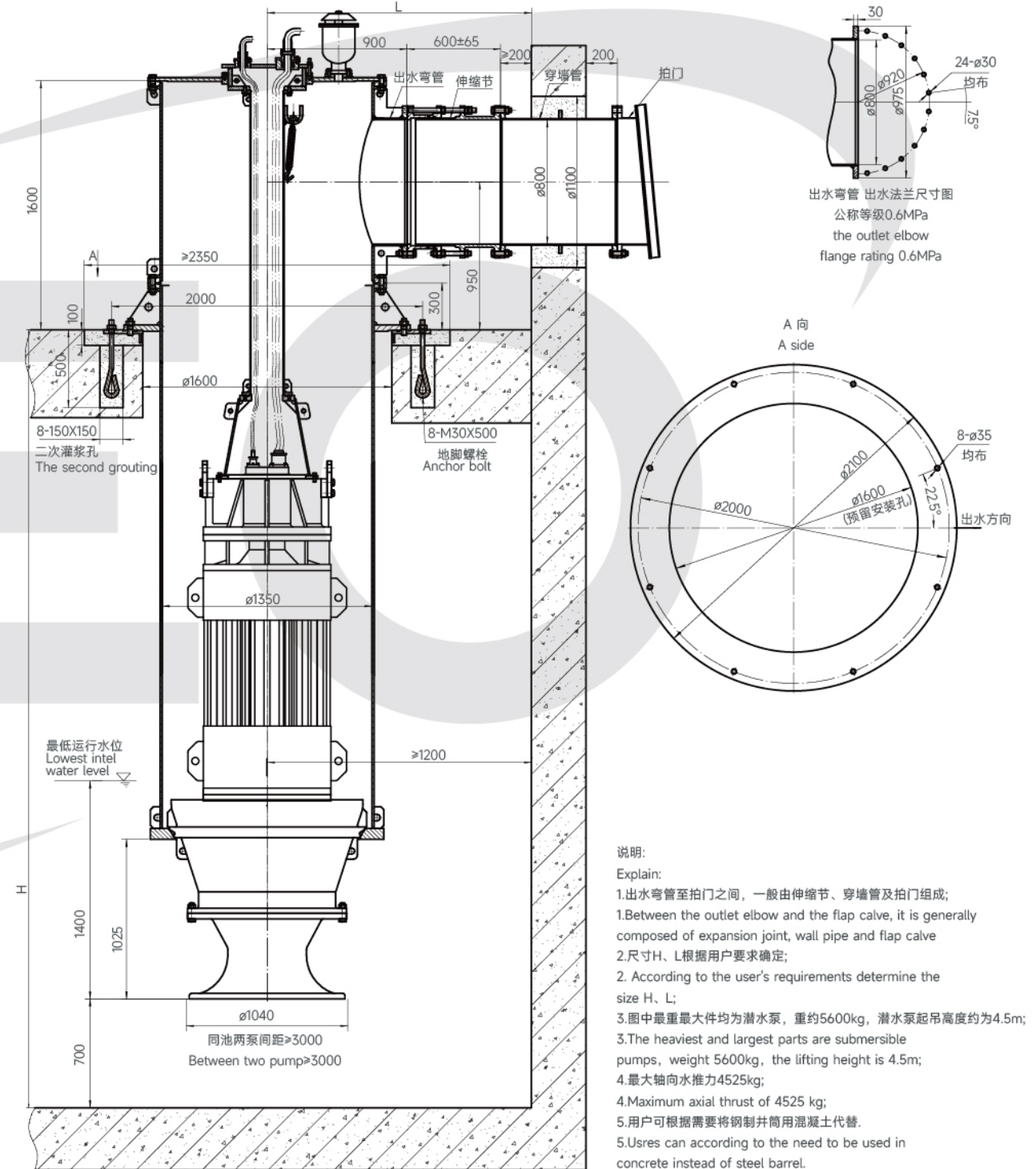

**700QHD-42、45、50 型潜水混流泵外形图 (DN1500)**

**Erection view for 700QHD-42、45、50 submersible Mixed-flow pump (DN1500)**

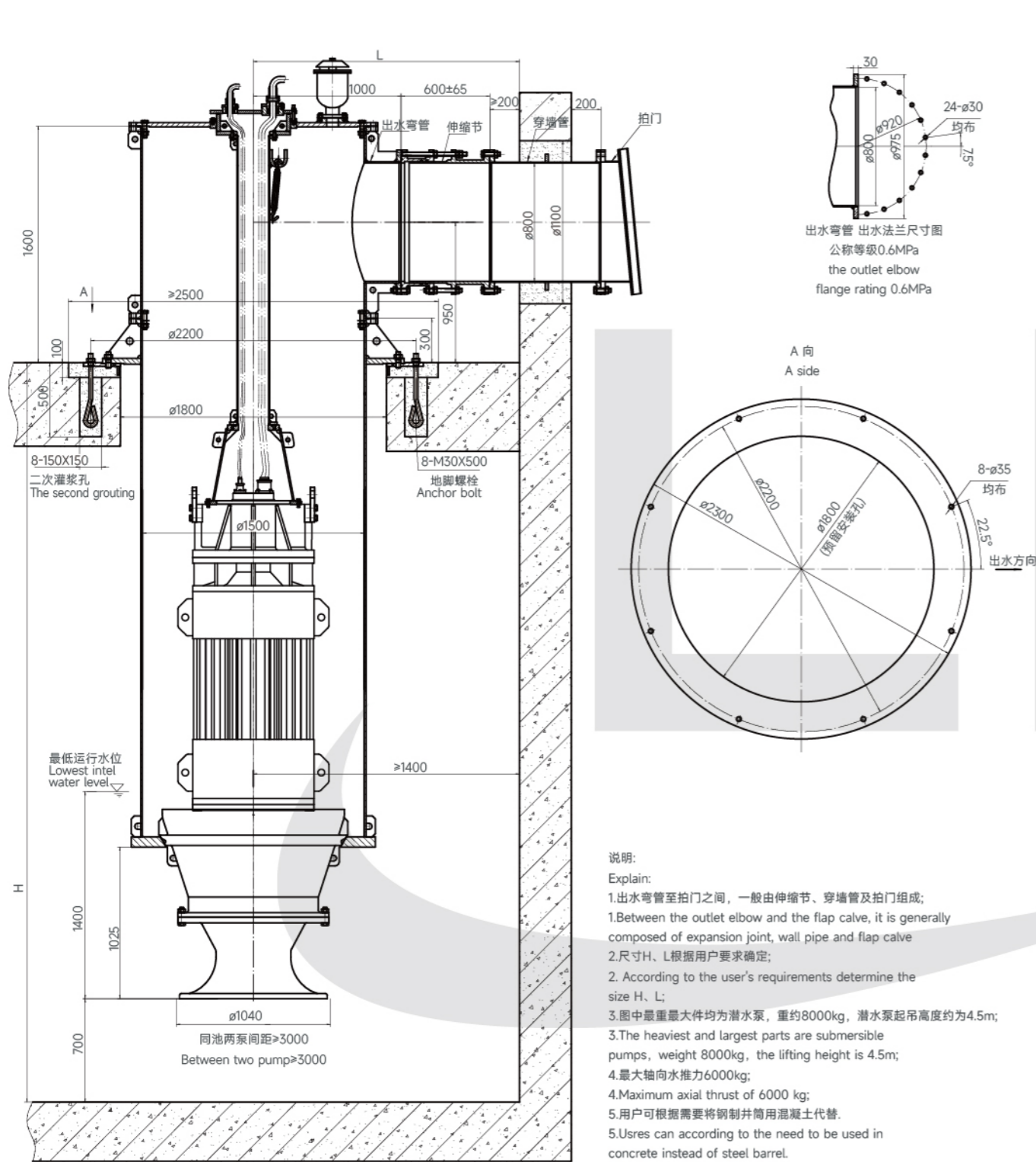

**800QHD-12、14、16、18 型潜水混流泵外形安装图 (DN1200)**

**Erection view for 800QHD-12、14、16、18 submersible Mixed-flow pump (DN1200)**

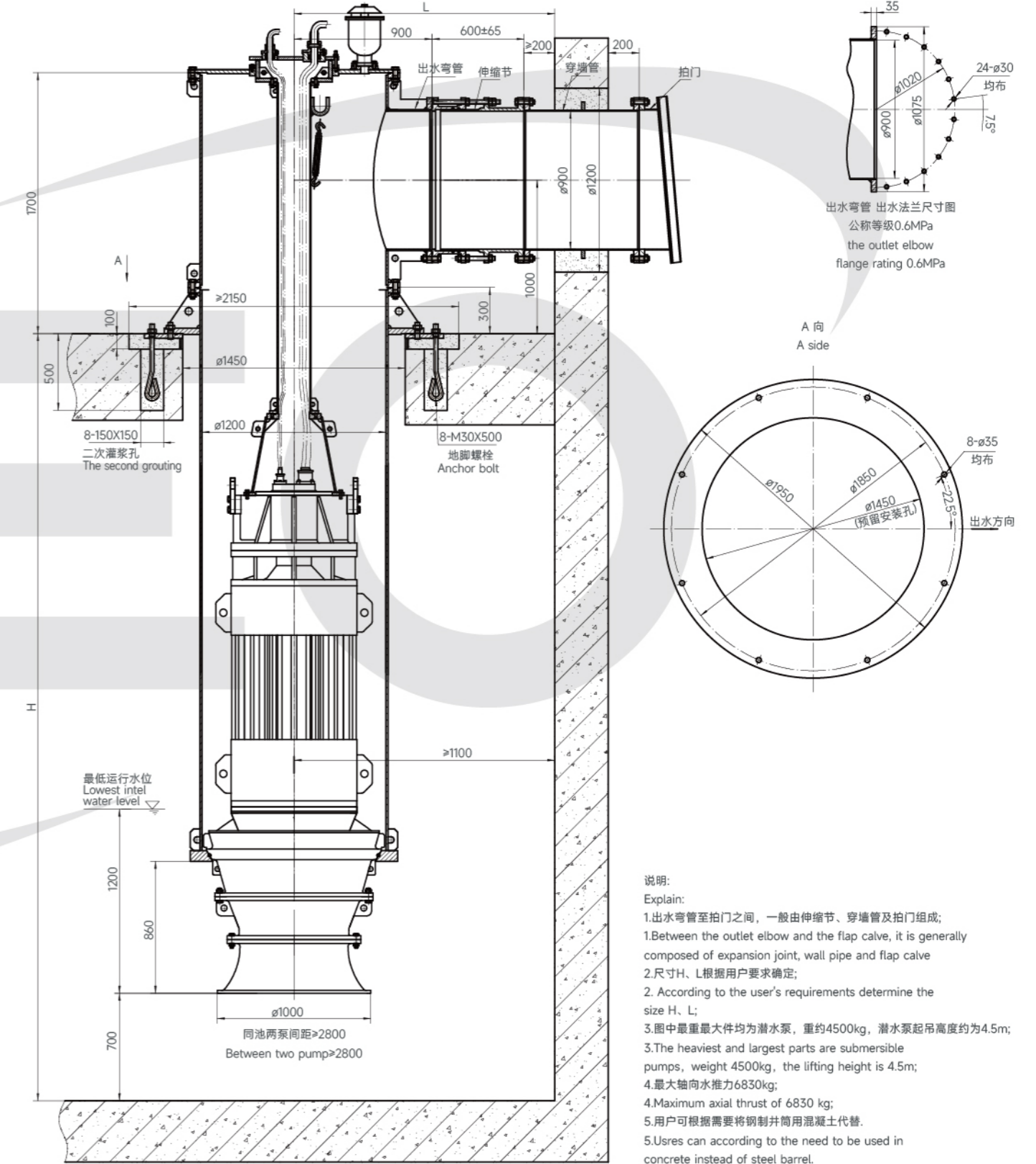

**800QHD-25、28、31、33、35、38 型潜水混流泵外形安装图 (DN1600)**

**Erection view for 800QHD-25、28、31、33、35、38 submersible Mixed-flow pump (DN1600)**

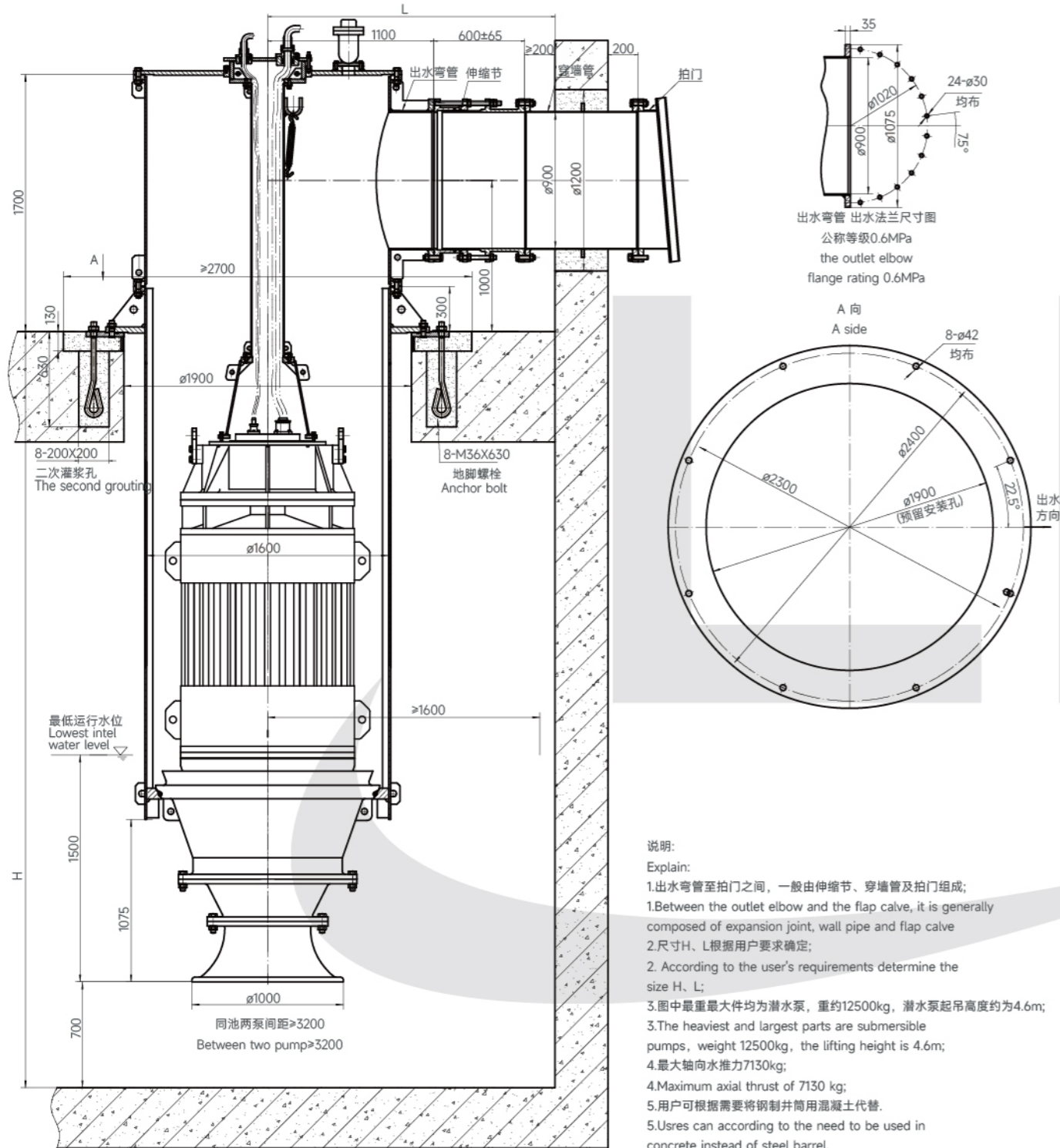

**900QHD-10、11、12、13、14、15 型潜水混流泵外形安装图 (DN1500)**

**Erection view for 900QHD-10、11、12、13、14、15 submersible Mixed-flow pump (DN1500)**

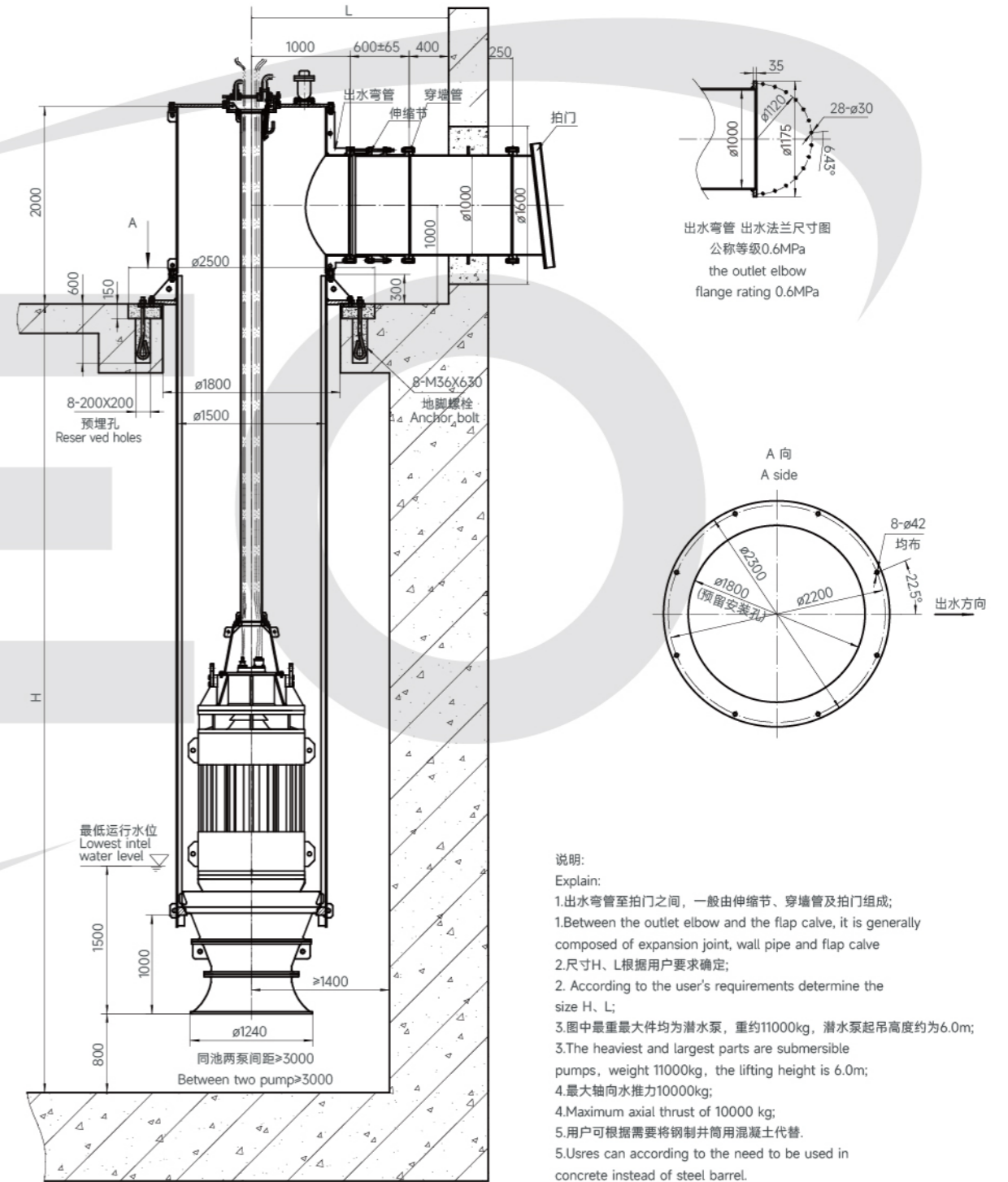

**900QHDX-38、43、48 型潜水混流泵外形安装图 (DN1700)**

**Erection view for 900QHDX-38、43、48 submersible Mixed-flow pump (DN1700)**

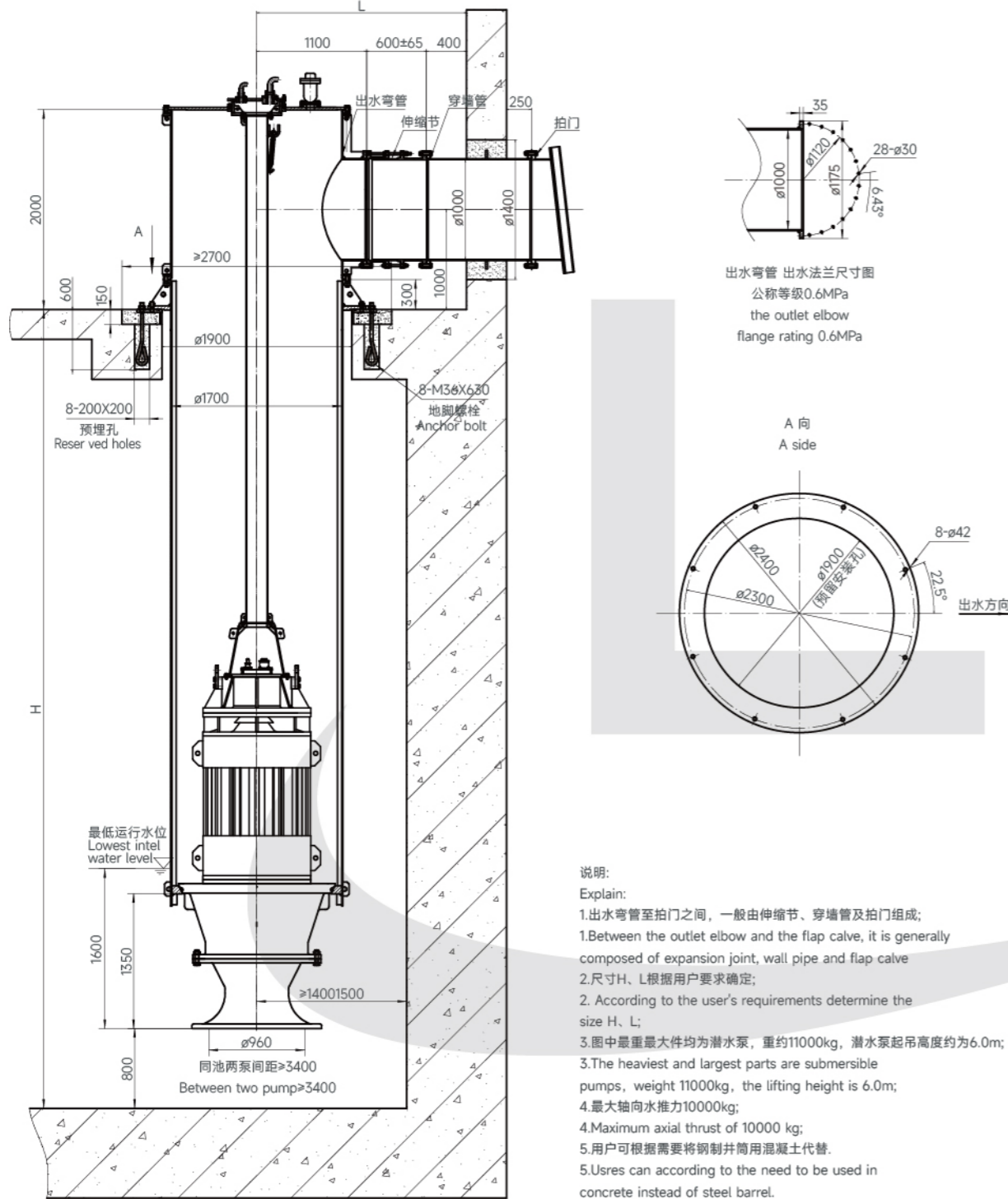

**1000QHD-8、9、10 型潜水混流泵外形安装图 (DN1500)**

**Erection view for 1000QHD-8、9、10 submersible Mixed-flow pump (DN1500)**

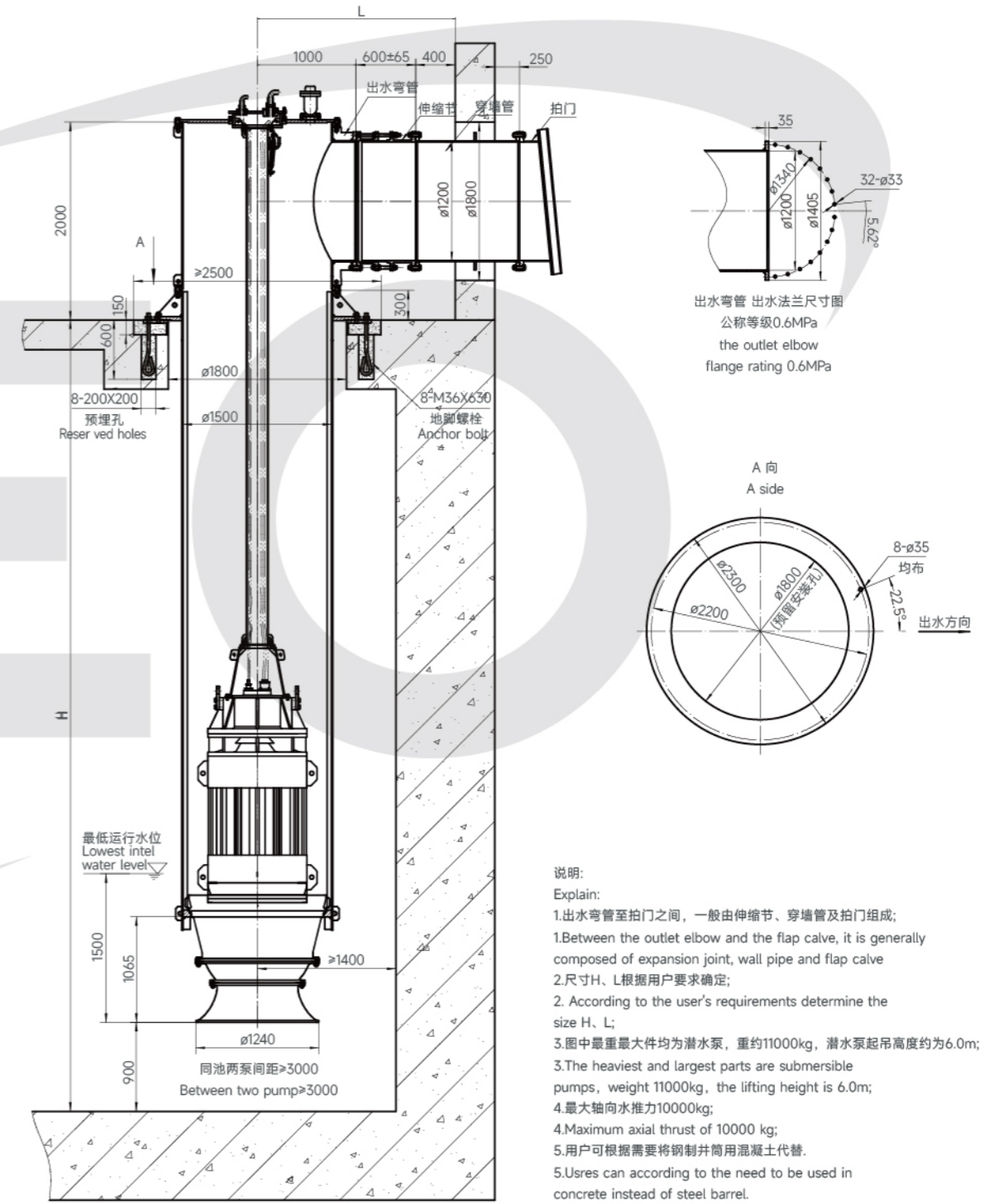

**1000QHD-14、15 型潜水混流泵外形安装图 (DN1600)**

**Erection view for 1000QHD-14、15 submersible Mixed-flow pump (DN1600)**

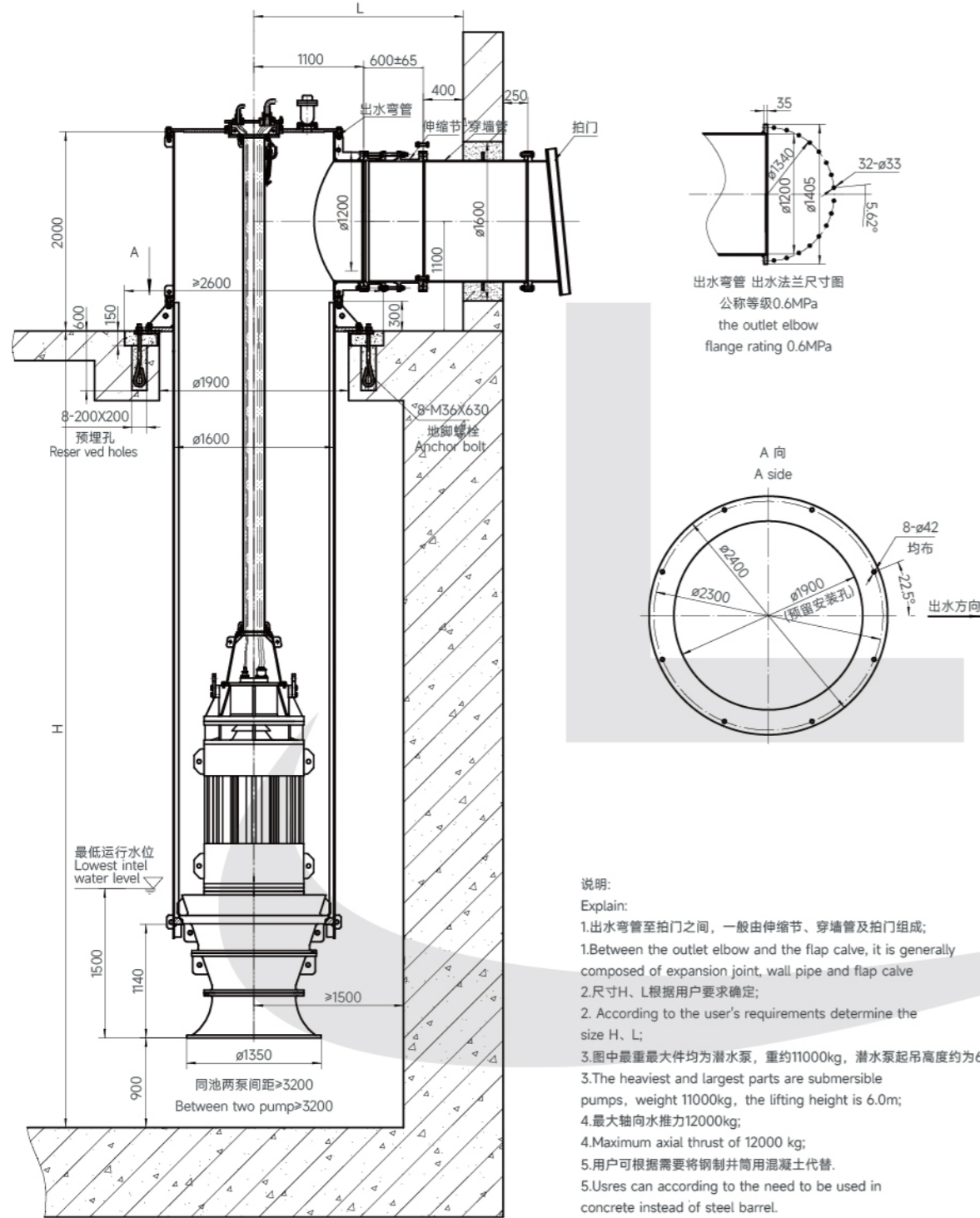

**1000QHD-20、22、1000QHDX-26、29、35、39 型潜水混流泵外形安装图 (DN1700)**

**Erection view for 1000QHD-20、22、1000QHDX-26、29、35、39 submersible Mixed-flow pump (DN1700)**

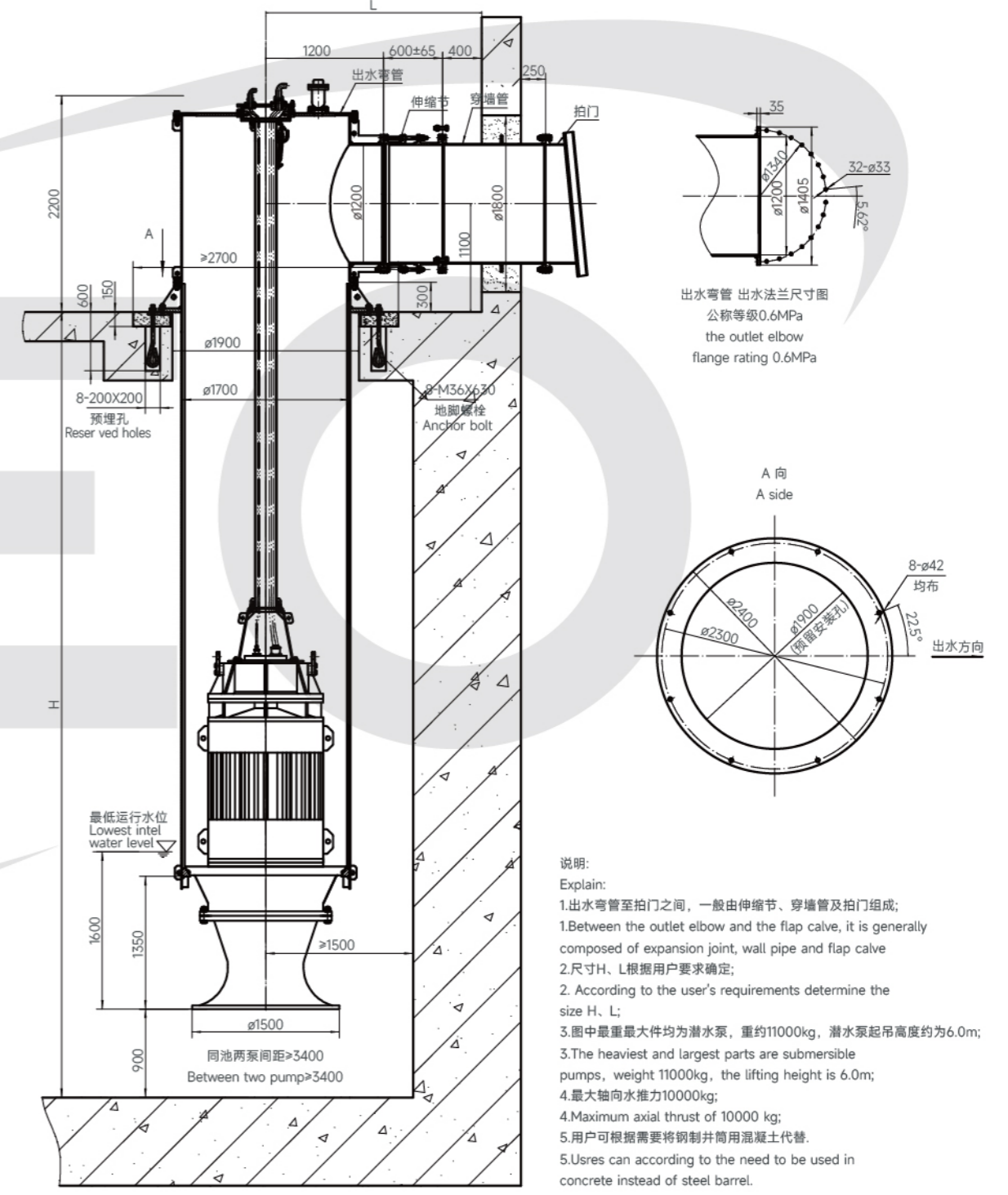

**1200QHD-8.5、10、11、12 型潜水混流泵外形安装图 (DN1900)**

**Erection view for 1200QHD-8.5、10、11、12 submersible Mixed-flow pump (DN1900)**

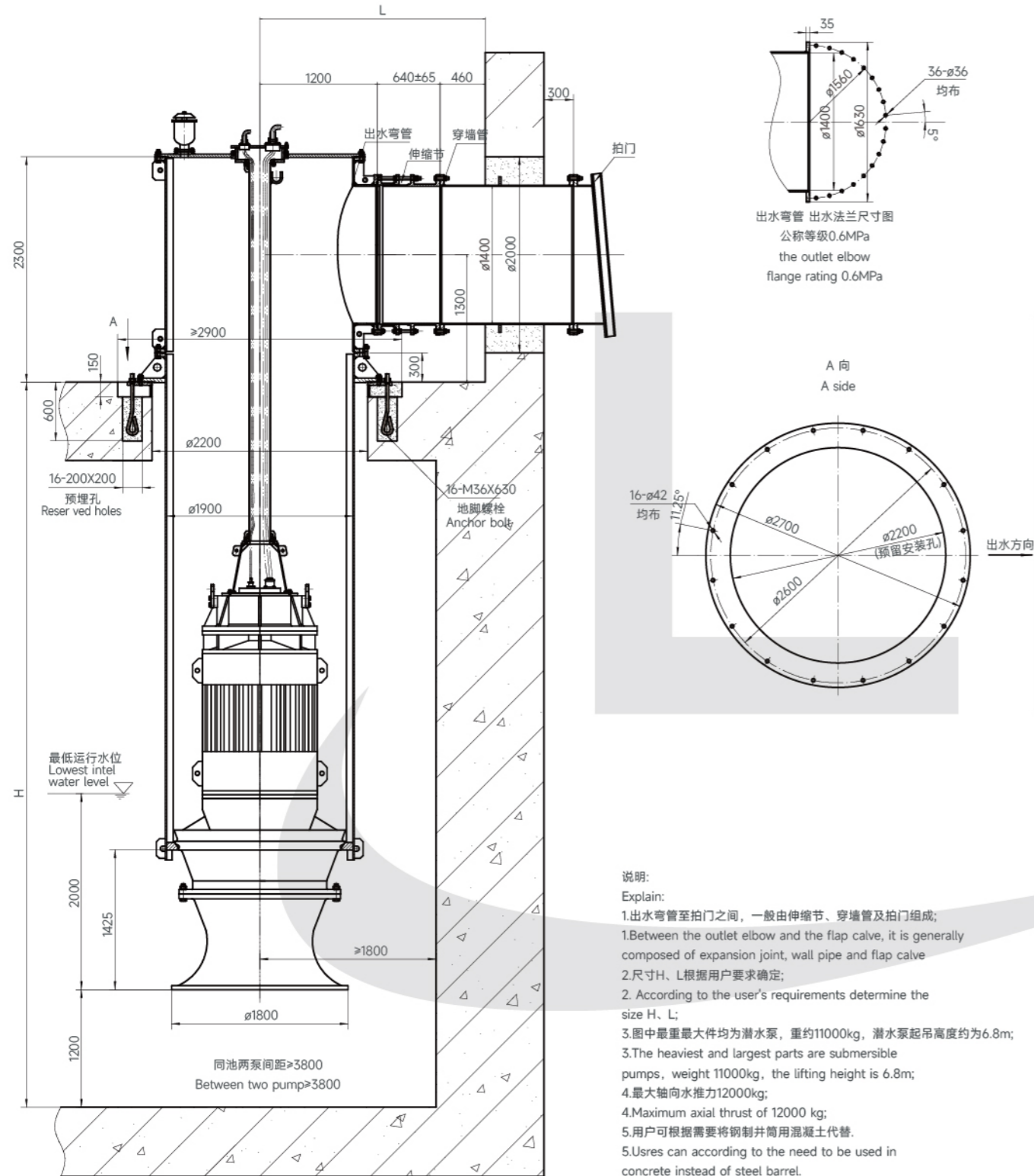

**1200QHDX-19、21、22、28、30 型潜水混流泵外形安装图 (DN2000)**

**Erection view for 1200QHDX-19、21、22、28、30 submersible Mixed-flow pump (DN2000)**

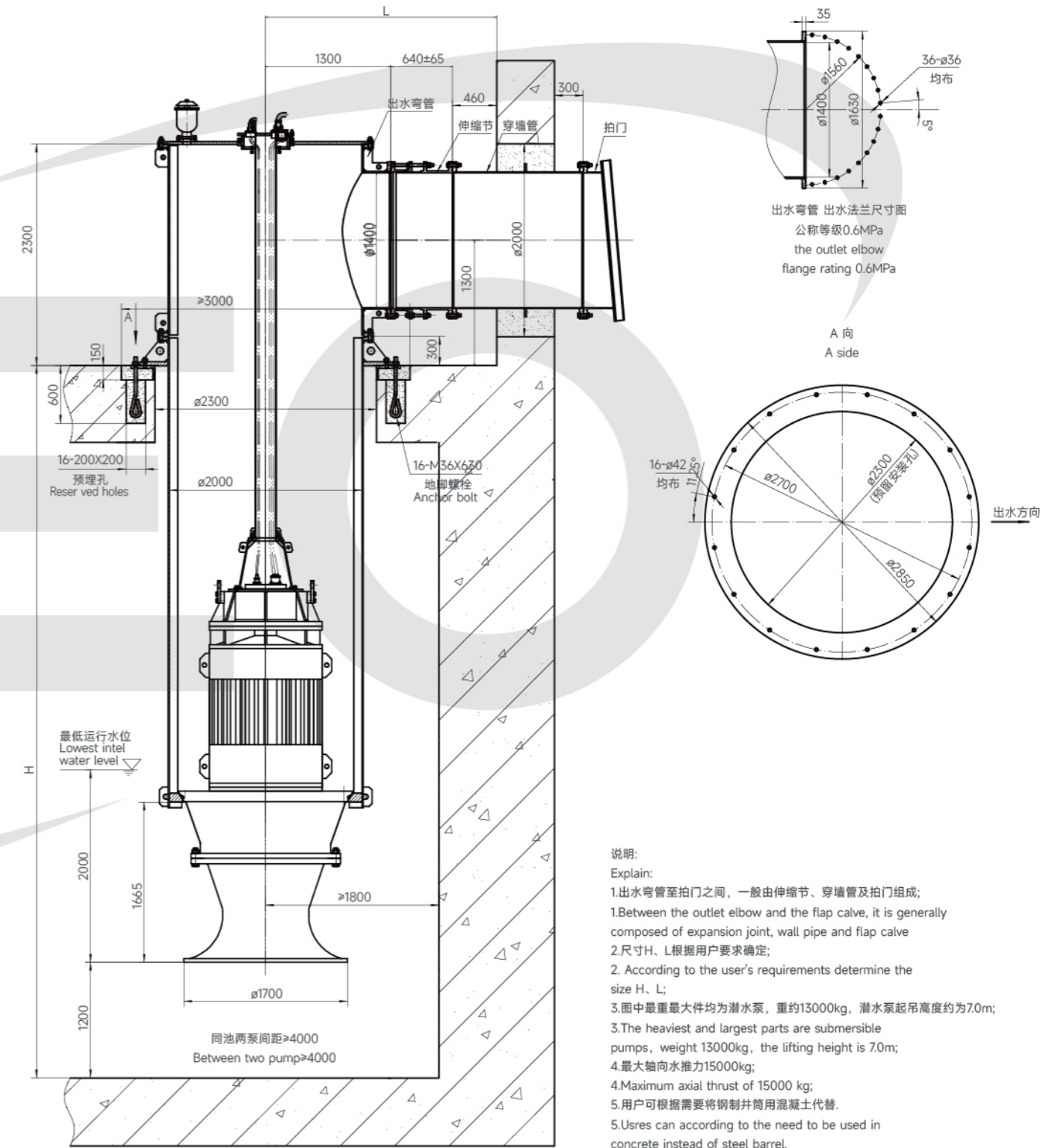

**1400QHDX-12.5、13、14、15、16 型潜水混流泵外形安装图 (DN2000)**

**Erection view for 1400QHDX-12.5、13、14、15、16 submersible Mixed-flow pump (DN2000)**

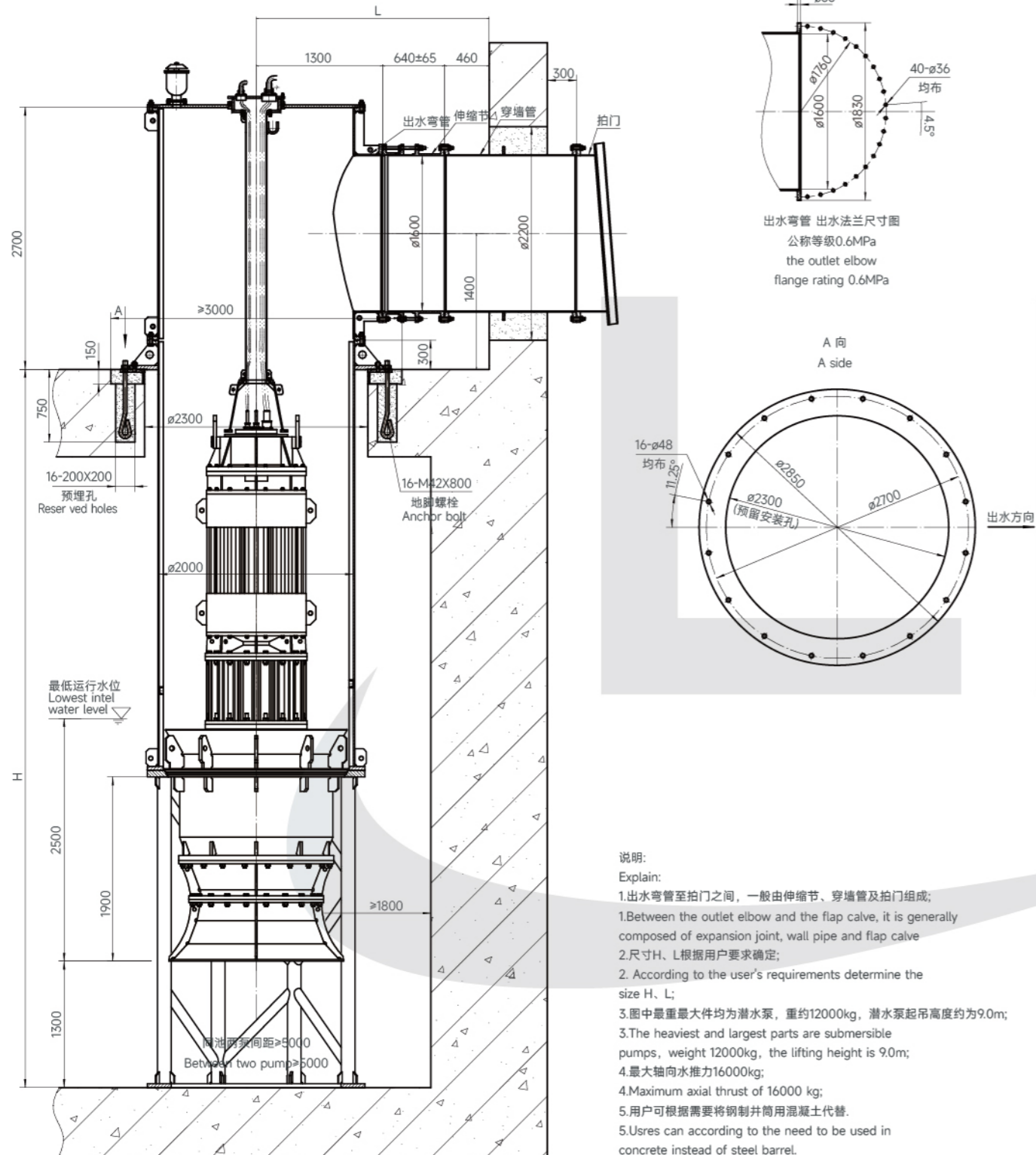

**1400QHDX-18、20、22 型潜水混流泵外形安装图 (DN2100)**

**Erection view for 1400QHDX-18、20、22 submersible Mixed-flow pump (DN2100)**

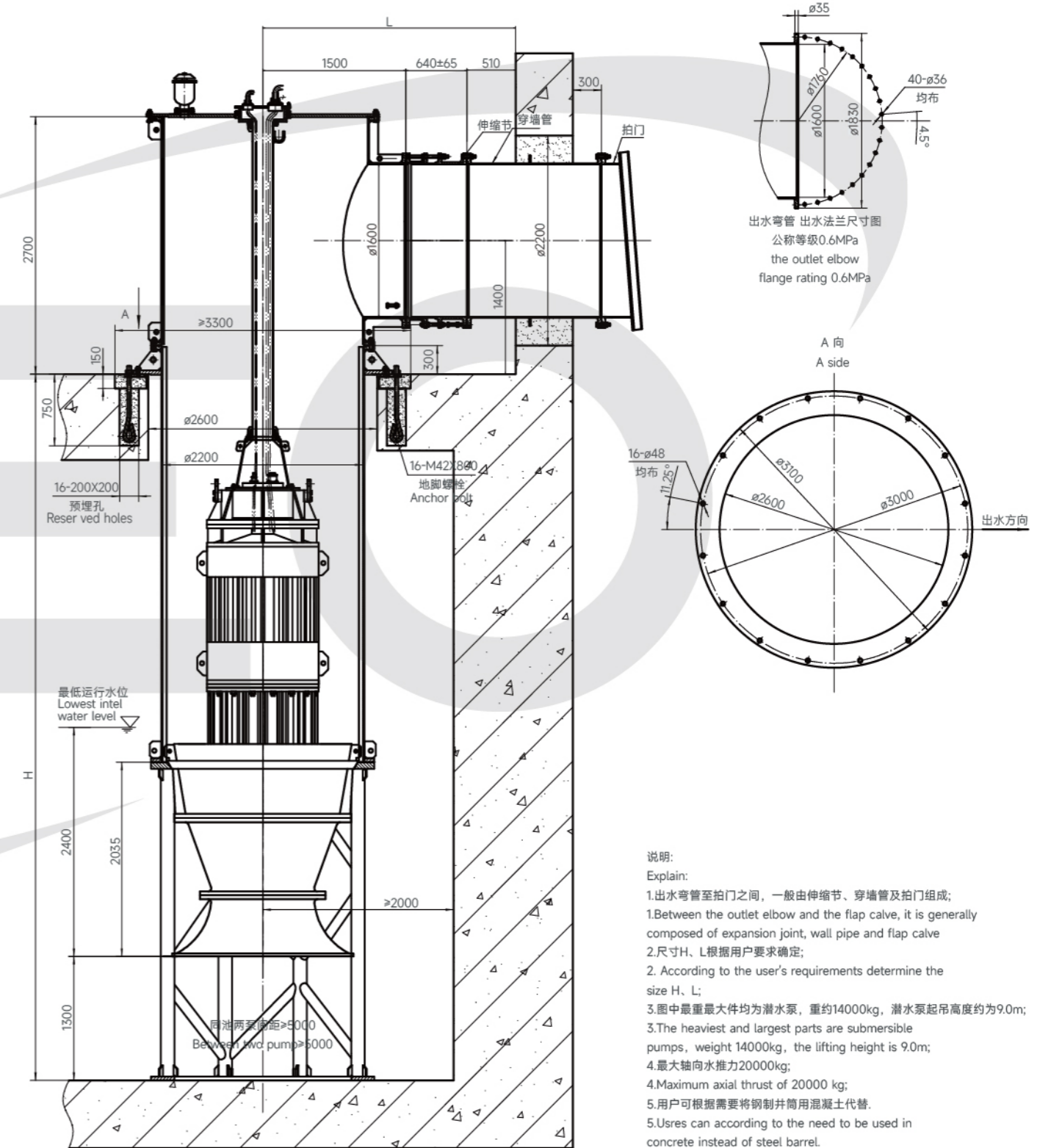

**1600QHDX-9、10、11、12、13、14 型潜水混流泵外形安装图 (DN2300)**

**Erection view for 1600QHDX-9、10、11、12、13、14 submersible Mixed-flow pump (DN2300)**

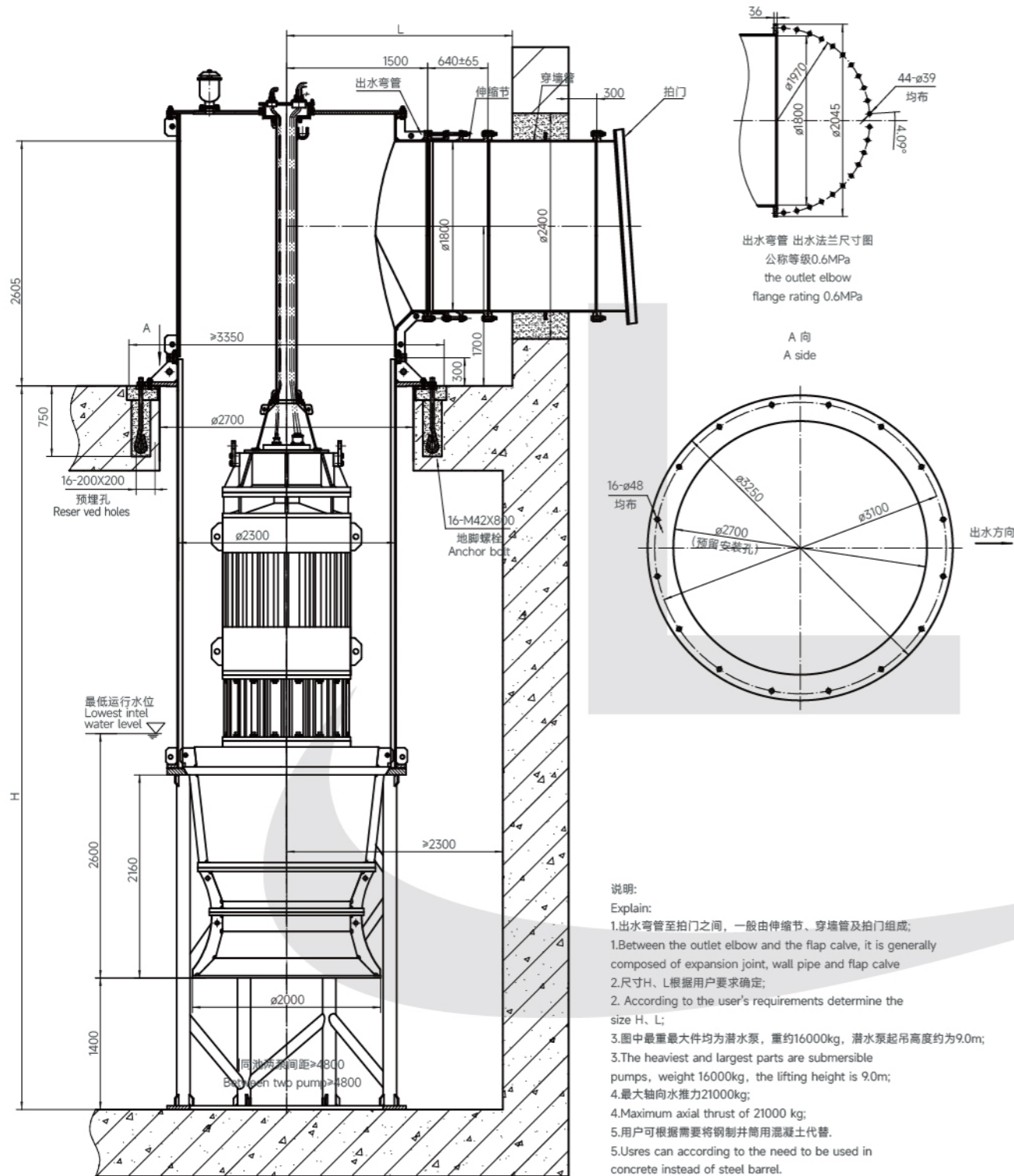

**1600QHDX-9、10、11、12、13、14 型潜水混流泵外形安装图 (流道进水)**

**Erection view for 1600QHDX-9、10、11、12、13、14 submersible Mixed-flow pump (Corridor influent)**

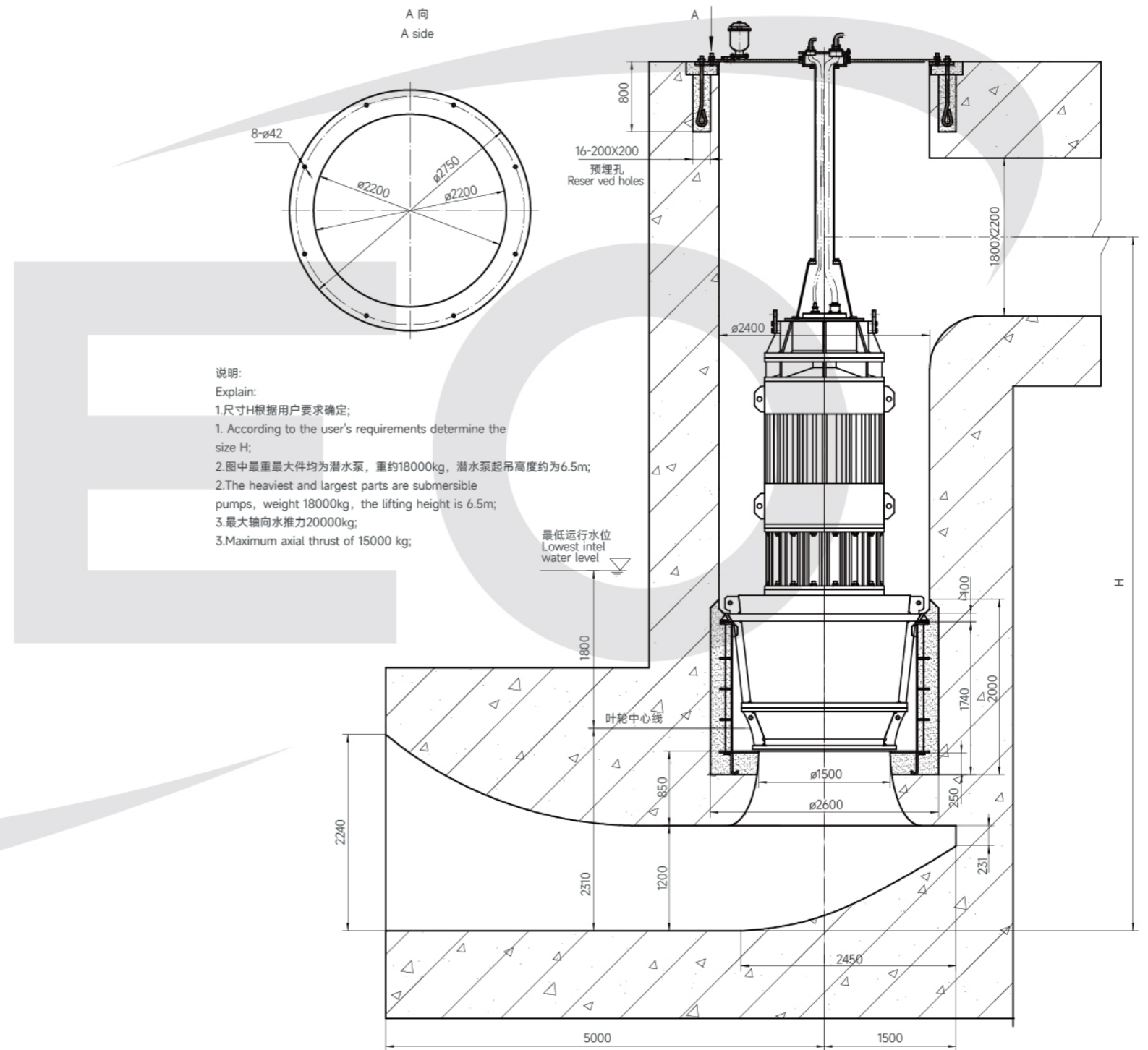

浮箱拍门尺寸表

Size table for floating box flap door

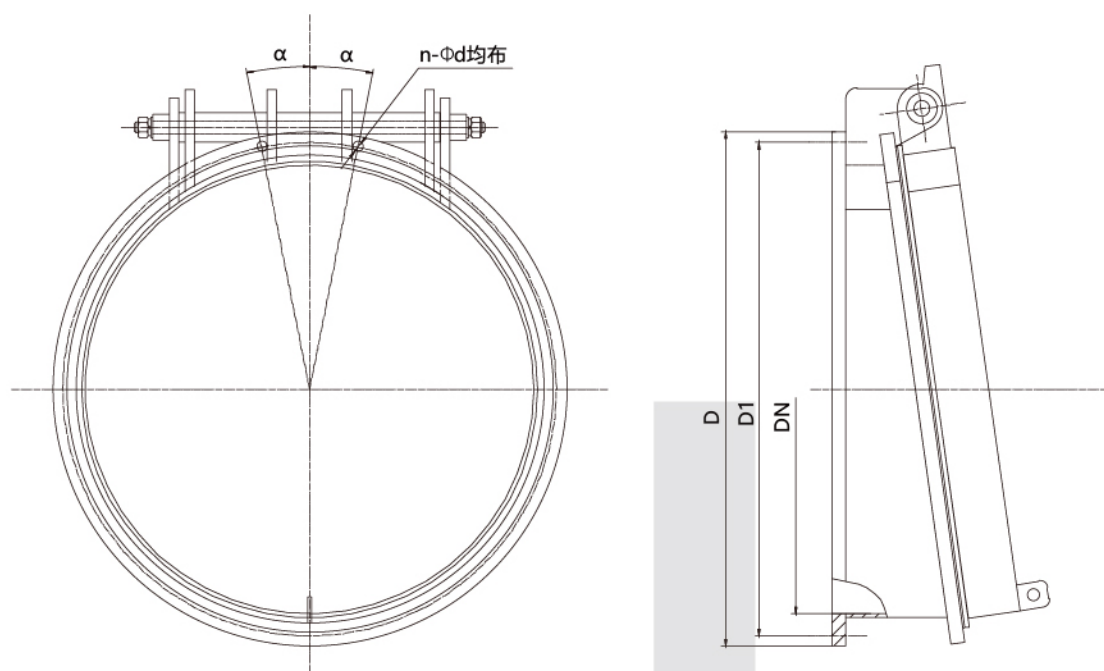

安装说明: 安装时注意拍门中心(上下之垂线)与基面垂直, 以确保拍门启闭顺畅无卡阻。

Installation instruction: Pay attention to the center (vertical line up and down) of the shooting door perpendicular to the base surface during installation to ensure that the opening and closing of the shooting door is smooth and free of jams.

公称通径 (DN)	外径 D	螺孔中心 D1	α	n-φd
φ300	φ440	φ395	30°	6-φ23
φ350	φ485	φ445	30°	6-φ23
φ400	φ535	φ495	22.5°	8-φ23
φ500	φ640	φ600	22.5°	8-φ23
φ550	φ700	φ655	22.5°	8-φ23
φ600	φ755	φ705	18°	10-φ25
φ700	φ860	φ810	15°	12-φ25
φ800	φ975	φ920	15°	12-φ30
φ900	φ1075	φ1020	15°	12-φ30
φ1000	φ1175	φ1120	12.875°	14-φ30
φ1200	φ1400	φ1340	11.25°	16-φ34
φ1400	φ1620	φ1560	10°	18-φ34

节能型侧翻式拍门(单开)尺寸表

Energy saving side flip flap door (single opening) size table

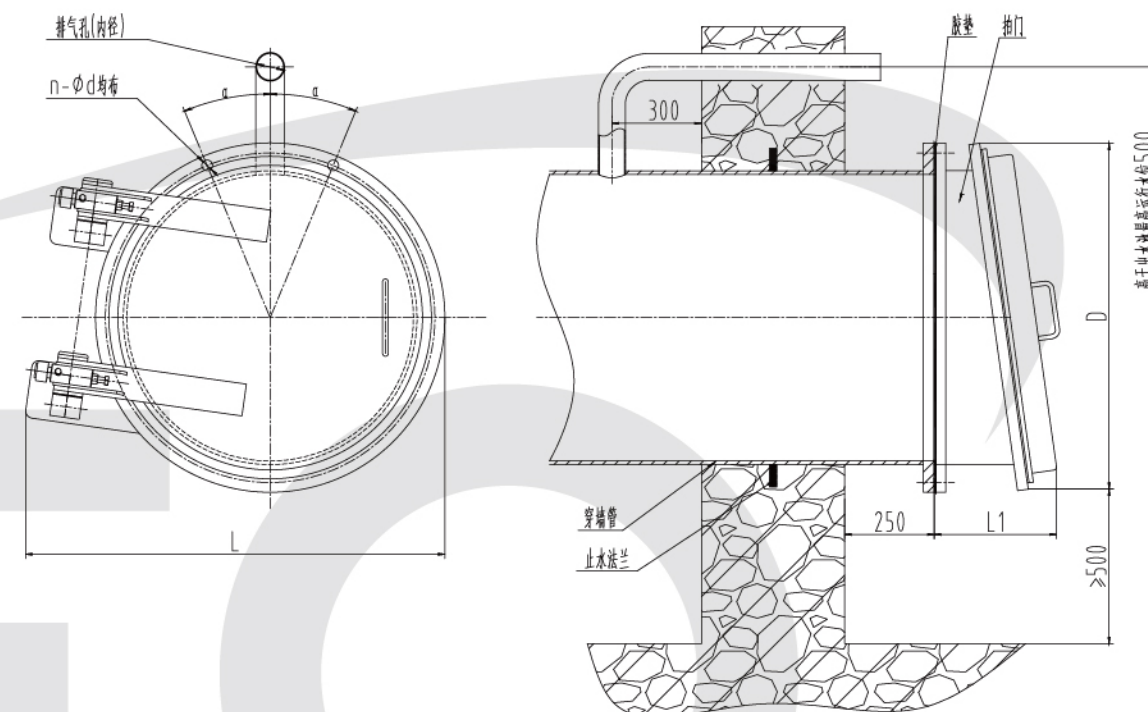

安装说明: 预埋穿墙管时, 务必找准、校对安装中心; 使其(上下之垂线)垂直于基面(满足图示: 2-a 法兰孔所示位置); 以确保拍门安装后, 门盖之分力合理, 启闭灵活。

Installation instruction: When pre-embedded the wall-through pipe, be sure to find out, proofread the installation center so that the vertical line up and down is perpendicular to the base surface (meet the picture: 2-a flange hole location), to ensure that after the door is installed, the force of the door cover is reasonable, and the opening and closing are flexible.

公称通径 (DN)	外径 D	螺孔中心 D1	拍门宽 L	拍门厚 L1	α	n-φd	排气孔内径	拍门重量 (kg)
φ300	φ440	φ395	580	400	30°	6-φ23	φ65	145
φ350	φ485	φ445	630	400	30°	6-φ23	φ65	160
φ400	φ535	φ495	700	400	22.5°	8-φ23	φ65	178
φ500	φ640	φ600	830	420	22.5°	8-φ23	φ65	195
φ550	φ700	φ655	910	430	18°	10-φ23	φ65	235
φ600	φ755	φ705	970	440	18°	10-φ25	φ80	280
φ700	φ860	φ810	1065	450	15°	12-φ25	φ80	300
φ800	φ975	φ920	1195	450	15°	12-φ30	φ100	485
φ900	φ1075	φ1020	1275	460	15°	12-φ30	φ100	590
φ1000	φ1175	φ1120	1380	480	12.875°	14-φ30	φ100	670
φ1100	φ1275	φ1220	1480	480	11.25°	16-φ30	φ100	800

节能型侧翻式拍门（双开）尺寸表

Energy saving side flip flap door (double opening) size table

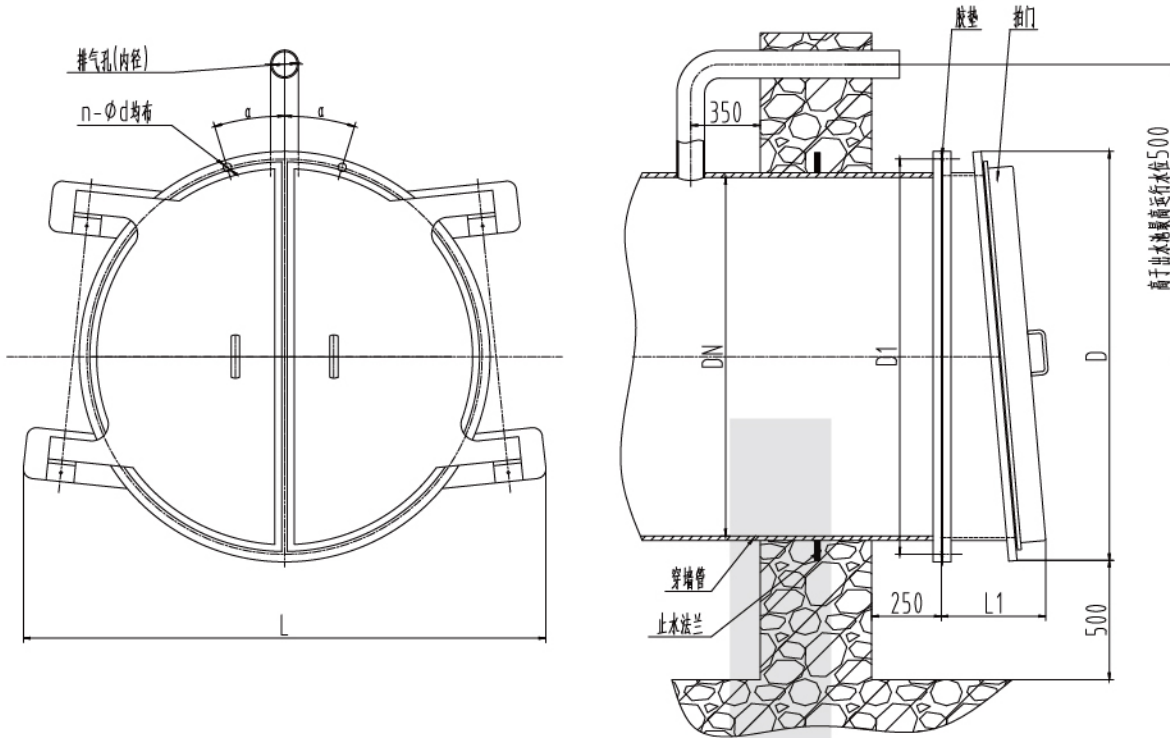

安装说明：1、为减少、修正整个出水管路系统连接法兰螺孔位置的制造误差，以满足本拍门的安装特性，穿墙管末端法兰务必在现场安装，其《安装工艺》有本公司提供。

2、拍门安装后，其中心务必垂直于基面，以确保二门盖分重合理，启闭灵活。

Installation instruction: 1. In order to reduce and correct the manufacturing error of the screw hole position of connecting flange of entire outlet piping system to meet the installation characteristics of this shooting door, the end flange of the wall-through pipe must be installed on site. The installation process is provided by our company.

2. After the door is installed, the center must be perpendicular to base surface to ensure reasonable opening and closing flexibility of the two door covers

公称通径 (DN)	外径 D	螺孔中心 D1	拍门宽 L	拍门厚 L1	α	n-φd	排气孔内径
φ1200	φ1400	φ1340	1750	500	11.25°	16-φ34	φ125
φ1400	φ1620	φ1560	2040	550	10°	18-φ34	φ125
φ1500	φ1720	φ1660	2200	680	10°	18-φ34	φ150
φ1600	φ1820	φ1760	2400	700	9°	20-φ34	φ200
φ1800	φ2045	φ1970	2610	730	8.18°	22-φ41	φ200
φ2000	φ2265	φ2180	2920	780	7.5°	24-φ48	φ300
φ2200	φ2475	φ2390	3220	800	6.923°	26-φ48	φ300
φ2400	φ2685	φ2600	3720	850	6.428°	28-φ48	φ350

公司测试能力 / Test platform of company

占地面积 4169m<sup>2</sup>;

水池容量 15000m<sup>3</sup>, 池深 13.5m。

测量管道并联最大当量直径 2.8m。

最大测试流量 32.78m<sup>3</sup>/s。

最高测试压力 25MPa。

电源装机容量 16000KVA(220V~10KV)。

频率：可针对 5~75Hz 变频可调。

采用高精度检测仪器仪表、传感器和计算机相结合自动测控、采集、处理、分析电力参数及流体参数。

测试中心为《湖南省机械工业流体机械产品质量监督检测站》测试基地之一。

目前为国内领先的水泵综合测试中心之一。

Area: 4169m<sup>2</sup>

Volume of the tank: 15000m<sup>3</sup> ;

Depth: 13.5m.

Maximum lifting weight: 80T; lifting height: 17.5m

Maximum equivalent diameter of parallel pipeline: 2.8m.

Maximum test flow: 32.78 m<sup>3</sup>/s

Maximum test pressure: 25MPa.

Installed power capacity: 16000KVA (220V-10KV)

Frequency: Adjustable frequency 5-75Hz

It can be used to measure and control, collect values, process data, and analyze power parameters and fluid parameters by the combination of high-precision testing instruments, sensors and computers.

The testing center is one of the testing bases of "Hunan Machinery Industry Fluid Machinery Product Quality Supervision and Testing Station"

It is one of the leading comprehensive test centers for water pumps in China currently.



水泵测试中心 / Pump testing centre



企业资质 / Enterprise qualification



**设备选型数据表 / Equipment Selection Data Sheet**

泵型号、参数及配置 PUMP MODEL AND PARAMETER CONFIGURATION			
泵型号 Type		额定流量 Rated flow	m <sup>3</sup> /h
额定扬程 Rated head	m	转速 Speed	r/min
功率 Power	KW	效率 Eff.	%
必需汽蚀余量 NPSHr	m	电压 Voltage	V
附件 Enclosure	<input type="checkbox"/> 出口伸缩节规格 Outlet expansion joint: <input type="checkbox"/> 出口拍门规格 outlet make door: <input type="checkbox"/> 连接件 Connector:		
	<input type="checkbox"/> 综合保护器规格 Integrated protector		
	<input type="checkbox"/> 端子箱型号 Terminal box: <input type="checkbox"/> 电控柜 型号 Electric control cabinet:		
	<input type="checkbox"/> 液位开关 Liquid level switch		
其他 Other			
备注 Remarks	1. 将"□"涂黑表示选定。1.Black"□"to indicate selection.		
	2. 用户工况条件及现场条件由用户填写。2.User's working condition and site conditions shall be filled in by the user		
	3. 泵结构及泵型号、参数、配置由供需双方填写。3.The pump structure,pump model,parameter and configuration shall be filled in by the supplier and the demander.		
泵结构 Pump structure			
是否带齿轮箱 Gear BOX	是 yes <input type="checkbox"/> 不 no <input type="checkbox"/>	轴承品牌 Bearing brand	
电机绝缘等级 Motor insulation class	F <input type="checkbox"/> HO <input type="checkbox"/>	机械密封品牌 Mechanical seal brand	
电机防护等级 Motor protection level	IP68 <input type="checkbox"/> 其他 Other <input type="checkbox"/>	传感器品牌 Sensor brand	
电机温升 Temperature rise of motor	监测 Monitor <input type="checkbox"/> 不监测 Non monitoring <input type="checkbox"/>	轴承温度 Bearing temperature	监测 Monitor <input type="checkbox"/> 不监测 Non monitoring <input type="checkbox"/>
接线室泄漏 Leakage in wiring room	监测 Monitor <input type="checkbox"/> 不监测 Non monitoring <input type="checkbox"/>	电机腔泄漏 Leakage of motor cavity	监测 Monitor <input type="checkbox"/> 不监测 Non monitoring <input type="checkbox"/>
油室泄漏 Oil chamber leakage	监测 Monitor <input type="checkbox"/> 不监测 Non monitoring <input type="checkbox"/>	电缆长度 Cable length	m
主要零件材质 main parts Material	电机机壳 Motor housing	叶轮室 Impeller chamber	导叶体 Guide vane
	叶轮 Impeller	轴 axis	吸入喇叭口 Suction cone
	轮毂体 Wheel body	油室内机械密封 Mechanical seal in oil chamber	油室外机械密封 Oil outdoor mechanical seal
用户工况条件 Operating conditions of users			
介质名称 Medium name		介质特性 properties	腐蚀性 Corrosive <input type="checkbox"/> 磨蚀性 Abrasiveness <input type="checkbox"/> 有毒 Toxic <input type="checkbox"/>
应用工况 Application condition		介质 PH 值 PH value	
介质浓度 Medium concentration	%	介质温度 Medium temperature	°C
介质密度 Medium density	kg/m <sup>3</sup>	气化压力 Vapor Pressure	Mpa(A)( 正常温度 Normal temperature)
介质粘度 Medium viscosity	CP( 正常温度 Normal temperature)	颗粒粒径 Particle size	
固体含量 Solid Content		排出口径 Drainage caliber	
扬程 Head	M	有效汽蚀余量 NPSHa	
运行流量 Running Flow	最小 (MIN) M <sup>3</sup> /H, 正常 (NORMAL) M <sup>3</sup> /H, 最大 (MAX) M <sup>3</sup> /H		
现场条件 Site conditions			
安装方式 Installation mode	钢制井筒安装 (GT)(Steel Barrel installation) <input type="checkbox"/> 钢制井筒落地式安装 (GD)(Steel Barrel Floor mounted installation) <input type="checkbox"/> 水泥井筒安装 (SGT)(Cement Barre installation) <input type="checkbox"/> 其他安装形式:		
安装位置 Installation location	室内 indoor <input type="checkbox"/> 室外 outdoor <input type="checkbox"/>	危险区域 Hazardous area	类级组 Class level group
海拔高度 Altitude	M	环境温度 ambient temperature	°C
池深 Pool depth	M	电源条件 Power condition	V 相 (vphase) Hz

**订货须知 / Product features**

- 必须提供的订货参数：  
泵型号或所需工况点的流量、扬程、需要满足的效率和现场水位标高等参数；  
输送介质的类型、温度、腐蚀性等物理或化学性质；  
零件材料（不注明则按标准配置供货）；  
电机的功率、电压、防护等级、绝缘等级、冷却方式、是否防爆等配置要求；  
其他显示仪表及监测设备要求，如压力表、双金属温度计、PT100 测温电阻，测振装置、压力变送器等；
- 选型说明：  
用户订货不受样本性能参数表中所列参数限制，样本所列参数只是特殊点的性能参数，本公司可根据用户要求设计和制造。
- 有超越样本内容的特殊选型（如 60HZ 运行或变频运行）或对样本有不明之处，请直接向本公司技术中心咨询。
- 特别提醒：  
**本样本安装尺寸保留技术更改的权利，因此，用户在制作基础时，请以本公司技术中心盖章确认的基础尺寸图为准。**
- Please provide the following information when placing an order:  
Pump model or working conditions data: Capacity,Head and Parameters such as efficiency and site water level elevation need to be met;  
Medium: type, temperature, corrosive and other physical or chemical properties;  
Parts material (It not to specify material, pump will be supplied according to standard material);  
Motor requirements: power,voltage.protection class,insulation class, cooling method,anti-xpllosion or not etc.;  
Other display instruments and monitoring equipment requirements, such as pressure gauges, bimetal thermometers, PT100 temperature resistance, vibration measuring devices, pressure transmitters, etc;
- Model Selection Instructions:  
The order is not limited by the performance parameters list. Data in the catalogue is only special point parameters. We can design and manufacture the products according to the requirements of users.
- If you have any queries about special type selection that is beyond content in pump catalogue (for example, deceleration running). please feel free to consult our technical center.
- Special Notice:  
The Company holds the rights to revise the data in the catalogue without any prior warning. Therefore,users have to contact and confirm with our technical center before making the foundation. Dimension drawings shall come into effect with signature or seal.



## 利欧四大产品矩阵

### 家用泵系列

微型旋涡泵		APm XQm
高压自吸泵		APSm LKSm
喷射泵		AJm XKJ
离心泵		ACm
自吸排污泵		XHSm
小型潜水电泵		QDX QDX-L
热水循环泵		ARP LRP
热水管道泵		LPM
泳池泵		XKP
汽油机水泵		LGP
智能家居泵		MTC APSm-AT MAC
不锈钢离心泵		ABK AMS
污水提升器		WC QJ

### 商用泵系列

卧式不锈钢多级离心泵		ECH EDH EMH
立式多级泵		LVR LVS LVSG LVS+LVSD
水处理专用泵		WTR(S) EVP
永磁智能泵		IPM5-R(S) IPM5-LPP IPM5E-EMH
管道泵		LPP LP(m) LP
端吸离心泵		XST XSTP LEZ LEP
不锈钢端吸离心泵		XZS ABK AMS
潜污泵		WQ WQ-N WQ-T
消防产品		XBD-LPP XBD-DL XBD-LVR(S) XBD-XSTP XBD-XST XBD-LEG XBD-CD XBD-DW LEK

### 工业泵系列

立式混流泵		HLB/HLQ
立式轴流泵		ZLB/ZLQ
潜水轴流泵		QZ
高效单级双吸卧式离心泵		GSX
无泄漏立式自吸泵		WLZ/WZY
立式斜流泵		HLBK
筒袋式凝结水泵		GLN
立式长轴泵		GLC
卧式多级离心泵		D/DG
轴向剖分单级卧式离心泵		A
重工位石油化工流程泵		HR
轴向剖分卧式多级离心泵		MA
卧式单壳体多级泵		M
卧式双壳体多级泵		T
透平机组		HTT
轴流泵		HZ
疏水泵		NW
单级悬臂式离心泵		HA/HE

### 智慧水务系列

智慧无负压变频供水系统		BWS-WG
箱式无负压供水系统		BWS-WX
恒压变频供水系统		BWS-HY
永磁全变频无负压供水系统		BWS-WE
集成式智慧泵房		BWS-XZ
智慧一体化预制泵站		LW
柜式集成供水设备		BWS-MS
智慧调蓄无负压加压泵站		BWS-WD
一体化直饮水设备		LZY